



# Product Catalog

## **Packaged Rooftop Air Conditioners Precedent™ — Cooling, Gas/Electric, Heat Pump 5 to 10 Tons — 50 Hz**



March 2015

**RT-PRC039C-EN**





# Introduction

## Packaged Rooftop Air Conditioners

Trane® customers demand products that provide exceptional reliability, meet stringent performance requirements, and are competitively priced. Trane delivers with Precedent™.

Precedent features cutting edge technologies: reliable compressors, Trane engineered ReliaTel™ controls, computer-aided run testing and Integrated Comfort™ Systems. So, whether you're the contractor, the engineer, or the owner, you can be certain Precedent products are built to meet your needs.

Through the years, Trane has designed and developed the most complete line of packaged rooftop products available in the market today. Trane was the first to introduce the micro—microelectronic unit controls—and has continued to improve and revolutionize this design concept.

Electromechanical controls are available for simpler applications, and for the more sophisticated, ReliaTel™ microprocessor controls.

The ReliaTel control platform offers the same great features and functionality as the original micro, with additional benefits for greater application flexibility.

With its sleek, compact cabinet, Precedent continues to provide the highest standards in quality and reliability, comfort, ease of service, and the performance of Trane light commercial products.

## Copyright

This document and the information in it are the property of Trane, and may not be used or reproduced in whole or in part without written permission. Trane reserves the right to revise this publication at any time, and to make changes to its content with obligation to notify any person of such revision or change.

## Trademarks

All trademarks referenced in this document are the trademarks of their respective owners.

## Revision History

RT-PRC039C-EN (15 March 2015)

- General data 6 to 10 ton updates



# Table of Contents

Table of Contents	3
Features and Benefits	4
Standard Features	4
Options	5
Other Benefits	6
Standard Features	6
Variety of Options	9
Other Benefits	12
Application Considerations	14
Selection Procedure—Cooling, Gas/Electric Units	15
Cooling Capacity	15
Heating Capacity	16
Air Delivery Selection	16
Selection Procedure—Heat Pump Units	17
Cooling Capacity	17
Heating Capacity	18
Air Delivery Selection	18
Model Number Descriptions—5 to 10 Tons	19
General Data	20
Performance Data	23
Evaporator Fan Performance	41
Fan Performance	117
Heating Performance Data	124
Controls	132
ReliaTel™ Controlled Units	132
Electrical Data	136
Jobsite Connections	139
Dimensional Data	140
Weights	152
Mechanical Specifications	155



# Features and Benefits

## Standard Features

- 5-year limited compressor warranty
- 5-year limited heat exchanger warranty
- 1-year limited parts warranty
- Anti-short cycle timer
- Colored and numbered wiring
- Convertible airflow
- Crankcase heaters
- Discharge line temperature switch for compressor protection
- Easy access low voltage terminal board (LTB)
- Filters are standard on all units
- Foil-faced and edge captured insulation
- High pressure control
- IAQ dual sloped and removable non-corrosive drain pans
- Liquid line refrigerant drier
- Low ambient cooling to 0°F
- Low pressure control
- Operating charge of R-410A
- Patent-pending hybrid condenser coil for easy cleaning
- Phase monitor
- Progressive tubular aluminized steel heat exchanger
- Provisions for through-the-base condensate drain connections
- Quick access panels
- Quick adjust fan motor mounting plate
- ReliaTel™ microprocessor controls
- Reversing valve for cooling and heating mode (available only on heat pump models)
- Single point power
- Single side service
- Standardized components
- Thermal expansion valve
- Trane® built scroll compressors

## Options

**Note:** Refer to model number description for option availability.

### **Factory-Installed Options.**

- Black epoxy pre-coated coils
- CompleteCoat™ condenser coil
- Condensate overflow switch
- Froststat™
- Hinged access doors
- Stainless steel drain pan

### **Factory-Installed or Field-Installed Options**

- 2" MERV 8 filters or 2" MERV 13 filters with filter removal tool
- Barometric relief
- Clogged filter/fan failure switch
- Discharge air sensing kit
- Economizer
- LonTalk® communications interface (LCI)
- Oversized motors (optional on T/Y/W090E and T/Y102E)
- Reference or comparative enthalpy
- Tool-less hail guards
- Trane® communications interface (TCI)

### **Field-Installed Options**

- CO<sub>2</sub> sensor
- Dual thermistor remote zone sensor
- Electric heaters
- High static drive
- LP conversion kit
- Manual outside air damper
- Motorized outside air dampers
- Quick adapt curbs
- Quick start kit
- Remote potentiometer
- Roof curb
- Thermostat
- Ventilation override accessory
- Wireless zone sensor
- Zone sensor

## Other Benefits

- Cabinet design ensures water integrity
- Ease of service, installation and maintenance
- Mixed model build enables “fastest in the industry” ship cycle times
- Outstanding airflow distribution
- ReliaTel™ controls
- Unmatched product support is one of our finest assets. Trane® sales representatives are a support group that can assist you with:
  - Product
  - Application
  - Service
  - Training
  - Special applications
  - Specifications
  - Computer programs and much more

## Standard Features

### Anti-Short Cycle Timer

Provides a 3-minute minimum ON time and 3-minute OFF time for compressors to enhance compressor reliability by assuring proper oil return.

### Belt Drive Motors (Three-phase)

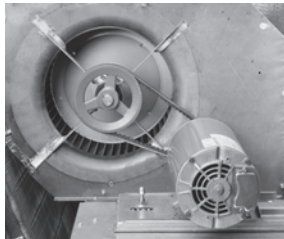

For additional static requirements, Precedent™ three-phase belt drive motors offer capability for a wide range of airflow needs.

### Colored and Numbered Wiring

Save time and money tracing wires and diagnosing the unit.

### Compressors



Precedent contains the best compressor technology available to achieve the highest possible performance. Dual compressors are outstanding for humidity control, light load cooling conditions, and system back-up applications. Dual

compressors are available on 8½ to 10 ton models.

### Condenser Coil



Precedent boasts a patent-pending 1+1+1 condenser coil, permanently gapped for easy cleaning.

### Controls—ReliaTel™

ReliaTel microprocessor controls provide unit control for heating, cooling and ventilating utilizing input from sensors that measure indoor and outdoor temperature and other zone sensors. ReliaTel also provides outputs for building automation systems and expanded diagnostics. For a complete list of ReliaTel offerings, refer to the “Other Benefits” section within the Features and Benefits section of this catalog.

### Convertible Units



The units ship in a downflow configuration. They can be easily converted to horizontal by simply moving two panels.

Units come complete with horizontal duct flanges, so the contractor doesn't have to field fabricate them. These duct flanges are a time and cost saver.

### Crankcase Heaters

These band heaters provide improved compressor reliability by warming the oil to prevent migration during off-cycles or low ambient conditions.

### Discharge Line Temperature Switch

This feature is standard on all units.

### Dual Sloped Drain Pans

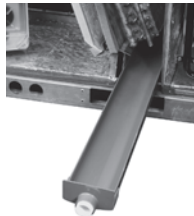

Every Precedent™ unit has a non-corrosive, removable, double-sloped drain pan that is easy to clean and reversible to allow installation of drain trap on either side of the unit.

### Easy Access Low Voltage Terminal Board

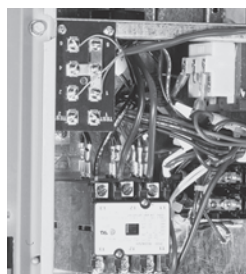

Precedent's Low Voltage Terminal Board is external to the electrical control cabinet. It is extremely easy to locate and attach the thermostat wire and test operation of all unit functions. This is another cost and time saving installation feature.

### Foil Faced Insulation



All panels in the evaporator section of the unit have cleanable foil-faced insulation. All edges are either captured or sealed to ensure no insulation fibers get into the airstream.

### Heat Exchanger

The compact cabinet features a progressive tubular heat exchanger in low, medium and high heat capacities.

The heat exchanger is fabricated using stainless steel burners and corrosion-resistant, aluminized steel tubes as standard on all models. It has an induced draft blower to pull the gas mixture through the burner tubes. The heater has a direct spark ignition system which doubles as a safety device to prove the flame.

## Features and Benefits

---

### **High Pressure Control**

All units include high pressure control as standard.

### **Low Ambient Cooling**

All Precedent™ microprocessor units have cooling capabilities down to 0°F as standard.

### **Low Voltage Connections**

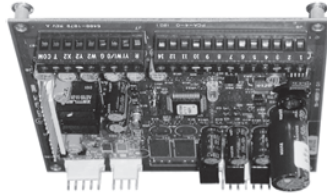

The wiring of the low voltage connections to the unit and the zone sensors is as simple as 1-1, 2-2, and 3-3. This simplified system makes it easy for the installer to wire.

### **Phase Monitoring Protection**

Precedent units with 3-phase power are equipped with phase monitoring protection as standard. These devices protect motors and compressors against problems caused by phase loss, phase imbalance and phase reversal indication.

### **Quick-Access Panels**

Remove two screws for access to the standardized internal components and wiring.

### **Single Point Power**

A single electrical connection powers the unit.

### **Single Side Service**

Single side service is standard on all units.

### **Standardized Components**

Components are placed in the same location on all Precedent units.

Due to standardized components throughout the Precedent line, contractors/owners can stock fewer parts.

### **Thermal Expansion Valve**

This feature is standard on all units.

### **Through-the-Base Condensate**

Every unit includes provisions for through-the-base condensate drain connections. This allows the drain to be connected through the roof curb instead of a roof penetration.



## Variety of Options

### Factory-Installed Options

**Note:** Refer to model number description for option availability.

#### **Black Epoxy Pre-Coated Coils (not available on microchannel condenser coils)**

The pre-coated coils are an economical option for protection in mildly corrosive environments.

#### **CompleteCoat™ Condenser Coil**

These coils provide excellent corrosion resistance as well as uniformity of coverage and coating thickness. This option is available for both fin-tube and microchannel condenser coils.

#### **Condensate Overflow Switch**

A condensate overflow switch is available to shut the unit down in the event that the condensate drain line becomes clogged. This option protects the unit from water overflowing from the drain pan and entering the base of the unit.

#### **Frostat™**

This capillary bulb embedded in the face of the evaporator coil monitors coil temperature to prevent evaporator icing and protect the compressor. Recommended for applications with low leaving air temperatures, low airflow, and or high latent load applications.

#### **Hinged Access Doors**



These doors permit easy access to the filter, fan/heat, and compressor/control sections. They reduce the potential roof damage from screws or sharp access door corners.

#### **Stainless Steel Drain Pan**

For excellent corrosion and oxidation resistance, the optional stainless steel drain pan provides a cleanable surface that compliment other IAQ solutions such high efficiency filtration (MERV 8 or 13) and demand control ventilation (CO<sub>2</sub>).

### Factory-Installed or Field-Installed Options

**Note:** Refer to model number description for option availability.

#### **Barometric Relief**

Designed to be used on downflow units, barometric relief is an unpowered means of relieving excess building pressure.

#### **Clogged Filter/Fan Failure Switch**

A dedicated differential pressure switch is available to achieve active fan failure indication and/or clogged filter indication.

These sensors allow a zone sensor service light or integrated comfort system to indicate a dirty filter or a fan that's not working. The field installation charges for these valuable feedback devices often eliminate them from consideration. Factory installation can make such features a good investment.

## Features and Benefits

---

### **Discharge Air Sensing Kit**

Provides true discharge air sensing in heating models. The kit is functional only with the ReliaTel™ options module.

### **Fresh Air Options—Dampers and Economizer**

0 to 25% manual or 0 to 50% motorized outside air hoods are available.

Economizers are equipped with either dry bulb or reference or comparative enthalpy sensing. These economizers provide free cooling as the outdoor temperature and/or humidity decreases. Correctly installed, they offer a valuable energy savings. Factory-installed economizers save time and ensure proper installation.

The economizers come with three control options—dry bulb is standard; enthalpy and differential enthalpy are optional.

### **High Efficiency Filtration**

Precedent™ units offer a variety of high efficiency filtration option. MERV 8 and MERV 13 filters provide additional filtration beyond the capabilities of typical 2" throwaway filters. When MERV 8 or MERV 13 filters are ordered, units come with a filter removal tool.

### **LonTalk® Communications Interface**

The LonTalk communications interface allows the unit to communicate as a Tracer™ LCI-V device or directly with the generic LonTalk network building automation system controls.

### **Oversized Motors**

Factory-installed or field-installed oversized motors available for high static applications.

### **Reference or Comparative Enthalpy**

Measures and communicates humidity while maximizing comfort control.

### **Trane© Communication Interface (TCI)**

Available factory installed or field installed. This module, when applied with the ReliaTel™, easily interfaces with Trane's Integrated Comfort™ System.

### **Tool-less Hail Guards**



Tool-less, hail protection quality coil guards shall be either factory installed or field installed for condenser coil protection. This option protects the condenser coil from vandalism and/or hail damage.

## Field-Installed Options

**Note:** Refer to model number description for option availability.

### **CO<sub>2</sub> Sensor—Demand Control Ventilation (DCV)**

Demand-controlled ventilation (DCV) is a control strategy that responds to the actual demand (need) for ventilation by regulating the rate at which the HVAC system brings outdoor air into the building. A CO<sub>2</sub> sensor measures the concentration (parts per million, ppm) of CO<sub>2</sub> (carbon dioxide) in the air. As the CO<sub>2</sub> concentration changes, the outside air damper modulates to meet the current ventilation needs of the zone. The CO<sub>2</sub> sensor kit is available as a field installed accessory.

### **Dual Thermistor Remote Zone Sensor**

This sensor will reduce the total number of remote sensors to obtain space temperature averaging. This sensor should be utilized with ReliaTel™ controls.

### **Electric Heaters**

Electric heat modules are available within the basic unit.

### **High Static Drive**

Available on many models, this high static drive accessory extends the capability of the standard motor. Avoid expensive motors and operating costs by installing this optimized sheave accessory.

### **LP Conversion Kit**

Provided for field conversion of gas/electric units from natural gas to propane.

### **Quick Adapt Curbs**

Enables easy conversion of existing Voyager 3 to 10 ton units to Precedent™ units on replacement jobs.

### **Roof Curbs**

Available for downflow units. Only three roof curbs for the entire line simplifies curb selection.

### **Remote Potentiometer**

When properly installed in the economizer control circuitry, this accessory provides a remote variable resistance to enable the operator to adjust the minimum damper position.

### **Ventilation Override Accessory**

With the ventilation override accessory installed, the unit can be set to transition to up to three different pre-programmed sequences for smoke purge, pressurization, and exhaust. The transition occurs when a binary input on the RTOM is closed (shorted). This typically would be a hard-wired relay output from a smoke detector or fire control panel. The ventilation override kit is available as a field-installed accessory.

### **Zone Sensors/Thermostats**

Available in programmable, automatic and manual styles.

## Other Benefits

### **Easy to Install, Service, and Maintain**

Because today's owners are very cost conscious when it comes to service and maintenance, the Precedent™ was designed with direct input from service contractors. This valuable information helped to design a product that would get the service person off the job quicker and save the owner money. Precedent offers outstanding standard features enhanced by a variety of factory and field installed options, multiple control options, rigorously tested proven designs and superior product and technical support.

### **Airflow Distribution**

Airflow is outstanding. Precedent can replace an older machine with old ductwork and, in many cases, improve the comfort through better air distribution.

### **Cabinet Integrity**



For added water integrity, Precedent has a raised 1 1/8" lip around the supply and return of the downflow units to prevent water from blowing into the ductwork.

### **Flexibility**

Precedent offers ultimate flexibility. Units are built to order in our standard "shortest in the industry" ship cycle time.

### **ReliaTel™ Controls**

ReliaTel controls provide unit control for heating, cooling and ventilating utilizing input from sensors that measure outdoor and indoor temperature.

ReliaTel control logic enhances quality and reliability:

- Prevents the unit from short cycling, considerably improving compressor life.
- Ensures that the compressor will run for a specific amount of time which allows oil to return for better lubrication, enhancing the reliability of the compressor.

Precedent units with ReliaTel reduces the number of components required to operate the unit, thereby reducing possibilities for component failure.

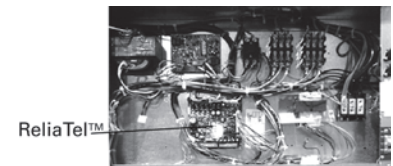
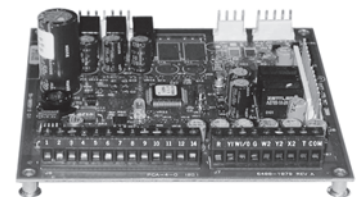

### **ReliaTel Makes Installing and Servicing Easy**

ReliaTel eliminates the need for field installed anti-short cycle timer and time delay relays. ReliaTel controls provide these functions as an integral part of the unit. The contractor no longer has to purchase these controls as options and pay to install them.

The wiring of the low voltage connections to the unit and the zone sensors is as easy as 1-1, 2-2, and 3-3. This simplified system makes wiring easier for the installer.

### **ReliaTel Makes Testing Easy**

ReliaTel requires no special tools to run the Precedent unit through its paces. Simply place a jumper between Test 1 and Test 2 terminals on the low voltage terminal board and the unit will walk through its operational steps automatically.

The unit automatically returns control to the zone sensor after stepping through the test mode a single time, even if the jumper is left on the unit.

As long as the unit has power and the “system on” LED is lit, ReliaTel™ is operational. The light indicates that the controls are functioning properly.

ReliaTel features expanded diagnostic capabilities when utilized with Trane® Integrated Comfort™ Systems.

Some zone sensor options have central control panel lights which indicate the mode the unit is in and possible diagnostic information (dirty filters for example).

### **Other ReliaTel Benefits**

The ReliaTel built-in anti-short cycle timer, time delay relay and minimum “on” time control functions are factory tested to assure proper operation.

ReliaTel softens electrical “spikes” by staging on fans, compressors and heaters.

Intelligent fallback is a benefit to the building occupant. If a component fails, the unit will continue to operate at predetermined temperature setpoint.

Intelligent anticipation is a standard ReliaTel feature. It functions continuously as ReliaTel and zone sensor(s) work together in harmony to provide much tighter comfort control than conventional electro-mechanical thermostats.

The same ReliaTel board fits all packaged gas/electric and cooling with electric heat models. This provides standardization of parts for contractors. Less money is tied up in inventory with ReliaTel.

### **Unit Cabinet**

The compact cabinet with rounded corners takes up less room. The beveled and ribbed top aesthetically pleasing and designed to prevent water from pooling.

### **VariTrac® – Building Automation System**

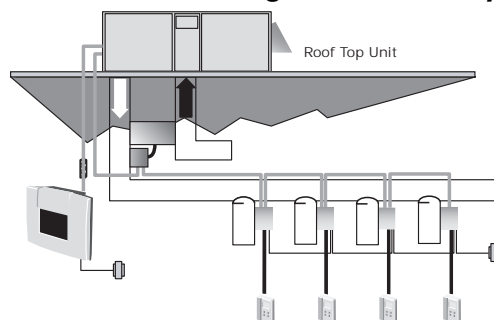

When Trane’s changeover VAV system for light commercial applications is coupled with Precedent™, it provides the latest in technological advances for comfort management systems and can allow thermostat control in every zone served by VariTrac®.

### **Rigorous Testing**

All of Precedent’s designs were rigorously rain tested at the factory to ensure water integrity.

Actual shipping tests were performed to determine packaging requirements. Units were test shipped around the country to determine the best packaging design. Factory shake and drop tests were used as part of the package design process to help assure that the unit arrives at the job site in top condition.

Rigging tests include lifting a unit into the air and letting it drop one foot, assuring that the lifting lugs and rails hold up under stress.

We perform a 100% coil leak test at the factory. The evaporator and condenser coils are leak tested to 3206 kPa (465 psig). The assembled unit is leak tested to 4137 kPa (600 psig).

All parts are inspected at the point of final assembly. Sub-standard parts are identified and rejected immediately.

Every unit receives a 100% unit run test before leaving the production line to make sure it meets rigorous Trane requirements.



## Application Considerations

Application of this product should be within the cataloged airflow and cooling considerations.

### Barometric Relief

This product line offers an optional barometric relief damper for use in conjunction with economizer option. This accessory consists of gravity dampers which open with increased pressure. As the building air pressure increases, the pressure in the unit return air section also increases, opening the dampers and relieving the conditioned space.

**Note:** *The effectiveness of barometric relief damper during economizing operation is system related. Pressure drop of the return air system should be considered to control building pressurization.*

### Black Epoxy Coil

The coils are manufactured with a thermoset vinyl coating that is bonded to the aluminum fin stock prior to the fin stamping process. These coils are an economical option for protection in mildly corrosive environments.

**Note:** *Not to be used where seacoast applications exist.*

### Clearance Requirements

The recommended clearances identified with unit dimensions should be maintained to assure adequate service maximum capacity and peak operating efficiency. Actual clearances which appear inadequate should be reviewed with the local Trane® sales personnel.

### CompleteCoat™ Condenser Coil

The coils provide protection from corrosive environments and are ideal for seacoast applications.

### Condensate Trap

The evaporator is a draw-through configuration. A trap must be field provided prior to start-up on the cooling cycle.

### Heating Operation (Gas/Electric Models Only)

The heat exchanger is manufactured with aluminized steel. To prevent condensation within the heat exchanger, do not exceed 50% outside air or a minimum mixed air temperature of 40°F.

### Low Ambient Cooling

The Precedent™ line features, with ReliaTel™ microprocessor controls, low ambient cooling down to 0°F. The following features or options need to be included/considered when low ambient applications are required: continuous fan operation, crankcase heaters, thermal expansion valves, frostat.

Contact a local Trane representative for more assistance with low ambient cooling applications.

### Unit Pitch

These units have reversible sloped condensate drain pans. Units must be installed level. Any unit slope must be toward the side of unit where condensate drain is connected.



# Selection Procedure—Cooling, Gas/Electric Units

## Cooling Capacity

**Note:** Cooling capacity procedure is the same for electric heat (T\*C) and gas heat (Y\*C).

### Step 1

Calculate the building’s total and sensible cooling loads at design conditions. Use the Trane® calculation methods or any other standard accepted method.

Factors used in unit selection:

- Packaged cooling with optional electric heat
- Total cooling load: 17.3 kW/59 MBh
- Sensible cooling load: 11.7 kW/40 MBh
- Airflow: 3400 m<sup>3</sup>/h/2000 cfm
- Electrical characteristics: 380-415/50/3
- Summer design conditions: entering evaporator coil: 27°C/80°F DB/19°C/60°F WB
- Outdoor ambient: 35°C/95°F
- External static pressure: 90 Pa/0.36 in. wg
- Downflow configuration
- EER: 10.4 COP: 3.1
- Economizer

### Step 2

As a starting point, a rough determination must be made of the size of the unit. The final selection will be made after examining the performance at the given conditions. Divide the total cooling load by nominal kW per ton (3.517 kW per ton) or Btuh per ton (12 MBh per ton); then round up to the nearest unit size.

$$17.3 \text{ kW} / 3.517 = \text{approx. } 5 \text{ tons}$$

$$59 \text{ MBh} / 12 \text{ MBh} = \text{approx. } 5 \text{ tons}$$

### Step 3

Table 3, p. 23 (Table 4, p. 24) shows that a TSC060ED has a **gross** cooling capacity of 18.17 kW/62 MBh and 13.4 kW/45.72 MBh sensible capacity at 3400 m<sup>3</sup>/h /2000 cfm and 35°C/95°F DB outdoor ambient with 27°C/80°F DB, 19°C/60°F WB air entering the evaporator.

#### To find capacity at intermediate conditions not in the table:

When the design conditions are between two numbers in the capacity table, use interpolation to approximate the capacity.

**Note:** Extrapolation outside of the table conditions is not recommended.

### Step 4

To select the correct unit that meets the building’s requirements, deduct the fan motor heat from the gross cooling capacity. The amount of heat that the fan motor generates is dependent on the effort by the motor—cfm and static pressure. To determine the total unit static pressure:

External static duct system	90 Pa/0.36 wg
Standard filter 2 inches from Table 107, p. 119 (Table 108, p. 119)	15 Pa/0.06 wg
Economizer (100% outside air) (worst case)	45 Pa/0.18 wg
Electric heater size 6 kW (see “Heating Capacity” section to determine heater size)	20 Pa/0.08 wg
Total static pressure	170 Pa/0.68 wg

## Selection Procedure—Cooling, Gas/Electric Units

---

**Note:** The evaporator fan performance, [Table 21, p. 41](#) ([Table 22, p. 42](#)) has deducted the pressure drop for a filter already in the unit. Therefore, the actual total static pressure is:  
 $170 - 15 = 155 \text{ Pa}$   $0.68 - 0.06 = 0.62 \text{ wg}$ .

With 3400 m<sup>3</sup>/h and 155 Pa/2000 cfm and 0.62 wg.

[Table 21, p. 41](#) ([Table 22, p. 42](#)) shows 0.51 kW/0.69 bhp for this unit.

**Note:** Following the table is the formula to calculate Fan Motor Heat

$$1.07 \times \text{fan kW} + 0.25 = \text{kW} / 2.72 \times \text{bhp} + 0.85 = \text{MBh}$$

$$1.07 \times 0.51 + 0.25 = 0.80 \text{ kW} / 2.72 \times 0.69 + 0.85 = 2.73 \text{ MBh}$$

Now subtract the fan motor heat from the gross cooling capacity of the unit:

$$\text{Net Total Cooling Capacity: } 18.17 \text{ kW} - 0.80 = 17.37 \text{ kW} / 62 \text{ MBh} - 2.73 = 59.27 \text{ MBh}$$

$$\text{Net Sensible Cooling Capacity: } 13.4 \text{ kW} - 0.80 = 12.6 \text{ kW} / 45.72 \text{ MBh} - 2.73 = 42.99 \text{ MBh}$$

Subtracting sensible from total capacity to find latent capacity:

$$\text{Net Latent Capacity: } 17.37 - 12.6 = 4.77 \text{ kW} / 59.27 - 42.99 = 16.28 \text{ MBh}$$

### Step 5

Compare resulting capacities to the building load. If the performance will not meet the required load of the building's total or sensible cooling load, try a selection at the next higher size unit.

## Heating Capacity

**Note:** Heating capacity procedure DIFFERS for electric heat (T°C) and gas heat (Y°C) units

### Step 1

Calculate the building heating load using the Trane® calculation form or other standard accepted method.

### Step 2

Size the system heating capacity to match the calculated building heating load. The following are building heating requirements:

- Total heating load of 14.4 kW/50 MBh
- 3400 m<sup>3</sup>/h/2000 cfm

*TSC060EDR units with optional electric heat: 380V/3 phase power supply*

The electric heat accessory capacities are listed in [Table 129, p. 136](#). From the table, there are 3 heating capacities available for the TSC060ED, 7.5 kW/26 MBh, 10.9 kW/38 MBh, and 14.4 kW/50 MBh at 380 V. Referring to [Table 129, p. 136](#), the electric heater selection that will supply 14.4 kW/50 MBh of heat is BAYHTRR423B.

*YSC060EDR units with gas heat: Fuel—natural gas*

For the YSC060ED, two heating capacities available are available: 19.6 kW/67 MBh and 29.3 kW/100 MBh input models shown in [Table 111, p. 121](#). The output capacities of these furnaces are 15.7 kW/54 MBh and 23.4 kW/80 MBh, respectively. The low heat model with 15.7 kW/54 MBh output best matches the building requirements, indicating a YSC060EDRL should be selected.

## Air Delivery Selection

**Note:** Air Delivery procedure is the same for electric heat and gas heat units.

External static pressure drop through the air distribution system has been calculated to be 155 Pa. Use [Table 21, p. 41](#) for a TSC060ED at 3400 m<sup>3</sup>/h and 155 Pa. The belt drive motor will give the desired airflow at a rated kW of 0.51 and 965 rpm.



External static pressure drop through the air distribution system has been calculated to be 0.62 inches of water. Use [Table 22, p. 42](#) for a TSC060ED at 2000 cfm and 0.62 static pressure. The belt drive motor will give the desired airflow at a rated bhp of 0.69 and 965 rpm.

# Selection Procedure—Heat Pump Units

## Cooling Capacity

### Step 1

Calculate the building's total and sensible cooling loads at design conditions. Use the Trane® calculation methods or any other standard accepted method.

Factors used in unit selection:

- Total cooling load: 20.8 kW/71 MBh
- Sensible cooling load: 13.2 kW/45 MBh
- Airflow: 4080 m<sup>3</sup>/h/2400 cfm
- Electrical characteristics: 380-415/50/3
- Summer design conditions: entering evaporator coil: 27C DB, 19C WB (80F DB, 67F WB)
- Outdoor ambient: 35C DB (95F DB)
- External static pressure: 114.5 Pa (0.46 in.wg)
- Downflow configuration
- Economizer

### Step 2

As a starting point, a rough determination must be made of the size of the unit. The final selection will be made after examining the performance at the given conditions. Divide the total cooling load by nominal BTUH per ton (12 MBh per ton); then round up to the nearest unit size.

$$71 \text{ MBh} / 12 \text{ MBh} = \text{approx. } 6 \text{ tons}$$

### Step 3

[Table 15, p. 35](#) ([Table 16, p. 36](#)) shows that a WSC072ED has a gross cooling capacity of 23.45 kW (80.00 MBh) and 16.94 kW (57.81 MBh) sensible capacity at 4080m<sup>3</sup>/h (2400 cfm) and 35C DB (95F DB) outdoor ambient with 27C DB, 19C WB (80F DB, 67F WB) air entering the evaporator.

*To find capacity at intermediate conditions not in the table:*

When the design conditions are between two numbers that are in the capacity table, interpolation is required to approximate the capacity.

**Note:** *Extrapolation outside of the table conditions is not recommended.*

### Step 4

To select the correct unit that meets the building's requirements, deduct the fan motor heat from the gross cooling capacity. The amount of heat that the fan motor generates is dependent on the effort by the motor—cfm and static pressure. To determine the total unit static pressure:

External static duct system	114.5 Pa (0.46 wg)
Economizer from <a href="#">Table 109, p. 120</a> ( <a href="#">Table 110, p. 120</a> ) (100% outside air)	27.4 Pa (0.11 wg)
Electric heater size 11.3 kW from <a href="#">Table 113, p. 121</a> (see "Heating Capacity" section to determine heater size)	7.5 Pa (0.03 wg)
Total static pressure	149.4 Pa (0.60 wg)
External static duct system	114.5 Pa (0.46 wg)

## Selection Procedure—Heat Pump Units

---

With 4080m<sup>3</sup>/h (2400 cfm) and 149.4 Pa (0.60 wg). [Table 49, p. 69](#) ([Table 50, p. 70](#)) shows .52 kW (.70 bhp) for this unit.

**Note:** *Following the table is a formula to calculate Fan Motor Heat.*

$$1.070 \times \text{Fan kW} + 0.250 = \text{kW} \quad (2.720 \times \text{Fan bhp} + 0.850 = \text{MBh})$$

$$1.070 \times 0.52 \text{ kW} + 0.250 = 0.81 \text{ kW} \quad (2.720 \times 0.70 \text{ bhp} + 0.850 = 2.75 \text{ MBh})$$

Now subtract the fan motor heat from the gross cooling capacity of the unit:

$$\text{Net Total Cooling Capacity: } 23.45 \text{ kW} - 0.81 = 22.64 \text{ kW}/80.0 \text{ MBh} - 2.75 = 77.25 \text{ MBh}$$

$$\text{Net Sensible Cooling Capacity: } 16.94 \text{ kW} - 0.81 = 16.13 \text{ kW}/57.81 \text{ MBh} - 2.75 = 55.06 \text{ MBh}$$

### Step 5

Compare results to original load requirements. If the performance will not meet the required total or sensible cooling load, try a selection at the next higher size unit.

## Heating Capacity

### Step 1

Calculate the building heating load using the Trane calculation form or other standard accepted method.

### Step 2

Size the equipment using [Table 121, p. 126](#) ([Table 122, p. 127](#)) to match the heating loads at design conditions.

- Total heating load of 19.0 kW/65 MBh
- Outdoor Ambient (Winter): -8C DB/17F DB
- Indoor Return Temperature: 21C DB/70F DB
- Airflow: 3400 m<sup>3</sup>/h/2000 cfm

Use the integrated portion of [Table 121, p. 126](#) ([Table 122, p. 127](#)) for the WSC072E to determine capacity at winter design conditions. The mechanical heating portion of the heat pump will provide 12.0 kW/41.15 MBh.

### Step 3

Because 12.0 kW/41.15 kW is less than the building's required heating capacity at winter design conditions, a supplementary heater must be selected.

$$19.0 \text{ kW} - 12.0 \text{ kW} = 7.0 \text{ kW}/65 \text{ MBh} - 41.15 \text{ MBh} = 23.85 \text{ MBh}$$

From [Table 130, p. 137](#), the BAYHTRS418B heater will deliver 11.3 kW (39 MBh) at 380 volts which will be adequate to do deliver the necessary heat.

## Air Delivery Selection

External static pressure drop through the air distribution system has been calculated to be 149.4 Pa/0.60 inches of water. Use [Table 49, p. 69](#) ([Table 50, p. 70](#)) for a WSC072ED at 4080m<sup>3</sup>/h (2400 cfm) and 149.4 Pa (0.60 wg) static pressure. The belt drive motor will give the desired airflow at a rated kW of 0.52 (0.70 bhp) and 826 rpm.



# Model Number Description—5 to 10 Tons

Y	S	C	0	6	0	E	3	R	L	A	*	*
1	2	3	4	5	6	7	8	9	10	11	12	13
<b>Digit 1—Unit Type</b>			<b>Digit 16—Hinged Service Access/ Filters</b>			<b>Digit 17—Condenser Coil Protection</b>			<b>Digit 26—System Monitoring Controls</b>			
T	DX cooling		0	Standard panels/standard filters		0	Standard coil		0	No monitoring controls		
Y	DX cooling, gas heat		A	Hinged access panels/standard filters		1	Standard coil with hail guard		A	Demand control ventilation (CO <sub>2</sub> ) <sup>10</sup>		
W	Packaged heat pump		B	Standard panels/2" MERV 8 filters		2	Black epoxy pre-coated condenser coil					
<b>Digit 2—Efficiency</b>			<b>Digit 18—Through the Base Provisions</b>			<b>Digit 19—Disconnect/Circuit Breaker (three-phase only)</b>			<b>Digit 27—Unit Hardware Enhancements</b>			
S	Standard Efficiency		0	Hinged access panels/2" MERV 8 filters		0	No through-the-base provisions		0	No enhancements		
<b>Digit 3—Airflow</b>			<b>Digit 20—Convenience Outlet</b>			<b>Digit 21—Communications Options</b>			<b>Model Number Notes</b>			
C	Convertible		0	Standard panels/2" MERV 13 filters		0	No convenience outlet		0	No enhancements		
<b>Digit 4,5,6—Nominal Gross Cooling Capacity (MBh)</b>			<b>Digit 22—Refrigeration System Option</b>			<b>Digit 23—Refrigeration Controls</b>			1. Manual outside air damper will ship factory supplied within the unit, but must be field installed.			
060	5 ton (17.6 kW)		0	CompleteCoat™ condenser coil <sup>9</sup>		0	No refrigeration control <sup>2</sup>		1	Stainless steel drain pan		
072	6 ton (21.1 kW)		1	CompleteCoat™ condenser coil with hail guard <sup>9</sup>		1	Frostat™ <sup>6</sup>					
090	7½ ton (26.4 kW)		2			<b>Digit 24—Smoke Detector</b>			2. High pressure control crankcase heaters are standard on all units.			
102	8½ ton (29.9 kW)		3			0	No smoke detector		3. Belt drive is standard on all units.			
120	10 ton (35.1 kW)		4			<b>Digit 25—System Monitoring Controls</b>			4. Economizer with barometric relief is for downflow configured units only. Order economizer without barometric relief for horizontal configuration. Barometric relief for horizontal configured units must be ordered as field-installed accessory.			
<b>Digit 7—Major Design Sequence</b>			<b>Digit 26—System Monitoring Controls</b>			<b>Digit 27—Unit Hardware Enhancements</b>			5. Standard metering devices are TXVs.			
E	R-410A refrigerant		0	No monitoring controls		0	No enhancements		6. Frostat is available as factory-installed option only.			
<b>Digit 8—Voltage Selection</b>			<b>Digit 27—Unit Hardware Enhancements</b>			<b>Model Number Notes</b>			7. Electric heaters are available only for field-installed options.			
D	380-415/50/3		1	Stainless steel drain pan		1. Manual outside air damper will ship factory supplied within the unit, but must be field installed.			8. Available only for gas heat models.			
<b>Digit 9—Unit Controls</b>			<b>Model Number Notes</b>			2. High pressure control crankcase heaters are standard on all units.			9. Not available on heat pumps.			
R	ReliaTel™ microprocessor		1. Manual outside air damper will ship factory supplied within the unit, but must be field installed.			3. Belt drive is standard on all units.			10. Demand control ventilation option includes wiring only. The CO <sub>2</sub> sensor is a field-installed only option.			
K	European		2. High pressure control crankcase heaters are standard on all units.			4. Economizer with barometric relief is for downflow configured units only. Order economizer without barometric relief for horizontal configuration. Barometric relief for horizontal configured units must be ordered as field-installed accessory.						
<b>Digit 10—Heating Capacity</b>			3. Belt drive is standard on all units.			5. Standard metering devices are TXVs.						
0	No electric heat <sup>7</sup>		4. Economizer with barometric relief is for downflow configured units only. Order economizer without barometric relief for horizontal configuration. Barometric relief for horizontal configured units must be ordered as field-installed accessory.			6. Frostat is available as factory-installed option only.						
L	Low heat <sup>8</sup>		5. Standard metering devices are TXVs.			7. Electric heaters are available only for field-installed options.						
H	High heat <sup>8</sup>		6. Frostat is available as factory-installed option only.			8. Available only for gas heat models.						
<b>Digit 11—Minor Design Sequence</b>			7. Electric heaters are available only for field-installed options.			9. Not available on heat pumps.						
A	First sequence		8. Available only for gas heat models.			10. Demand control ventilation option includes wiring only. The CO <sub>2</sub> sensor is a field-installed only option.						
<b>Digit 12,13—Service Sequence</b>			9. Not available on heat pumps.									
**	Factory assigned		10. Demand control ventilation option includes wiring only. The CO <sub>2</sub> sensor is a field-installed only option.									
<b>Digit 14—Fresh Air Selection</b>												
0	No Fresh air											
A	Manual outside air damper 0–50% <sup>1</sup>											
B	Motorized Outside air damper 0–50%											
C	Economizer, dry bulb 0–100% without barometric relief <sup>4</sup>											
D	Economizer, dry bulb 0–100% with barometric relief <sup>4</sup>											
E	Economizer, reference enthalpy 0–100% without barometric relief <sup>3,4</sup>											
F	Economizer, reference enthalpy 0–100% with barometric relief <sup>3,4</sup>											
G	Economizer, comparative enthalpy 0–100% without barometric relief <sup>3,4</sup>											
H	Economizer, comparative enthalpy 0–100% with barometric relief <sup>3,4</sup>											
<b>Digit 15—Supply Fan/Drive Type/ Motor</b>												
0	Standard drive <sup>3</sup>											
1	Oversized motor											



# General Data

**Table 1. General data—5 to 10 tons cooling and gas/electric, standard efficiency**

	<b>5 Tons</b>	<b>6 Tons</b>	<b>7½ Tons</b>	<b>8 Tons</b>	<b>10 Tons</b>
	<b>T/YSC060ED</b>	<b>T/YSC072ED</b>	<b>T/YSC090ED</b>	<b>T/YSC102ED</b>	<b>T/YSC120ED</b>
<b>Cooling Performance<sup>(a)</sup></b>					
Gross Cooling - kW (MBh)	18.2 (62.0)	23.2 (79.0)	27.0 (92.0)	30.8 (105.0)	34.9 (119.0)
COP (EER) <sup>(b)</sup>	3.05 (10.4)	3.08 (10.5)	2.96 (10.1)	2.96 (10.1)	2.78 (9.5)
Nominal Airflow - m <sup>3</sup> /h (cfm)	3400 (2000)	4080 (2400)	5100 (3000)	5780 (3400)	6800 (4000)
ARI Rated Airflow - m <sup>3</sup> /h (cfm)	3400 (2000)	3570 (2100)	4460 (2625)	5050 (2975)	5950 (3500)
Net Capacity - kW (MBh)	17.6 (60.0)	22.0 (75.0)	25.2 (86.0)	29.3 (100.0)	32.5 (111.0)
IEER	—	11.46	10.73	11.84	10.97
System Power (kW)	5.77	7.14	8.51	9.90	11.68
<b>Compressor</b>					
Number/Type	1/Scroll	1/Scroll	1/Scroll	2/Scroll	2/Scroll
<b>Sound</b>					
Outdoor Sound Rating (dB) <sup>(c)</sup>	80	85	85	83	79
<b>Outdoor Coil - Type</b>					
Configuration	Lanced	Lanced	Lanced	Lanced	Lanced
Tube Size OD mm (in)	Full Face	Full Face	Full Face	Intertwined	Intertwined
Face Area m <sup>2</sup> (sq ft)	7.94 (0.3125)	7.94 (0.3125)	7.94 (0.3125)	7.94 (0.3125)	7.94 (0.3125)
Rows/FPI	1.02 (10.96)	1.58 (17.00)	1.58 (17.00)	1.84 (19.83)	1.84 (19.83)
	3/16	3/16	3/16	3/16	3/16
<b>Indoor Coil - Type</b>					
Configuration	Lanced	Lanced	Lanced	Lanced	Lanced
Tube Size OD mm (in)	Full Face	Full Face	Full Face	Face Split	Face Split
Face Area m <sup>2</sup> (sq ft)	7.94 (0.3125)	7.94 (0.313)	7.94 (0.313)	7.94 (0.3125)	7.94 (0.3125)
Rows/FPI	0.72 (7.71)	0.92 (9.89)	0.92 (9.89)	1.15 (12.36)	1.15 (12.36)
Refrigerant Control	3/16	3/16	3/16	3/16	4/16
Drain Connection Number/Size (in)	Expansion Valve	Expansion Valve	Expansion Valve	Expansion Valve	Expansion Valve
	1/0.75 NPT	1/0.75 NPT	1/0.75 NPT	1/0.75 NPT	1/0.75 NPT
<b>Outdoor Fan - Type</b>					
Number Used/Diameter (in.)	Propeller	Propeller	Propeller	Propeller	Propeller
Drive Type/No. Speeds	1/560 (22)	1/660 (26)	1/660 (26)	1/660 (26)	1/660 (26)
Air Flow - m <sup>3</sup> /h (ft <sup>3</sup> /min.)	Direct/1	Direct/1	Direct/1	Direct/1	Direct/1
No. Motor kW (HP)	4390 (2900)	8660 (5100)	8830 (5200)	9340 (5500)	9850 (5800)
Motor rpm	1/0.3 (0.40)	1/0.56 (0.75)	1/0.56 (0.75)	1/0.56 (0.75)	1/0.56 (0.75)
	950	950	950	950	950
<b>Belt Drive Indoor Fan - Type</b>					
Number Used/Diameter (in)/Width (in)	FC Centrifugal	FC Centrifugal	FC Centrifugal	FC Centrifugal	FC Centrifugal
Drive Type/Number Speeds	1 280x280 (11x11)	1 305x305 (12x12)	1 305x305 (12x12)	1 381x381 (12x12)	1 381x381 (15x15)
Number Motors	Belt/Variable Speed	Belt/Variable Speed	Belt/Variable Speed	Belt/Variable Speed	Belt/Variable Speed
Standard Motor Power - kW (HP)	1	1	1	1	1
Oversized Motor Power - kW (HP)	1.1 (1.5)	1.1 (1.5)	1.5 (2.0)	1.5 (2.0)	2.2 (3.0)
Motor RPM - Standard/Oversized	—	—	2.2 (3.0)	2.2 (3.0)	—
Motor Frame Size	1450/—	1450/—	1450/2850	1450/2850	2850/—
	56	56	56	56	56
<b>Filters<sup>(d)</sup></b>					
Type Furnished	Throwaway	Throwaway	Throwaway	Throwaway	Throwaway
(No.) Size Recommended - mm	(2) 508x762x50	(4) 406x635x50	(4) 406x635x50	(4) 508x635x50	(4) 508x635x50
(No.) Size Recommended - in	(2) 20x30x2	(4) 16x25x2	(4) 16x25x2	(4) 20x25x2	(4) 20x25x2
<b>Refrigerant Charge<sup>(e)</sup></b>					
kg (lbs.) of R-410A	3.49 (7.7)	5.35 (11.8)	5.44 (12.0)	Circuit 1 - 3.49 (7.7) Circuit 2 - 2.63 (5.8)	Circuit 1 - 3.63 (8.0) Circuit 2 - 2.86 (6.3)

continued on next page

**Table 1. General data—5 to 10 tons cooling and gas/electric, standard efficiency (continued)**

	<b>5 Tons</b>	<b>6 Tons</b>	<b>7½ Tons</b>	<b>8 Tons</b>	<b>10 Tons</b>
	<b>T/YSC060ED</b>	<b>T/YSC072ED</b>	<b>T/YSC090ED</b>	<b>T/YSC102ED</b>	<b>T/YSC120ED</b>
<b>Heating Performance<sup>(f)</sup></b>					
<b>(Gas/Electric Only)</b>					
<b>Heating Models</b>					
Low	G80	G120	G120	G150	G150
High	G120	G200	G200	G250	G250
<b>Heating Input - kw (MBh)</b>					
Low	19.6 (67)	29.3 (100)	29.3 (100)	36.7 (125)	36.7 (125)
High	29.3 (100)	48.9 (167)	48.9 (167)	60.9 (208)	60.9 (208)
<b>Heating Output - kw (MBh)</b>					
Low	15.7 (54)	23.4 (80)	23.4 (80)	29.3 (100)	29.3 (100)
High	23.4 (80)	39.1 (134)	39.1 (134)	48.7 (166)	48.7 (166)
<b>Steady State Efficiency%</b>					
Low	80	80	80	80	80
High	80	80	80	80	80
<b>No. Burners</b>					
Low	2	3	3	3	3
High	3	4	4	5	5
<b>No. Stages</b>					
Low	1	1	1	2	2
High	1	2	2	2	2
<b>Gas Supply Line Pressure</b>					
G20 (minimum/maximum) (MB)	17/25	17/25	17/25	17/25	17/25
G25 (minimum/maximum) (MB)	20/30	20/30	20/30	20/30	20/30
G31 (minimum/maximum) (MB)	25/45	25/45	25/45	25/45	25/45
<b>Gas Connection Pipe Size (in)</b>					
Low	1/2 NPT	1/2 NPT	1/2 NPT	3/4 NPT	3/4 NPT
High	1/2 NPT	3/4 NPT	3/4 NPT	3/4 NPT	3/4 NPT

(a) Cooling performance is rated at 35°C (95°F) ambient, 27°C (80°F) entering dry bulb, 19°C (67°F) entering wet bulb. Gross capacity does not include the effect of fan motor heat. Net capacity includes the effect of fan motor heat. Units are suitable for operation to ±20% of nominal cfm. Units are certified in accordance with the Unitary Air-Conditioner Equipment certification program, which is based on ARI Standard 210/240 or 340/360, depending below or above 19,000 W (65,000 Btu/h).

(b) EER is rated at ARI conditions.

(c) Outdoor Sound Rating shown is tested in accordance with ARI Standard 270. For more information refer to Performance Data Table "Sound Power Level".

(d) Optional 2" MERV 8 and MERV 13 filters also available.

(e) Refrigerant charge is an approximate value. For a more precise value, see unit nameplate and service instructions.

(f) Heating performance limit settings and rating data were established and approved under laboratory test conditions using American National Standards Institute standards. Ratings shown are for elevations up to 2000 feet. For elevations above 2000 feet, ratings should be reduced at the rate of 4% for each 1000 feet above sea level. Applicable to Gas/Electric units only.



## General Data

**Table 2. General data—5 to 10 tons heat pumps, standard efficiency**

	5 Tons	6 Tons	7½ Tons	10 Tons
	WSC060ED	WSC072ED	WSC090ED	WSC120ED
<b>Cooling Performance<sup>(a)</sup></b>				
Gross Cooling - kW (MBh)	17.6 (60.0)	23.4 (80.0)	28.1 (96.0)	35.8 (122.0)
COP (EER) <sup>(b)</sup>	3.05 (10.4)	3.37 (11.5)	3.11 (10.6)	2.93 (10.0)
Nominal Airflow - m <sup>3</sup> /h (cfm)	3400 (2000)	4080 (2400)	5100 (3000)	6800 (4000)
ARI Rated Airflow - m <sup>3</sup> /h (cfm)	3400 (2000)	3570 (2100)	4460 (2625)	5950 (3500)
Net Capacity - kW (MBh)	17.0 (58.0)	22.3 (76.0)	26.7 (91.0)	33.7 (115.0)
IEER	—	12.53	11.41	11.54
System Power (kW)	5.58	6.61	8.58	11.50
<b>Heating Performance<sup>(a)</sup></b>				
High Temperature Capacity - kW (MBh)	15.8 (54.0)	21.1 (72.0)	26.4 (90.0)	33.7 (115.0)
COP	3.30	3.40	3.60	3.60
System Power - kW	4.79	6.21	7.33	9.36
<b>Compressor</b>				
Number/Type	1/Scroll	1/Scroll	1/Scroll	2/Scroll
<b>Sound</b>				
Outdoor Sound Rating (dB) <sup>(c)</sup>	80	85	85	79
<b>Outdoor Coil - Type</b>				
Configuration	Lanced	Lanced	Lanced	Lanced
Tube Size OD mm (in)	7.94 (0.3125)	7.94 (0.3125)	7.94 (0.3125)	7.94 (0.3125)
Face Area m <sup>2</sup> (sq ft)	1.02 (10.96)	1.58 (17.00)	1.58 (17.00)	1.84 (19.83)
Rows/FPI	3/16	3/16	3/16	3/16
Refrigerant Control	Expansion Valve	Expansion Valve	Expansion Valve	Expansion Valve
<b>Indoor Coil - Type</b>				
Configuration	Lanced	Lanced	Lanced	Lanced
Tube Size OD mm (in)	7.94 (0.3125)	7.94 (0.3125)	7.94 (0.3125)	7.94 (0.3125)
Face Area m <sup>2</sup> (sq ft)	0.72 (7.71)	0.92 (9.89)	0.92 (9.89)	1.15 (12.36)
Rows/FPI	3/16	3/16	4/16	4/16
Refrigerant Control	Short Orifice	Short Orifice	Short Orifice	Short Orifice
Drain Connection Number/Size (in)	1/0.75 NPT	1/0.75 NPT	1/0.75 NPT	1/0.75 NPT
<b>Outdoor Fan - Type</b>				
Number Used/Diameter (inches)	Propeller 1/560 (22)	Propeller 1/660 (26)	Propeller 1/660 (26)	Propeller 1/660 (26)
Drive Type/No. Speeds	Direct/1	Direct/1	Direct/1	Direct/1
Face Area m <sup>3</sup> /h (ft <sup>3</sup> /min)	4925 (2900)	8660 (5100)	8830 (5200)	9848 (5800)
No. Motor/kW (HP)	1/0.3 (0.40)	1/0.56 (0.75)	1/0.56 (0.75)	1/0.56 (0.75)
Motor rpm	950	950	950	950
<b>Belt Drive Indoor Fan - Type</b>				
Number Used/Diameter (in)/Width (in)	FC Centrifugal 1 280x280 (11x11)	FC Centrifugal 1 305x305 (12x12)	FC Centrifugal 1 305x305 (12x12)	FC Centrifugal 1 381x381 (15x15)
Drive Type/Number Speeds	Belt/Variable Speed	Belt/Variable Speed	Belt/Variable Speed	Belt/Variable Speed
Number Motors	1	1	1	1
Standard Motor Power - kW (HP)	1.1 (1.5)	1.1 (1.5)	1.5 (2.0)	2.2 (3.0)
Oversized Motor Power - kW (HP)	—	—	2.2 (3.0)	—
Motor RPM - Standard/Oversized	1450/—	1450/—	1450/2850	2850/—
Motor Frame Size	56	56	56	56
<b>Filters<sup>(d)</sup></b>				
Type Furnished	Throwaway	Throwaway	Throwaway	Throwaway
(No.) Size Recommended - mm	(2) 508x762x50	(4) 406x635x50	(4) 406x635x50	(4) 508x635x50
(No.) Size Recommended - in	(2) 20x30x2	(4) 16x25x2	(4) 16x25x2	(4) 20x25x2
<b>Refrigerant Charge<sup>(e)</sup> - kg (lbs) of R-410A</b>				
	3.86 (8.5)	5.53 (12.2)	6.17 (13.6)	Circuit 1 - 3.31 (7.3) Circuit 2 - 2.99 (6.6)

(a) Cooling performance is rated at 35°C (95°F) ambient, 27°C (80°F) entering dry bulb, 19°C (67°F) entering wet bulb. Gross capacity does not include the effect of fan motor heat. Net capacity includes the effect of fan motor heat. Units are suitable for operation to ±20% of nominal cfm. Units are certified in accordance with the Unitary Air-Conditioner Equipment certification program, which is based on ARI Standard 210/240 or 340/360, depending below or above 19,000 W (65,000 Btu/h).

(b) EER is rated at ARI conditions.

(c) Outdoor Sound Rating shown is tested in accordance with ARI Standard 270. For more information refer to Performance Data Table "Sound Power Level".

(d) Optional 2" MERV 8 and MERV 13 filters also available.

(e) Refrigerant charge is an approximate value. For a more precise value, see unit nameplate and service instructions.



# Performance Data

**Table 1. Gross cooling capacities kW 5 tons standard efficiency—T/YSC060ED (SI)**

		Ambient Temperature																	
		30						35						40					
m <sup>3</sup> /h Airflow	Ent	Entering Wet Bulb						Entering Wet Bulb						Entering Wet Bulb					
	DB	16		19		22		16		19		22		16		19		22	
	(C)	TGC	SHC	TGC	SHC	TGC	SHC	TGC	SHC	TGC	SHC	TGC	SHC	TGC	SHC	TGC	SHC	TGC	SHC
2720	24	16.87	13.59	18.20	9.82	20.00	4.31	15.89	13.02	17.13	9.37	18.84	3.97	14.85	12.39	16.00	8.86	17.61	3.58
2720	27	17.35	15.87	18.44	13.01	20.00	8.42	16.37	15.22	17.38	12.49	18.85	8.01	15.33	14.51	16.24	11.90	17.62	7.54
2720	30	17.96	17.67	18.82	15.73	20.14	12.05	16.99	16.95	17.75	15.13	18.99	11.57	15.95	15.95	16.63	14.47	17.77	11.02
2720	33	18.70	18.70	19.32	17.98	20.41	15.21	17.73	17.73	18.26	17.30	19.26	14.65	16.97	16.97	17.14	16.56	18.05	14.03
3060	24	17.34	14.14	18.61	10.29	20.34	4.70	16.33	13.53	17.50	9.80	19.15	4.32	15.24	12.86	16.33	9.25	17.88	3.89
3060	27	17.87	16.48	18.90	13.54	20.40	8.86	16.86	15.79	17.80	12.97	19.21	8.41	15.79	15.05	16.64	12.35	17.95	7.91
3060	30	18.54	18.34	19.33	16.32	20.59	12.56	17.53	17.53	18.24	15.68	19.41	12.03	16.46	16.46	17.07	14.98	18.15	11.45
3060	33	19.33	19.33	19.89	18.63	20.92	15.78	18.33	18.33	18.80	17.91	19.74	15.18	17.47	17.47	17.64	17.14	18.49	14.53
3400	24	17.75	14.62	18.95	10.69	20.63	5.02	16.70	13.98	17.81	10.16	19.40	4.60	15.58	13.27	16.61	9.57	18.10	4.13
3400	27	18.34	17.02	19.31	14.00	20.74	9.24	17.29	16.30	18.17	13.40	19.52	8.76	16.18	15.52	16.97	12.74	18.22	8.21
3400	30	19.06	18.95	19.79	16.85	20.99	13.00	18.02	18.02	18.66	16.17	19.77	12.44	16.91	16.91	17.46	15.43	18.48	11.82
3400	33	19.91	19.91	20.41	19.21	21.37	16.28	18.87	18.87	19.28	18.46	20.16	15.65	17.91	17.91	18.09	17.65	18.87	14.95
3740	24	18.10	15.04	19.24	11.03	20.85	5.27	17.01	14.36	18.07	10.46	19.59	4.82	15.86	13.61	16.83	9.83	18.26	4.31
3740	27	18.74	17.50	19.65	14.40	21.03	9.56	17.66	16.74	18.48	13.76	19.77	9.03	16.52	15.92	17.24	13.06	18.44	8.45
3740	30	19.52	19.49	20.19	17.30	21.33	13.37	18.44	18.44	19.03	16.59	20.07	12.78	17.30	17.30	17.79	15.81	18.75	12.12
3740	33	20.43	20.43	20.86	19.73	21.77	16.72	19.36	19.36	19.70	18.94	20.52	16.04	18.29	18.29	18.48	18.09	19.20	15.31
4080	24	18.39	15.40	19.47	11.30	21.02	5.46	17.27	14.67	18.26	10.69	19.72	4.97	16.09	13.89	16.99	10.03	18.36	4.42
4080	27	19.09	17.92	19.94	14.73	21.25	9.81	17.98	17.12	18.73	14.05	19.96	9.25	16.80	16.26	17.46	13.32	18.59	8.62
4080	30	19.92	19.92	20.53	17.70	21.61	13.69	18.82	18.82	19.34	16.94	20.32	13.05	17.64	17.64	18.07	16.13	18.96	12.35
4080	33	20.89	20.89	21.26	20.19	22.11	17.09	19.79	19.79	20.07	19.36	20.82	16.38	18.62	18.62	18.81	18.47	19.47	15.61
		Ambient Temperature																	
		45						52											
m <sup>3</sup> /h Airflow	Ent	Entering Wet Bulb						Entering Wet Bulb											
	DB	16		19		22		16		19		22							
	(C)	TGC	SHC	TGC	SHC	TGC	SHC	TGC	SHC	TGC	SHC	TGC	SHC						
2720	24	13.73	11.70	14.79	8.28	16.32	3.13	12.55	10.95	13.52	7.65	14.95	2.61						
2720	27	14.22	13.75	15.04	11.25	16.33	7.01	13.05	12.93	13.78	10.55	14.98	6.42						
2720	30	14.85	14.85	15.43	13.75	16.48	10.42	13.67	13.67	14.17	12.97	15.13	9.76						
2720	33	15.79	15.79	15.95	15.77	16.77	13.36	14.69	14.69	14.69	14.69	15.42	12.62						
3060	24	14.10	12.13	15.09	8.64	16.55	3.40	12.88	11.35	13.79	7.97	15.16	2.85						
3060	27	14.64	14.25	15.40	11.67	16.63	7.34	13.43	13.39	14.10	10.92	15.24	6.72						
3060	30	15.32	15.32	15.84	14.22	16.83	10.81	14.11	14.11	14.55	13.41	15.45	10.12						
3060	33	16.25	16.25	16.42	16.31	17.17	13.81	15.13	15.13	15.13	15.13	15.79	13.04						
3400	24	14.40	12.50	15.33	8.93	16.73	3.60	13.15	11.68	13.99	8.22	15.30	3.02						
3400	27	15.00	14.68	15.70	12.02	16.86	7.61	13.76	13.76	14.36	11.24	15.44	6.95						
3400	30	15.74	15.74	16.20	14.63	17.13	11.14	14.50	14.50	14.87	13.78	15.71	10.40						
3400	33	16.66	16.66	16.83	16.78	17.52	14.20	15.50	15.50	15.50	15.50	16.10	13.39						
3740	24	14.65	12.81	15.52	9.15	16.86	3.74	13.36	11.95	14.14	8.41	15.39	3.12						
3740	27	15.31	15.05	15.94	12.30	17.04	7.81	14.03	14.03	14.57	11.48	15.58	7.11						
3740	30	16.10	16.10	16.50	14.98	17.36	11.40	14.82	14.82	15.13	14.09	15.91	10.63						
3740	33	17.18	17.18	17.18	17.18	17.81	14.52	15.82	15.82	15.82	15.82	16.36	13.68						
4080	24	14.84	13.05	15.64	9.31	16.92	3.82	13.52	12.15	14.24	8.53	15.42	3.16						
4080	27	15.55	15.35	16.12	12.52	17.17	7.95	14.24	14.24	14.72	11.66	15.67	7.21						
4080	30	16.40	16.40	16.74	15.26	17.54	11.60	15.09	15.09	15.34	14.33	16.05	10.79						
4080	33	17.48	17.48	17.48	17.48	18.05	14.78	16.08	16.08	16.08	16.08	16.56	13.90						

**Notes:**

1. All capacities shown are gross and have not considered indoor fan heat. To obtain **NET** cooling capacity subtract indoor fan heat. For indoor fan heat formula, refer to appropriate airflow table notes.
2. TGC = Total Gross Capacity
3. SHC = Sensible Heat Capacity



## Performance Data

**Table 2. Gross cooling capacities MBh 5 tons standard efficiency – T/YSC060ED (IP)**

CFM Airflow		Ent DB (F)		Ambient Temperature															
				85				95				105							
				Entering Wet Bulb				Entering Wet Bulb				Entering Wet Bulb							
				61		67		73		61		67		73		61		67	
		TGC	SHC	TGC	SHC	TGC	SHC	TGC	SHC	TGC	SHC	TGC	SHC	TGC	SHC	TGC	SHC	TGC	SHC
1600	75	57.58	46.37	62.11	33.52	68.24	14.71	54.23	44.42	58.46	31.97	64.28	13.56	50.66	42.26	54.58	30.21	60.09	12.21
1600	80	59.20	54.14	62.93	44.41	68.26	28.72	55.87	51.93	59.29	42.60	64.31	27.32	52.32	49.52	55.43	40.60	60.13	25.72
1600	85	61.27	60.29	64.20	53.68	68.72	41.12	57.96	57.83	60.58	51.62	64.79	39.46	54.42	54.42	56.73	49.36	60.63	37.61
1600	90	63.80	63.80	65.92	61.35	69.63	51.91	60.50	60.50	62.31	59.03	65.72	50.00	57.90	57.90	58.48	56.52	61.58	47.89
1800	75	59.16	48.25	63.49	35.11	69.41	16.02	55.70	46.16	59.72	33.43	65.33	14.74	52.01	43.88	55.72	31.55	61.02	13.27
1800	80	60.98	56.22	64.50	46.21	69.61	30.24	57.53	53.88	60.75	44.27	65.55	28.71	53.86	51.35	56.76	42.14	61.26	26.98
1800	85	63.24	62.58	65.96	55.69	70.27	42.85	59.82	59.82	62.22	53.50	66.22	41.06	56.16	56.16	58.26	51.11	61.95	39.08
1800	90	65.96	65.96	67.87	63.56	71.38	53.84	62.55	62.55	64.15	61.12	67.35	51.80	59.60	59.60	60.20	58.48	63.08	49.56
2000	75	60.55	49.90	64.67	36.48	70.38	17.11	56.98	47.69	60.78	34.67	66.18	15.70	53.17	45.27	56.66	32.66	61.75	14.10
2000	80	62.56	58.08	65.87	47.79	70.77	31.54	59.00	55.61	62.00	45.72	66.59	29.88	55.21	52.95	57.90	43.46	62.18	28.02
2000	85	65.02	64.65	67.53	57.48	71.62	44.35	61.47	61.47	63.67	55.16	67.46	42.44	57.70	57.70	59.59	52.64	63.06	40.32
2000	90	67.93	67.93	69.63	65.56	72.92	55.55	64.40	64.40	65.79	62.98	68.77	53.38	61.10	61.10	61.72	60.21	64.40	51.02
2200	75	61.75	51.33	65.65	37.63	71.15	17.98	58.05	48.99	61.65	35.69	66.83	16.44	54.13	46.45	57.41	33.55	62.29	14.71
2200	80	63.95	59.72	67.05	49.14	71.74	32.61	60.27	57.12	63.06	46.95	67.44	30.82	56.36	54.33	58.84	44.56	62.91	28.83
2200	85	66.60	66.49	68.89	59.04	72.78	45.63	62.94	62.94	64.92	56.59	68.50	43.59	59.04	59.04	60.72	53.95	63.99	41.35
2200	90	69.70	69.70	71.19	67.33	74.27	57.04	66.05	66.05	67.23	64.63	70.01	54.75	62.42	62.42	63.05	61.73	65.51	52.25
2400	75	62.75	52.54	66.44	38.56	71.72	18.62	58.93	50.07	62.32	36.49	67.29	16.96	54.89	47.40	57.96	34.22	62.63	15.09
2400	80	65.14	61.13	68.03	50.28	72.51	33.47	61.34	58.41	63.92	47.95	68.09	31.55	57.31	55.49	59.58	45.43	63.44	29.43
2400	85	67.98	67.98	70.07	60.38	73.74	46.70	64.20	64.20	65.97	57.81	69.34	44.52	60.19	60.19	61.65	55.03	64.71	42.15
2400	90	71.28	71.28	72.56	68.88	75.43	58.31	67.51	67.51	68.48	66.05	71.04	55.89	63.53	63.53	64.18	63.02	66.43	53.26
CFM Airflow		Ent DB (F)		Ambient Temperature															
				115				125											
				Entering Wet Bulb				Entering Wet Bulb											
				61		67		73		61		67		73					
		TGC	SHC	TGC	SHC	TGC	SHC	TGC	SHC	TGC	SHC	TGC	SHC	TGC	SHC	TGC	SHC	TGC	SHC
1600	75	46.86	39.91	50.47	28.27	55.67	10.67	42.83	37.36	46.13	26.12	51.02	8.92						
1600	80	48.53	46.92	51.33	38.39	55.73	23.92	44.52	44.11	47.01	35.99	51.10	21.92						
1600	85	50.65	50.65	52.65	46.91	56.24	35.55	46.66	46.66	48.34	44.25	51.63	33.30						
1600	90	53.87	53.87	54.42	53.81	57.20	45.58	50.13	50.13	50.13	50.13	52.60	43.08						
1800	75	48.10	41.40	51.49	29.47	56.48	11.59	43.95	38.72	47.04	27.19	51.72	9.72						
1800	80	49.96	48.61	52.55	39.81	56.74	25.05	45.83	45.68	48.11	37.28	51.99	22.92						
1800	85	52.27	52.27	54.06	48.53	57.44	36.89	48.16	48.16	49.63	45.75	52.70	34.51						
1800	90	55.46	55.46	56.02	55.64	58.59	47.13	51.61	51.61	51.61	51.61	53.88	44.49						
2000	75	49.13	42.66	52.32	30.46	57.10	12.29	44.87	39.86	47.75	28.05	52.21	10.29						
2000	80	51.19	50.08	53.57	41.00	57.54	25.96	46.94	46.94	49.01	38.34	52.68	23.70						
2000	85	53.70	53.70	55.27	49.93	58.44	38.01	49.46	49.46	50.73	47.02	53.59	35.50						
2000	90	56.85	56.85	57.42	57.25	59.79	48.45	52.90	52.90	52.90	52.90	54.95	45.69						
2200	75	49.97	43.71	52.95	31.22	57.52	12.77	45.59	40.77	48.26	28.68	52.52	10.64						
2200	80	52.22	51.34	54.39	41.97	58.15	26.65	47.86	47.86	49.72	39.18	53.17	24.26						
2200	85	54.92	54.92	56.29	51.11	59.24	38.91	50.57	50.57	51.63	48.07	54.27	36.27						
2200	90	58.63	58.63	58.63	58.63	60.78	49.56	53.99	53.99	53.99	53.99	55.83	46.67						
2400	75	50.62	44.53	53.38	31.76	57.74	13.03	46.12	41.46	48.57	29.09	52.62	10.77						
2400	80	53.06	52.37	55.02	42.72	58.57	27.11	48.58	48.58	50.22	39.80	53.47	24.60						
2400	85	55.95	55.95	57.10	52.06	59.85	39.58	51.48	51.48	52.33	48.89	54.76	36.82						
2400	90	59.64	59.64	59.64	59.64	61.58	50.44	54.88	54.88	54.88	54.88	56.51	47.42						

**Notes:**

1. All capacities shown are gross and have not considered indoor fan heat. To obtain **NET** cooling capacity subtract indoor fan heat. For indoor fan heat formula, refer to appropriate airflow table notes.
2. TGC = Total Gross Capacity
3. SHC = Sensible Heat Capacity



**Table 3. Gross cooling capacities kw 6 tons standard efficiency – T/YSC072ED (SI)**

m <sup>3</sup> /h Airflow		Ent DB (C)		Ambient Temperature															
				30				35				40							
				Entering Wet Bulb				Entering Wet Bulb				Entering Wet Bulb							
				16	19	22		16	19	22		16	19	22		16	19	22	
TGC	SHC	TGC	SHC	TGC	SHC	TGC	SHC	TGC	SHC	TGC	SHC	TGC	SHC	TGC	SHC	TGC	SHC		
3260	24	21.22	16.71	23.22	12.41	25.92	6.23	19.94	15.95	21.81	11.80	24.39	5.77	18.58	15.13	20.33	11.13	22.78	5.24
3260	27	21.75	19.40	23.40	16.06	25.77	10.84	20.47	18.55	22.00	15.36	24.24	10.28	19.12	17.64	20.52	14.60	22.64	9.66
3260	30	22.48	21.57	23.79	19.19	25.82	14.93	21.21	20.63	22.40	18.40	24.30	14.28	19.86	19.63	20.92	17.55	22.70	13.57
3260	33	23.42	23.23	24.39	21.81	26.08	18.50	22.16	22.16	23.00	20.92	24.57	17.76	20.81	20.81	21.53	19.98	22.97	16.96
3670	24	21.88	17.39	23.81	12.96	26.44	6.65	20.56	16.59	22.36	12.31	24.87	6.14	19.15	15.74	20.83	11.60	23.21	5.58
3670	27	22.48	20.17	24.06	16.70	26.36	11.35	21.16	19.29	22.62	15.96	24.79	10.75	19.76	18.34	21.09	15.16	23.14	10.10
3670	30	23.28	22.44	24.52	19.93	26.48	15.53	21.97	21.46	23.08	19.10	24.92	14.85	20.57	20.43	21.56	18.21	23.27	14.10
3670	33	24.29	24.19	25.19	22.64	26.81	19.19	22.98	22.98	23.76	21.71	25.25	18.42	21.59	21.59	22.24	20.73	23.61	17.58
4080	24	22.46	18.00	24.32	13.44	26.89	7.00	21.09	17.17	22.82	12.76	25.27	6.46	19.64	16.28	21.25	12.01	23.56	5.85
4080	27	23.13	20.88	24.64	17.28	26.87	11.79	21.76	19.96	23.15	16.50	25.26	11.16	20.32	18.98	21.58	15.67	23.56	10.47
4080	30	24.00	23.24	25.17	20.60	27.06	16.07	22.64	22.23	23.69	19.73	25.45	15.35	21.20	21.16	22.12	18.80	23.76	14.56
4080	33	25.07	25.07	25.91	23.40	27.46	19.83	23.72	23.72	24.43	22.44	25.85	19.01	22.29	22.29	22.87	21.43	24.17	18.14
4490	24	22.96	18.55	24.75	13.86	27.25	7.28	21.55	17.69	23.21	13.14	25.58	6.71	20.05	16.76	21.59	12.35	23.84	6.07
4490	27	23.70	21.53	25.14	17.79	27.30	12.17	22.29	20.57	23.61	16.98	25.64	11.50	20.80	19.55	21.99	16.11	23.90	10.78
4490	30	24.64	23.98	25.74	21.21	27.56	16.54	23.23	22.94	24.21	20.30	25.91	15.78	21.75	21.75	22.60	19.34	24.17	14.97
4490	33	25.78	25.78	26.55	24.10	28.03	20.40	24.39	24.39	25.03	23.11	26.38	19.55	22.91	22.91	23.42	22.05	24.65	18.64
4900	24	23.38	19.04	25.10	14.22	27.53	7.51	21.93	18.14	23.52	13.46	25.82	6.89	20.38	17.17	21.85	12.64	24.03	6.22
4900	27	24.19	22.11	25.56	18.24	27.65	12.49	22.73	21.11	23.98	17.39	25.95	11.78	21.20	20.06	22.32	16.48	24.16	11.02
4900	30	25.19	24.66	26.23	21.75	27.98	16.95	23.75	23.58	24.66	20.81	26.28	16.16	22.22	22.22	23.00	19.81	24.50	15.30
4900	33	26.41	26.41	27.11	24.74	28.52	20.90	24.97	24.97	25.54	23.71	26.82	20.02	23.44	23.44	23.89	22.62	25.05	19.07

m <sup>3</sup> /h Airflow		Ent DB (C)		Ambient Temperature											
				45						52					
				Entering Wet Bulb						Entering Wet Bulb					
				16	19	22		16	19	22		16	19	22	
TGC	SHC	TGC	SHC	TGC	SHC	TGC	SHC	TGC	SHC	TGC	SHC	TGC	SHC		
3260	24	17.14	14.25	18.75	10.39	21.08	4.65	15.61	13.31	17.10	9.60	19.31	4.00		
3260	27	17.68	16.67	18.96	13.77	20.95	8.98	16.16	15.64	17.31	12.89	19.17	8.24		
3260	30	18.43	18.43	19.36	16.63	21.01	12.80	16.91	16.91	17.72	15.65	19.25	11.97		
3260	33	19.38	19.38	19.98	18.97	21.29	16.10	18.16	18.16	18.34	17.91	19.53	15.18		
3670	24	17.66	14.82	19.21	10.83	21.47	4.95	16.09	13.84	17.51	10.00	19.65	4.27		
3670	27	18.27	17.33	19.48	14.30	21.40	9.38	16.70	16.27	17.79	13.38	19.58	8.60		
3670	30	19.09	19.09	19.96	17.26	21.54	13.29	17.53	17.53	18.27	16.24	19.73	12.43		
3670	33	20.12	20.12	20.64	19.69	21.88	16.69	18.77	18.77	18.96	18.59	20.08	15.73		
4080	24	18.11	15.32	19.59	11.20	21.78	5.19	16.49	14.31	17.84	10.33	19.91	4.47		
4080	27	18.79	17.93	19.93	14.77	21.78	9.72	17.17	16.83	18.19	13.81	19.91	8.90		
4080	30	19.67	19.67	20.47	17.82	21.98	13.72	18.07	18.07	18.74	16.77	20.13	12.82		
4080	33	20.77	20.77	21.23	20.35	22.40	17.21	19.31	19.31	19.50	19.21	20.55	16.21		
4490	24	18.47	15.77	19.88	11.51	22.01	5.37	16.81	14.72	18.09	10.60	20.09	4.61		
4490	27	19.22	18.47	20.29	15.17	22.07	9.99	17.56	17.33	18.51	14.17	20.16	9.14		
4490	30	20.18	20.18	20.91	18.31	22.35	14.09	18.53	18.53	19.13	17.23	20.45	13.14		
4490	33	21.34	21.34	21.73	20.94	22.83	17.67	19.76	19.76	19.96	19.76	20.94	16.64		
4900	24	18.76	16.14	20.10	11.75	22.15	5.48	17.05	15.06	18.27	10.81	20.19	4.68		
4900	27	19.58	18.94	20.58	15.51	22.29	10.19	17.88	17.76	18.75	14.48	20.34	9.30		
4900	30	20.60	20.60	21.26	18.75	22.64	14.39	18.91	18.91	19.44	17.62	20.69	13.41		
4900	33	21.84	21.84	22.16	21.47	23.19	18.06	20.14	20.14	20.34	20.25	21.25	16.99		

**Notes:**

1. All capacities shown are gross and have not considered indoor fan heat. To obtain **NET** cooling capacity subtract indoor fan heat. For indoor fan heat formula, refer to appropriate airflow table notes.
2. TGC = Total Gross Capacity
3. SHC = Sensible Heat Capacity



## Performance Data

**Table 4. Gross cooling capacities MBh 6 tons standard efficiency – T/YSC072ED (IP)**

CFM Airflow		Ent DB (F)		Ambient Temperature																	
				85						95						105					
				Entering Wet Bulb						Entering Wet Bulb						Entering Wet Bulb					
				61		67		73		61		67		73		61		67		73	
		TGC	SHC	TGC	SHC	TGC	SHC	TGC	SHC	TGC	SHC	TGC	SHC	TGC	SHC	TGC	SHC	TGC	SHC		
1920	75	72.41	57.01	79.22	42.36	88.45	21.27	68.05	54.42	74.43	40.27	83.23	19.68	63.41	51.63	69.35	37.97	77.73	17.87		
1920	80	74.20	66.19	79.85	54.81	87.92	36.99	69.86	63.30	75.08	52.41	82.72	35.08	65.23	60.19	70.02	49.80	77.24	32.97		
1920	85	76.70	73.61	81.18	65.49	88.10	50.94	72.38	70.40	76.43	62.78	82.92	48.72	67.77	66.99	71.39	59.87	77.45	46.30		
1920	90	79.91	79.26	83.23	74.40	88.98	63.12	75.60	75.60	78.49	71.39	83.82	60.60	71.01	71.01	73.48	68.16	78.37	57.87		
2160	75	74.67	59.33	81.23	44.22	90.23	22.68	70.15	56.61	76.29	42.01	84.86	20.96	65.35	53.69	71.06	39.58	79.20	19.03		
2160	80	76.69	68.83	82.10	56.99	89.94	38.72	72.20	65.81	77.17	54.47	84.58	36.69	67.41	62.58	71.96	51.74	78.95	34.46		
2160	85	79.43	76.57	83.67	68.00	90.35	52.99	74.95	73.24	78.77	65.16	85.01	50.65	70.19	69.70	73.58	62.12	79.40	48.11		
2160	90	82.87	82.54	85.95	77.23	91.47	65.49	78.41	78.41	81.06	74.09	86.15	62.85	73.67	73.67	75.89	70.74	80.55	59.99		
2400	75	76.65	61.42	82.98	45.87	91.74	23.88	71.98	58.59	77.88	43.53	86.21	22.03	67.02	55.54	72.50	40.98	80.40	19.98		
2400	80	78.91	71.25	84.08	58.96	91.68	40.24	74.26	68.11	79.00	56.31	86.17	38.08	69.32	64.75	73.64	53.45	80.38	35.72		
2400	85	81.88	79.31	85.89	70.29	92.33	54.83	77.25	75.86	80.83	67.33	86.84	52.36	72.33	72.20	75.48	64.16	81.07	49.69		
2400	90	85.55	85.55	88.40	79.85	93.68	67.65	80.94	80.94	83.36	76.58	88.21	64.88	76.05	76.05	78.04	73.11	82.46	61.90		
2640	75	78.35	63.31	84.45	47.30	92.97	24.85	73.53	60.34	79.20	44.83	87.29	22.88	68.43	57.17	73.66	42.16	81.33	20.70		
2640	80	80.85	73.46	85.78	60.71	93.15	41.53	76.05	70.18	80.55	57.94	87.49	39.25	70.96	66.71	75.04	54.95	81.55	36.77		
2640	85	84.06	81.84	87.83	72.36	94.03	56.45	79.27	78.26	82.62	69.28	88.39	53.86	74.21	74.21	77.12	65.98	82.47	51.06		
2640	90	87.97	87.97	90.58	82.24	95.62	69.59	83.21	83.21	85.39	78.85	90.00	66.70	78.16	78.16	79.91	75.25	84.10	63.59		
2880	75	79.79	64.97	85.65	48.51	93.94	25.61	74.82	61.88	80.24	45.91	88.10	23.51	69.56	58.59	74.56	43.11	81.99	21.21		
2880	80	82.52	75.44	87.22	62.25	94.35	42.61	77.57	72.04	81.84	59.34	88.54	40.21	72.33	68.44	76.17	56.24	82.44	37.59		
2880	85	85.97	84.15	89.50	74.21	95.47	57.85	81.03	80.44	84.14	71.01	89.68	55.13	75.81	75.81	78.49	67.59	83.60	52.21		
2880	90	90.12	90.12	92.49	84.42	97.30	71.32	85.20	85.20	87.14	80.90	91.52	68.29	80.00	80.00	81.51	77.17	85.46	65.06		
CFM Airflow		Ent DB (F)		Ambient Temperature																	
				115						125											
				Entering Wet Bulb						Entering Wet Bulb											
				61		67		73		61		67		73							
		TGC	SHC	TGC	SHC	TGC	SHC	TGC	SHC	TGC	SHC	TGC	SHC	TGC	SHC	TGC	SHC	TGC	SHC		
1920	75	58.47	48.62	63.99	35.46	71.94	15.86	53.26	45.42	58.35	32.75	65.87	13.65								
1920	80	60.32	56.88	64.68	46.99	71.47	30.66	55.12	53.37	59.05	43.97	65.42	28.13								
1920	85	62.88	62.88	66.07	56.74	71.70	43.68	57.70	57.70	60.47	53.41	65.67	40.84								
1920	90	66.14	66.14	68.17	64.73	72.64	54.93	61.96	61.96	62.59	61.10	66.63	51.79								
2160	75	60.27	50.57	65.55	36.95	73.26	16.90	54.90	47.23	59.75	34.11	67.04	14.56								
2160	80	62.35	59.15	66.47	48.80	73.02	32.01	57.00	55.50	60.69	45.65	66.82	29.36								
2160	85	65.14	65.14	68.10	58.88	73.49	45.36	59.81	59.81	62.34	55.42	67.30	42.40								
2160	90	68.64	68.64	70.44	67.19	74.67	56.93	64.05	64.05	64.70	63.42	68.50	53.67								
2400	75	61.79	52.29	66.83	38.22	74.31	17.72	56.26	48.83	60.88	35.26	67.93	15.25								
2400	80	64.11	61.19	67.99	50.39	74.31	33.15	58.60	57.42	62.06	47.12	67.95	30.37								
2400	85	67.13	67.13	69.86	60.79	75.01	46.82	61.65	61.65	63.94	57.21	68.67	43.73								
2400	90	70.87	70.87	72.43	69.42	76.42	58.72	65.87	65.87	66.54	65.53	70.10	55.32								
2640	75	63.03	53.80	67.84	39.27	75.08	18.32	57.36	50.21	61.74	36.18	68.55	15.72								
2640	80	65.59	63.02	69.24	51.76	75.32	34.07	59.93	59.13	63.15	48.37	68.80	31.17								
2640	85	68.85	68.85	71.34	62.49	76.26	48.06	63.22	63.22	65.27	58.78	69.77	44.85								
2640	90	72.82	72.82	74.15	71.44	77.91	60.28	67.42	67.42	68.10	67.43	71.43	56.76								
2880	75	64.01	55.08	68.58	40.11	75.59	18.70	58.18	51.37	62.33	36.89	68.90	15.98								
2880	80	66.80	64.63	70.21	52.92	76.06	34.77	60.99	60.61	63.98	49.40	69.39	31.75								
2880	85	70.30	70.30	72.55	63.96	77.24	49.08	64.51	64.51	66.33	60.13	70.59	45.75								
2880	90	74.51	74.51	75.60	73.24	79.12	61.63	68.70	68.70	69.40	69.10	72.49	57.98								

**Notes:**

1. All capacities shown are gross and have not considered indoor fan heat. To obtain **NET** cooling capacity subtract indoor fan heat. For indoor fan heat formula, refer to appropriate airflow table notes.
2. TGC = Total Gross Capacity
3. SHC = Sensible Heat Capacity

**Table 5. Gross cooling capacities kw 7½ tons standard efficiency—T/YSC090ED (SI)**

m <sup>3</sup> /h Airflow		Ent DB (C)		Ambient Temperature															
				30				35				40							
				Entering Wet Bulb				Entering Wet Bulb				Entering Wet Bulb							
				16	19	22		16	19	22		16	19	22		16	19	22	
TGC	SHC	TGC	SHC	TGC	SHC	TGC	SHC	TGC	SHC	TGC	SHC	TGC	SHC	TGC	SHC	TGC	SHC		
4080	24	24.95	19.81	27.01	14.23	29.81	6.15	23.49	18.94	25.41	13.51	28.07	5.58	21.97	18.00	23.75	12.74	26.26	4.96
4080	27	25.67	23.19	27.36	18.91	29.79	12.11	24.22	22.21	25.77	18.08	28.05	11.44	22.69	21.17	24.10	17.19	26.24	10.71
4080	30	26.60	25.89	27.93	22.90	29.99	17.39	25.15	24.80	26.33	21.96	28.25	16.61	23.62	23.62	24.66	20.96	26.44	15.77
4080	33	27.73	27.73	28.69	26.19	30.39	21.98	26.28	26.28	27.10	25.15	28.65	21.09	24.76	24.76	25.44	24.04	26.84	20.14
4590	24	25.65	20.59	27.63	14.89	30.34	6.68	24.15	19.67	25.98	14.12	28.55	6.06	22.57	18.68	24.26	13.29	26.69	5.39
4590	27	26.44	24.07	28.06	19.66	30.40	12.74	24.94	23.04	26.41	18.78	28.61	12.01	23.37	21.94	24.69	17.84	26.75	11.23
4590	30	27.44	26.86	28.69	23.74	30.67	18.11	25.94	25.72	27.04	22.75	28.88	17.27	24.37	24.37	25.33	21.70	27.02	16.38
4590	33	28.65	28.65	29.53	27.13	31.15	22.79	27.15	27.15	27.89	26.04	29.36	21.85	25.58	25.58	26.17	24.88	27.50	20.85
5100	24	26.26	21.30	28.16	15.48	30.79	7.14	24.71	20.32	26.46	14.65	28.95	6.47	23.08	19.29	24.69	13.77	27.04	5.74
5100	27	27.13	24.87	28.66	20.34	30.92	13.29	25.58	23.79	26.96	19.41	29.08	12.51	23.95	22.64	25.19	18.42	27.17	11.68
5100	30	28.21	27.76	29.37	24.51	31.26	18.75	26.65	26.56	27.67	23.47	29.42	17.87	25.03	25.03	25.90	22.37	27.51	16.92
5100	33	29.49	29.49	30.28	28.00	31.81	23.53	27.94	27.94	28.59	26.85	29.97	22.54	26.31	26.31	26.82	25.64	28.06	21.48
5610	24	26.79	21.94	28.60	15.99	31.15	7.52	25.18	20.91	26.85	15.11	29.26	6.80	23.51	19.82	25.03	14.18	27.30	6.02
5610	27	27.73	25.60	29.18	20.94	31.36	13.77	26.13	24.46	27.43	19.96	29.47	12.94	24.45	23.27	25.61	18.92	27.50	12.05
5610	30	28.88	28.58	29.96	25.21	31.77	19.33	27.27	27.27	28.21	24.12	29.88	18.39	25.60	25.60	26.39	22.97	27.92	17.39
5610	33	30.23	30.23	30.95	28.79	32.39	24.20	28.63	28.63	29.20	27.59	30.50	23.15	26.95	26.95	27.38	26.33	28.54	22.04
6120	24	27.23	22.50	28.96	16.42	31.42	7.83	25.57	21.42	27.16	15.50	29.48	7.06	23.84	20.28	25.29	14.51	27.47	6.23
6120	27	28.24	26.26	29.60	21.47	31.70	14.17	26.59	25.07	27.81	20.44	29.76	13.29	24.86	23.82	25.93	19.34	27.75	12.35
6120	30	29.46	29.33	30.46	25.83	32.19	19.82	27.81	27.81	28.66	24.69	30.25	18.83	26.08	26.08	26.79	23.48	28.23	17.79
6120	33	30.89	30.89	31.52	29.50	32.88	24.79	29.24	29.24	29.72	28.25	30.94	23.69	27.51	27.51	27.85	26.94	28.93	22.53

m <sup>3</sup> /h Airflow		Ent DB (C)		Ambient Temperature											
				45						52					
				Entering Wet Bulb						Entering Wet Bulb					
				16	19	22		16	19	22		16	19	22	
TGC	SHC	TGC	SHC	TGC	SHC	TGC	SHC	TGC	SHC	TGC	SHC	TGC	SHC		
4080	24	20.37	17.01	22.01	11.90	24.37	4.27	18.71	15.95	20.20	11.00	22.42	3.53		
4080	27	21.10	20.07	22.36	16.25	24.36	9.91	19.43	18.90	20.55	15.24	22.41	9.06		
4080	30	22.03	22.03	22.93	19.91	24.56	14.87	20.36	20.36	21.12	18.79	22.61	13.91		
4080	33	23.17	23.17	23.70	22.88	24.96	19.13	21.67	21.67	21.89	21.66	23.01	18.06		
4590	24	20.92	17.64	22.47	12.40	24.76	4.65	19.20	16.53	20.61	11.45	22.75	3.86		
4590	27	21.72	20.79	22.90	16.84	24.82	10.38	20.00	19.57	21.04	15.78	22.81	9.48		
4590	30	22.72	22.72	23.54	20.60	25.09	15.43	21.00	21.00	21.68	19.43	23.08	14.42		
4590	33	23.93	23.93	24.38	23.66	25.57	19.79	22.30	22.30	22.52	22.39	23.56	18.67		
5100	24	21.39	18.19	22.85	12.83	25.05	4.96	19.62	17.03	20.94	11.83	23.00	4.11		
5100	27	22.25	21.43	23.35	17.36	25.19	10.78	20.48	20.17	21.44	16.25	23.13	9.83		
5100	30	23.33	23.33	24.06	21.21	25.53	15.92	21.56	21.56	22.15	19.99	23.47	14.86		
5100	33	24.61	24.61	24.98	24.37	26.08	20.37	22.84	22.84	23.07	23.05	24.02	19.20		
5610	24	21.76	18.67	23.14	13.18	25.26	5.19	19.94	17.46	21.18	12.13	23.15	4.29		
5610	27	22.70	22.01	23.72	17.81	25.47	11.10	20.88	20.69	21.75	16.65	23.36	10.10		
5610	30	23.85	23.85	24.50	21.75	25.88	16.34	22.03	22.03	22.54	20.48	23.78	15.22		
5610	33	25.23	25.23	25.49	25.01	26.51	20.88	23.53	23.53	23.53	23.53	24.40	19.66		
6120	24	22.04	19.08	23.34	13.46	25.38	5.34	20.17	17.81	21.33	12.36	23.22	4.39		
6120	27	23.06	22.51	23.99	18.19	25.66	11.35	21.19	21.14	21.98	16.97	23.50	10.30		
6120	30	24.28	24.28	24.85	22.22	26.15	16.68	22.41	22.41	22.83	20.90	23.99	15.51		
6120	33	25.65	25.65	25.91	25.57	26.84	21.32	23.90	23.90	23.90	23.90	24.69	20.04		

**Notes:**

1. All capacities shown are gross and have not considered indoor fan heat. To obtain **NET** cooling capacity subtract indoor fan heat. For indoor fan heat formula, refer to appropriate airflow table notes.
2. TGC = Total Gross Capacity
3. SHC = Sensible Heat Capacity



## Performance Data

**Table 6. Gross cooling capacities MBh 7½ tons standard efficiency – T/YSC090ED (IP)**

CFM Airflow		Ent DB (F)		Ambient Temperature															
				85				95				105							
				Entering Wet Bulb				Entering Wet Bulb				Entering Wet Bulb							
				61		67		73		61		67		73		61		67	
		TGC	SHC	TGC	SHC	TGC	SHC	TGC	SHC	TGC	SHC	TGC	SHC	TGC	SHC	TGC	SHC	TGC	SHC
2400	75	85.12	67.59	92.16	48.57	101.70	20.97	80.17	64.61	86.72	46.11	95.77	19.04	74.97	61.42	81.03	43.46	89.59	16.91
2400	80	87.58	79.14	93.37	64.52	101.66	41.32	82.63	75.79	87.92	61.69	95.73	39.03	77.43	72.23	82.24	58.67	89.55	36.53
2400	85	90.75	88.34	95.28	78.12	102.32	59.33	85.80	84.61	89.84	74.93	96.39	56.66	80.60	80.60	84.16	71.53	90.22	53.79
2400	90	94.63	94.63	97.91	89.38	103.69	74.99	89.68	89.68	92.47	85.81	97.77	71.95	84.49	84.49	86.79	82.04	91.60	68.71
2700	75	87.52	70.27	94.27	50.82	103.53	22.79	82.39	67.11	88.65	48.18	97.42	20.69	77.01	63.74	82.79	45.35	91.07	18.38
2700	80	90.23	82.13	95.73	67.08	103.73	43.46	85.10	78.60	90.11	64.08	97.63	40.99	79.73	74.87	84.25	60.88	91.28	38.31
2700	85	93.64	91.65	97.89	81.01	104.65	61.79	88.52	87.75	92.28	77.63	98.54	58.94	83.15	83.15	86.42	74.06	92.20	55.90
2700	90	97.77	97.77	100.77	92.58	106.27	77.76	92.65	92.65	95.16	88.84	100.17	74.55	87.28	87.28	89.30	84.89	93.82	71.13
3000	75	89.61	72.69	96.08	52.81	105.06	24.36	84.31	69.35	90.29	50.00	98.78	22.08	78.76	65.81	84.26	46.99	92.25	19.59
3000	80	92.57	84.87	97.79	69.40	105.51	45.35	87.27	81.16	92.00	66.22	99.23	42.70	81.72	77.25	85.96	62.84	92.71	39.84
3000	85	96.24	94.71	100.20	83.64	106.67	63.99	90.94	90.63	94.42	80.09	100.40	60.97	85.40	85.40	88.38	76.33	93.88	57.75
3000	90	100.62	100.62	103.33	95.53	108.55	80.29	95.32	95.32	97.54	91.61	102.27	76.90	89.78	89.78	91.51	87.49	95.75	73.30
3300	75	91.41	74.86	97.60	54.55	106.29	25.67	85.93	71.34	91.63	51.56	99.83	23.21	80.21	67.62	85.42	48.38	93.13	20.55
3300	80	94.62	87.36	99.55	71.46	106.99	46.98	89.14	83.47	93.59	68.10	100.54	44.15	83.42	79.38	87.38	64.54	93.84	41.12
3300	85	98.53	97.51	102.22	86.01	108.40	65.94	93.06	93.06	96.25	82.29	101.95	62.75	87.34	87.34	90.05	78.36	95.25	59.35
3300	90	103.16	103.16	105.59	98.22	110.52	82.56	97.69	97.69	99.63	94.13	104.07	78.99	91.97	91.97	93.42	89.83	97.38	75.22
3600	75	92.91	76.77	98.81	56.04	107.22	26.73	87.26	73.08	92.67	52.88	100.59	24.10	81.36	69.18	86.29	49.51	93.72	21.26
3600	80	96.36	89.59	101.01	73.26	108.17	48.36	90.71	85.53	94.88	69.73	101.54	45.36	84.82	81.26	88.49	65.99	94.67	42.15
3600	85	100.53	100.06	103.93	88.14	109.83	67.64	94.88	94.88	97.79	84.24	103.20	64.27	88.99	88.99	91.41	80.13	96.33	60.69
3600	90	105.41	105.41	107.55	100.67	112.20	84.57	99.76	99.76	101.42	96.39	105.58	80.83	93.87	93.87	95.04	91.92	98.71	76.88
CFM Airflow		Ent DB (F)		Ambient Temperature															
				115				125											
				Entering Wet Bulb				Entering Wet Bulb											
				61		67		73		61		67		73					
		TGC	SHC	TGC	SHC	TGC	SHC	TGC	SHC	TGC	SHC	TGC	SHC	TGC	SHC	TGC	SHC	TGC	SHC
2400	75	69.52	58.03	75.09	40.59	83.17	14.58	63.83	54.44	68.91	37.53	76.50	12.05						
2400	80	71.99	68.47	76.30	55.43	83.13	33.83	66.30	64.50	70.13	52.00	76.46	30.92						
2400	85	75.16	75.16	78.23	67.93	83.80	50.72	69.47	69.47	72.05	64.12	77.13	47.45						
2400	90	79.05	79.05	80.86	78.07	85.18	65.27	73.94	73.94	74.68	73.90	78.51	61.63						
2700	75	71.39	60.17	76.68	42.31	84.47	15.87	65.53	56.41	70.33	39.07	77.63	13.16						
2700	80	74.11	70.93	78.14	57.47	84.68	35.43	68.24	66.79	71.79	53.86	77.84	32.35						
2700	85	77.53	77.53	80.32	70.28	85.60	52.65	71.67	71.67	73.96	66.30	78.76	49.20						
2700	90	81.67	81.67	83.20	80.74	87.23	67.52	76.08	76.08	76.85	76.39	80.39	63.69						
3000	75	72.97	62.06	77.97	43.77	85.48	16.91	66.93	58.12	71.44	40.36	78.46	14.02						
3000	80	75.93	73.14	79.68	59.25	85.94	36.79	69.89	68.82	73.16	55.46	78.92	33.53						
3000	85	79.60	79.60	82.10	72.38	87.11	54.32	73.57	73.57	75.58	68.22	80.09	50.69						
3000	90	83.99	83.99	85.23	83.16	88.98	69.51	77.92	77.92	78.71	78.63	81.97	65.51						
3300	75	74.24	63.70	78.96	44.98	86.19	17.69	68.03	59.58	72.26	41.39	79.00	14.63						
3300	80	77.45	75.09	80.92	60.78	86.89	37.89	71.24	70.60	74.22	56.82	79.70	34.46						
3300	85	81.38	81.38	83.59	74.23	88.31	55.74	75.17	75.17	76.89	69.89	81.12	51.94						
3300	90	86.10	86.10	86.97	85.33	90.44	71.25	80.27	80.27	80.27	80.27	83.25	67.07						
3600	75	75.22	65.09	79.65	45.94	86.59	18.22	68.83	60.79	72.78	42.17	79.23	14.98						
3600	80	78.68	76.80	81.86	62.06	87.55	38.74	72.29	72.13	74.99	57.91	80.19	35.13						
3600	85	82.85	82.85	84.78	75.82	89.22	56.91	76.47	76.47	77.91	71.31	81.85	52.93						
3600	90	87.53	87.53	88.41	87.24	91.59	72.73	81.54	81.54	81.54	81.54	84.23	68.38						

**Notes:**

1. All capacities shown are gross and have not considered indoor fan heat. To obtain **NET** cooling capacity subtract indoor fan heat. For indoor fan heat formula, refer to appropriate airflow table notes.
2. TGC = Total Gross Capacity
3. SHC = Sensible Heat Capacity

**Table 7. Gross cooling capacities kw 8½ tons standard efficiency – T/YSC102ED (SI)**

m <sup>3</sup> /h Airflow		Ambient Temperature																	
		30						35						40					
		Entering Wet Bulb						Entering Wet Bulb						Entering Wet Bulb					
		Ent DB (C)	16	19	22	TGC	SHC	16	19	22	TGC	SHC	TGC	SHC	TGC	SHC	TGC	SHC	TGC
4620	24	28.83	22.79	31.23	16.57	34.47	7.58	26.86	21.52	29.09	15.48	32.16	6.66	24.76	20.15	26.82	14.28	29.72	5.64
4620	27	29.59	26.66	31.55	21.92	34.35	14.41	27.62	25.25	29.41	20.69	32.04	13.35	25.51	23.75	27.13	19.36	29.59	12.20
4620	30	30.59	29.73	32.11	26.48	34.47	20.45	28.61	28.19	29.96	25.11	32.15	19.26	26.50	26.50	27.68	23.64	29.70	17.96
4620	33	31.83	31.83	32.91	30.24	34.83	25.70	29.85	29.85	30.76	28.73	32.51	24.36	27.73	27.73	28.47	27.13	30.05	22.93
5200	24	29.64	23.77	31.93	17.40	35.07	8.25	27.61	22.43	29.73	16.24	32.70	7.27	25.44	21.01	27.39	14.98	30.19	6.19
5200	27	30.49	27.73	32.34	22.84	35.04	15.18	28.45	26.26	30.14	21.55	32.66	14.06	26.28	24.69	27.79	20.16	30.15	12.84
5200	30	31.58	30.90	32.99	27.49	35.25	21.31	29.54	29.29	30.78	26.06	32.87	20.06	27.36	27.36	28.43	24.53	30.35	18.70
5200	33	32.91	32.91	33.88	31.35	35.70	26.65	30.86	30.86	31.67	29.78	33.31	25.26	28.68	28.68	29.31	28.11	30.79	23.77
5780	24	30.36	24.62	32.55	18.09	35.57	8.80	28.26	23.22	30.28	16.88	33.13	7.76	26.02	21.74	27.87	15.56	30.56	6.62
5780	27	31.30	28.67	33.05	23.63	35.63	15.82	29.19	27.14	30.77	22.28	33.19	14.64	26.95	25.52	28.36	20.83	30.61	13.37
5780	30	32.48	31.94	33.79	28.38	35.93	22.05	30.37	30.27	31.51	26.89	33.49	20.73	28.12	28.12	29.09	25.30	30.90	19.32
5780	33	33.90	33.90	34.77	32.33	36.47	27.49	31.78	31.78	32.48	30.70	34.02	26.03	29.53	29.53	30.06	28.98	31.43	24.48
6360	24	30.99	25.34	33.07	18.67	35.99	9.22	28.82	23.89	30.73	17.39	33.48	8.12	26.51	22.34	28.26	16.02	30.84	6.92
6360	27	32.01	29.49	33.66	24.30	36.14	16.34	29.84	27.90	31.32	22.89	33.63	15.10	27.53	26.22	28.84	21.38	30.98	13.77
6360	30	33.28	32.85	34.49	29.14	36.53	22.66	31.11	31.11	32.14	27.59	34.01	21.29	28.79	28.79	29.66	25.95	31.36	19.82
6360	33	34.79	34.79	35.56	33.19	37.16	28.19	32.61	32.61	33.21	31.50	34.64	26.68	30.29	30.29	30.72	29.72	31.98	25.07
6940	24	31.52	25.94	33.49	19.12	36.31	9.52	29.28	24.43	31.09	17.78	33.73	8.36	26.91	22.82	28.55	16.35	31.02	7.10
6940	27	32.64	30.19	34.17	24.85	36.55	16.73	30.40	28.54	31.76	23.37	33.97	15.43	28.02	26.80	29.22	21.80	31.25	14.04
6940	30	34.00	33.64	35.09	29.78	37.03	23.15	31.75	31.75	32.68	28.17	34.44	21.72	29.37	29.37	30.13	26.47	31.72	20.19
6940	33	35.60	35.60	36.25	33.93	37.75	28.78	33.35	33.35	33.83	32.18	35.16	27.20	30.96	30.96	31.28	30.33	32.43	25.54
m <sup>3</sup> /h Airflow		Ambient Temperature																	
		45						52											
		Entering Wet Bulb						Entering Wet Bulb											
		Ent DB (C)	16	19	22	TGC	SHC	16	19	22	TGC	SHC	TGC	SHC	TGC	SHC	TGC	SHC	TGC
4620	24	22.52	18.69	24.41	12.99	27.15	4.53	20.14	17.13	21.87	11.61	24.43	3.32						
4620	27	23.26	22.15	24.72	17.93	27.01	10.95	20.88	20.45	22.17	16.42	24.29	9.61						
4620	30	24.25	24.25	25.27	22.08	27.12	16.58	21.86	21.86	22.71	20.42	24.39	15.10						
4620	33	25.47	25.47	26.05	25.43	27.46	21.41	23.49	23.49	23.49	23.49	24.73	19.79						
5200	24	23.13	19.48	24.92	13.64	27.54	5.02	20.68	17.87	22.30	12.20	24.76	3.75						
5200	27	23.96	23.04	25.31	18.67	27.50	11.54	21.51	21.28	22.69	17.09	24.71	10.13						
5200	30	25.04	25.04	25.95	22.91	27.69	17.26	22.58	22.58	23.33	21.20	24.90	15.72						
5200	33	26.56	26.56	26.82	26.36	28.13	22.19	24.20	24.20	24.20	24.20	25.33	20.51						
5780	24	23.64	20.15	25.33	14.16	27.85	5.38	21.13	18.48	22.65	12.65	25.00	4.06						
5780	27	24.57	23.80	25.81	19.29	27.89	12.00	22.05	21.99	23.13	17.65	25.04	10.53						
5780	30	25.74	25.74	26.54	23.62	28.18	17.82	23.21	23.21	23.85	21.85	25.32	16.22						
5780	33	27.23	27.23	27.50	27.16	28.70	22.84	24.81	24.81	24.81	24.81	25.84	21.10						
6360	24	24.07	20.70	25.64	14.55	28.06	5.63	21.49	18.96	22.90	12.99	25.14	4.24						
6360	27	25.08	24.44	26.22	19.77	28.19	12.34	22.50	22.50	23.47	18.08	25.27	10.81						
6360	30	26.34	26.34	27.04	24.21	28.57	18.25	23.75	23.75	24.28	22.37	25.64	16.59						
6360	33	27.81	27.81	28.09	27.84	29.18	23.37	25.33	25.33	25.33	25.33	26.25	21.57						
6940	24	24.40	21.12	25.87	14.82	28.18	5.75	21.75	19.32	23.05	13.20	25.19	4.30						
6940	27	25.50	24.96	26.53	20.14	28.40	12.55	22.85	22.85	23.71	18.38	25.41	10.97						
6940	30	26.85	26.85	27.44	24.67	28.87	18.56	24.19	24.19	24.61	22.77	25.87	16.84						
6940	33	28.30	28.30	28.58	28.40	29.57	23.77	25.75	25.75	25.75	25.75	26.57	21.92						

**Notes:**

1. All capacities shown are gross and have not considered indoor fan heat. To obtain **NET** cooling capacity subtract indoor fan heat. For indoor fan heat formula, refer to appropriate airflow table notes.
2. TGC = Total Gross Capacity
3. SHC = Sensible Heat Capacity



## Performance Data

**Table 8. Gross cooling capacities MBh 8½ tons standard efficiency—T/YSC102ED (IP)**

CFM Airflow		Ent DB (F)		Ambient Temperature															
				85				95				105							
				Entering Wet Bulb				Entering Wet Bulb				Entering Wet Bulb							
				61		67		73		61		67		73		61		67	
TGC		SHC		TGC		SHC		TGC		SHC		TGC		SHC		TGC		SHC	
2720	75	98.36	77.78	106.55	56.55	117.60	25.87	91.65	73.43	99.27	52.80	109.75	22.72	84.48	68.76	91.52	48.73	101.42	19.24
2720	80	100.95	90.97	107.64	74.81	117.19	49.18	94.23	86.16	100.35	70.59	109.32	45.56	87.04	81.02	92.58	66.05	100.98	41.62
2720	85	104.36	101.45	109.55	90.35	117.60	69.79	97.62	96.17	102.24	85.67	109.71	65.70	90.42	90.42	94.46	80.66	101.35	61.29
2720	90	108.59	108.59	112.28	103.18	118.83	87.68	101.84	101.84	104.95	98.03	110.92	83.13	94.61	94.61	97.15	92.56	102.55	78.25
3060	75	101.13	81.10	108.96	59.36	119.65	28.16	94.19	76.55	101.45	55.40	111.56	24.80	86.79	71.68	93.47	51.13	103.00	21.12
3060	80	104.03	94.62	110.36	77.94	119.55	51.80	97.08	89.60	102.83	73.52	111.44	47.97	89.66	84.26	94.83	68.77	102.87	43.83
3060	85	107.75	105.42	112.58	93.81	120.26	72.73	100.78	99.94	105.03	88.92	112.14	68.44	93.34	93.34	97.02	83.71	103.55	63.82
3060	90	112.29	112.29	115.61	106.96	121.80	90.94	105.30	105.30	108.05	101.61	113.66	86.19	97.84	97.84	100.02	95.93	105.06	81.11
3400	75	103.59	84.00	111.06	61.74	121.38	30.02	96.42	79.24	103.31	57.58	113.06	26.46	88.78	74.16	95.10	53.10	104.27	22.58
3400	80	106.79	97.84	112.76	80.64	121.58	53.99	99.61	92.62	105.00	76.02	113.25	49.96	91.96	87.07	96.77	71.07	104.44	45.61
3400	85	110.82	108.97	115.28	96.84	122.61	75.24	103.62	103.28	107.51	91.75	114.25	70.75	95.95	95.95	99.26	86.33	105.43	65.93
3400	90	115.66	115.66	118.63	110.32	124.45	93.79	108.44	108.44	110.83	104.76	116.08	88.82	100.76	100.76	102.57	98.88	107.24	83.54
3740	75	105.72	86.47	112.83	63.70	122.79	31.47	98.32	81.51	104.85	59.33	114.24	27.70	90.46	76.23	96.41	54.65	105.22	23.61
3740	80	109.24	100.64	114.84	82.93	123.30	55.76	101.82	95.21	106.85	78.10	114.74	51.52	93.94	89.46	98.39	72.95	105.70	46.97
3740	85	113.57	112.10	117.67	99.44	124.63	77.34	106.14	106.14	109.67	94.15	116.05	72.64	98.24	98.24	101.19	88.53	107.00	67.61
3740	90	118.72	118.72	121.32	113.25	126.78	96.20	111.27	111.27	113.30	107.49	118.18	91.04	103.36	103.36	104.81	101.40	109.12	85.55
4080	75	107.54	88.52	114.29	65.23	123.89	32.48	99.91	83.36	106.08	60.66	115.10	28.51	91.82	77.87	97.41	55.78	105.85	24.22
4080	80	111.37	103.01	116.61	84.79	124.70	57.10	103.72	97.38	108.38	79.75	115.91	52.66	95.60	91.43	99.69	74.40	106.64	47.90
4080	85	116.00	114.80	119.75	101.63	126.34	79.00	108.34	108.34	111.51	96.13	117.53	74.10	100.21	100.21	102.80	90.31	108.25	68.87
4080	90	121.46	121.46	123.70	115.76	128.80	98.20	113.78	113.78	115.45	109.79	119.97	92.83	105.64	105.64	106.72	103.50	110.67	87.13
CFM Airflow		Ent DB (F)		Ambient Temperature															
				115						125									
				Entering Wet Bulb						Entering Wet Bulb									
				61		67		73		61		67		73					
TGC		SHC		TGC		SHC		TGC		SHC		TGC		SHC					
2720	75	76.84	63.77	83.30	44.34	92.63	15.44	68.73	58.46	74.62	39.62	83.37	11.33						
2720	80	79.38	75.57	84.35	61.19	92.17	37.36	71.25	69.79	75.64	56.01	82.89	32.77						
2720	85	82.74	82.74	86.21	75.33	92.53	56.56	74.60	74.60	77.49	69.69	83.23	51.51						
2720	90	86.92	86.92	88.89	86.77	93.71	73.05	80.15	80.15	80.15	80.15	84.40	67.53						
3060	75	78.92	66.48	85.02	46.53	93.98	17.12	70.58	60.97	76.10	41.61	84.49	12.80						
3060	80	81.77	78.60	86.37	63.71	93.83	39.36	73.41	72.62	77.44	58.32	84.32	34.57						
3060	85	85.43	85.43	88.54	78.18	94.50	58.89	77.06	77.06	79.59	72.32	84.97	53.63						
3060	90	90.61	90.61	91.52	89.93	95.98	75.71	82.56	82.56	82.56	82.56	86.44	69.98						
3400	75	80.68	68.77	86.42	48.30	95.02	18.37	72.11	63.05	77.27	43.17	85.29	13.85						
3400	80	83.83	81.21	88.08	65.80	95.17	40.94	75.25	75.02	78.91	60.21	85.43	35.94						
3400	85	87.81	87.81	90.55	80.60	96.15	60.79	79.21	79.21	81.37	74.54	86.39	55.33						
3400	90	92.91	92.91	93.85	92.68	97.94	77.93	84.65	84.65	84.65	84.65	88.17	72.01						
3740	75	82.12	70.63	87.50	49.64	95.74	19.20	73.32	64.70	78.12	44.32	85.78	14.47						
3740	80	85.59	83.39	89.46	67.47	96.20	42.09	76.77	76.77	80.07	61.68	86.23	36.89						
3740	85	89.87	89.87	92.25	82.59	97.48	62.27	81.03	81.03	82.84	76.33	87.49	56.61						
3740	90	94.89	94.89	95.85	95.00	99.58	79.74	86.42	86.42	86.42	86.42	89.58	73.61						
4080	75	83.25	72.06	88.26	50.56	96.14	19.61	74.21	65.93	78.66	45.03	85.95	14.67						
4080	80	87.02	85.16	90.54	68.72	96.91	42.82	77.97	77.97	80.91	62.72	86.71	37.42						
4080	85	91.61	91.61	93.63	84.16	98.50	63.33	82.54	82.54	83.98	77.70	88.28	57.46						
4080	90	96.56	96.56	97.53	96.89	100.90	81.12	87.88	87.88	87.88	87.88	90.67	74.78						

**Notes:**

1. All capacities shown are gross and have not considered indoor fan heat. To obtain **NET** cooling capacity subtract indoor fan heat. For indoor fan heat formula, refer to appropriate airflow table notes.
2. TGC = Total Gross Capacity
3. SHC = Sensible Heat Capacity

**Table 9. Gross cooling capacities kw 10 tons standard efficiency—T/YSC120ED (SI)**

m <sup>3</sup> /h Airflow		Ent DB (C)		Ambient Temperature															
				30				35				40							
				Entering Wet Bulb				Entering Wet Bulb				Entering Wet Bulb							
				16	19	22		16	19	22		16	19	22		16	19	22	
TGC	SHC	TGC	SHC	TGC	SHC	TGC	SHC	TGC	SHC	TGC	SHC	TGC	SHC	TGC	SHC	TGC	SHC		
5440	24	32.76	26.95	35.31	20.04	38.77	9.85	30.65	25.53	33.00	18.78	36.27	8.76	28.41	24.01	30.57	17.42	33.64	7.56
5440	27	33.67	31.28	35.77	26.18	38.79	17.81	31.57	29.73	33.48	24.80	36.30	16.59	29.34	28.08	31.05	23.30	33.68	15.26
5440	30	34.83	34.67	36.48	31.39	39.05	24.84	32.73	32.73	34.20	29.87	36.57	23.48	30.51	30.51	31.78	28.25	33.96	22.02
5440	33	36.23	36.23	37.44	35.65	39.56	30.91	34.14	34.14	35.16	34.00	37.09	29.43	32.43	32.43	32.75	32.25	34.49	27.84
6120	24	33.60	27.88	36.01	20.79	39.33	10.42	31.42	26.40	33.64	19.47	36.77	9.27	29.11	24.82	31.14	18.05	34.07	8.01
6120	27	34.62	32.33	36.59	27.06	39.47	18.51	32.46	30.72	34.23	25.61	36.91	17.22	30.16	29.01	31.73	24.06	34.22	15.84
6120	30	35.89	35.84	37.41	32.38	39.85	25.65	33.74	33.74	35.06	30.81	37.30	24.24	31.45	31.45	32.58	29.12	34.62	22.72
6120	33	37.41	37.41	38.48	36.77	40.47	31.85	35.26	35.26	36.14	35.06	37.93	30.31	33.33	33.33	33.67	33.25	35.26	28.66
6800	24	34.33	28.74	36.61	21.46	39.79	10.92	32.09	27.20	34.17	20.09	37.16	9.71	29.72	25.55	31.60	18.61	34.40	8.39
6800	27	35.47	33.32	37.30	27.86	40.04	19.13	33.24	31.65	34.88	26.35	37.42	17.79	30.88	29.87	32.32	24.74	34.67	16.34
6800	30	36.86	36.86	38.24	33.31	40.54	26.40	34.64	34.64	35.83	31.67	37.93	24.93	32.29	32.29	33.28	29.93	35.18	23.35
6800	33	38.49	38.49	39.43	37.82	41.28	32.72	36.28	36.28	37.02	36.05	38.67	31.12	34.14	34.14	34.48	34.18	35.94	29.41
7480	24	34.97	29.53	37.10	22.07	40.15	11.35	32.66	27.93	34.60	20.64	37.46	10.08	30.22	26.22	31.97	19.10	34.63	8.70
7480	27	36.22	34.23	37.92	28.59	40.52	19.68	33.93	32.50	35.42	27.03	37.83	18.28	31.50	30.67	32.80	25.35	35.01	16.77
7480	30	37.73	37.73	38.97	34.17	41.13	27.08	35.44	35.44	36.49	32.47	38.45	25.54	33.02	33.02	33.88	30.67	35.64	23.91
7480	33	39.47	39.47	40.27	38.80	41.98	33.53	37.20	37.20	37.80	36.98	39.32	31.86	34.84	34.84	35.20	35.04	36.52	30.10
8160	24	35.50	30.25	37.50	22.61	40.41	11.71	33.13	28.59	34.93	21.12	37.65	10.38	30.63	26.82	32.24	19.52	34.76	8.94
8160	27	36.87	35.07	38.43	29.26	40.89	20.17	34.51	33.28	35.87	27.63	38.14	18.70	32.02	31.39	33.18	25.90	35.26	17.14
8160	30	38.49	38.49	39.60	34.96	41.62	27.68	36.14	36.14	37.05	33.20	38.88	26.09	33.65	33.65	34.37	31.34	36.00	24.39
8160	33	40.35	40.35	41.02	39.71	42.59	34.26	38.01	38.01	38.48	37.83	39.86	32.54	35.81	35.81	35.81	35.81	36.99	30.71
m <sup>3</sup> /h Airflow		Ent DB (C)		Ambient Temperature															
				45						52									
				Entering Wet Bulb						Entering Wet Bulb									
				16	19	22		16	19	22		16	19	22					
TGC	SHC	TGC	SHC	TGC	SHC	TGC	SHC	TGC	SHC	TGC	SHC	TGC	SHC						
5440	24	26.03	22.38	28.00	15.95	30.87	6.26	23.53	20.64	25.30	14.38	27.98	4.85						
5440	27	26.97	26.31	28.49	21.71	30.92	13.83	24.48	24.45	25.80	20.00	28.04	12.29						
5440	30	28.16	28.16	29.23	26.52	31.21	20.46	25.67	25.67	26.55	24.69	28.34	18.79						
5440	33	30.21	30.21	30.21	30.21	31.75	26.15	27.54	27.54	27.54	27.54	28.89	24.35						
6120	24	26.68	23.12	28.50	16.52	31.24	6.64	24.11	21.33	25.74	14.89	28.28	5.17						
6120	27	27.73	27.19	29.11	22.40	31.40	14.34	25.17	25.17	26.36	20.64	28.45	12.74						
6120	30	29.03	29.03	29.97	27.34	31.81	21.10	26.48	26.48	27.22	25.44	28.87	19.37						
6120	33	31.06	31.06	31.06	31.06	32.46	26.91	28.33	28.33	28.33	28.33	29.53	25.05						
6800	24	27.22	23.80	28.91	17.02	31.51	6.96	24.58	21.95	26.08	15.32	28.48	5.43						
6800	27	28.39	27.99	29.63	23.02	31.78	14.78	25.76	25.76	26.81	21.20	28.77	13.12						
6800	30	29.80	29.80	30.60	28.08	32.31	21.66	27.19	27.19	27.79	26.13	29.30	19.87						
6800	33	31.81	31.81	31.81	31.81	33.08	27.60	29.01	29.01	29.01	29.01	30.08	25.68						
7480	24	27.65	24.41	29.21	17.45	31.67	7.21	24.96	22.50	26.31	15.69	28.58	5.62						
7480	27	28.94	28.72	30.05	23.58	32.06	15.16	26.25	26.25	27.16	21.69	28.98	13.44						
7480	30	30.47	30.47	31.13	28.76	32.70	22.16	27.79	27.79	28.26	26.75	29.63	20.31						
7480	33	32.46	32.46	32.46	32.46	33.59	28.22	29.59	29.59	29.59	29.59	30.53	26.24						
8160	24	27.99	24.95	29.41	17.81	31.73	7.39	25.23	22.98	26.45	15.99	28.58	5.74						
8160	27	29.39	29.39	30.36	24.06	32.24	15.46	26.64	26.64	27.41	22.12	29.10	13.68						
8160	30	31.04	31.04	31.56	29.37	33.00	22.59	28.29	28.29	28.62	27.30	29.86	20.68						
8160	33	33.01	33.01	33.01	33.01	34.00	28.78	30.08	30.08	30.08	30.08	30.87	26.74						

**Notes:**

1. All capacities shown are gross and have not considered indoor fan heat. To obtain **NET** cooling capacity subtract indoor fan heat. For indoor fan heat formula, refer to appropriate airflow table notes.
2. TGC = Total Gross Capacity
3. SHC = Sensible Heat Capacity



## Performance Data

**Table 10. Gross cooling capacities MBh 10 tons standard efficiency—T/YSC120ED (IP)**

CFM Airflow		Ent DB (F)		Ambient Temperature															
				85				95				105							
				Entering Wet Bulb				Entering Wet Bulb				Entering Wet Bulb							
				61		67		73		61		67		73		61		67	
TGC		SHC		TGC		SHC		TGC		SHC		TGC		SHC		TGC		SHC	
3200	75	111.77	91.97	120.47	68.37	132.28	33.62	104.57	87.12	112.61	64.09	123.75	29.89	96.93	81.92	104.30	59.44	114.77	25.80
3200	80	114.88	106.74	122.06	89.34	132.35	60.79	107.72	101.45	114.23	84.61	123.85	56.61	100.10	95.80	105.95	79.52	114.90	52.08
3200	85	118.83	118.29	124.48	107.09	133.25	84.74	111.69	111.69	116.68	101.92	124.78	80.12	104.11	104.11	108.43	96.39	115.87	75.15
3200	90	123.61	123.61	127.74	121.63	134.99	105.48	116.50	116.50	119.97	116.02	126.55	100.42	110.64	110.64	111.76	110.04	117.67	95.00
3600	75	114.63	95.13	122.86	70.92	134.20	35.56	107.21	90.08	114.77	66.43	125.45	31.62	99.34	84.67	106.24	61.58	116.25	27.33
3600	80	118.13	110.32	124.84	92.31	134.66	63.15	110.74	104.83	116.79	87.38	125.94	58.77	102.91	98.98	108.28	82.08	116.77	54.03
3600	85	122.47	122.30	127.66	110.49	135.96	87.52	115.11	115.11	119.64	105.12	127.27	82.70	107.31	107.31	111.16	99.38	118.13	77.52
3600	90	127.65	127.65	131.31	125.46	138.09	108.69	120.32	120.32	123.32	119.64	129.43	103.42	113.73	113.73	114.88	113.45	120.32	97.80
4000	75	117.14	98.06	124.90	73.24	135.78	37.26	109.50	92.81	116.59	68.54	126.80	33.12	101.40	87.19	107.83	63.49	117.37	28.62
4000	80	121.04	113.68	127.28	95.05	136.63	65.27	113.43	107.98	119.00	89.92	127.68	60.69	105.37	101.92	110.27	84.42	118.29	55.75
4000	85	125.77	125.77	130.49	113.66	138.32	90.07	118.19	118.19	122.24	108.07	129.41	85.05	110.16	110.16	113.55	102.13	120.05	79.66
4000	90	131.34	131.34	134.54	129.04	140.84	111.66	123.79	123.79	126.32	123.02	131.96	106.19	116.48	116.48	117.66	116.63	122.63	100.36
4400	75	119.31	100.75	126.60	75.32	137.00	38.72	111.44	95.30	118.07	70.42	127.80	34.38	103.12	89.48	109.08	65.16	118.16	29.67
4400	80	123.60	116.79	129.37	97.56	138.25	67.16	115.76	110.89	120.87	92.21	129.08	62.37	107.48	104.63	111.92	86.51	119.47	57.23
4400	85	128.73	128.73	132.98	116.58	140.34	92.38	120.92	120.92	124.51	110.80	131.20	87.16	112.67	112.67	115.59	104.65	121.62	81.57
4400	90	134.69	134.69	137.42	132.40	143.25	114.40	126.92	126.92	128.98	126.17	134.15	108.73	118.89	118.89	120.09	119.58	124.60	102.69
4800	75	121.13	103.21	127.95	77.16	137.89	39.95	113.04	97.55	119.20	72.05	128.46	35.40	104.50	91.53	109.99	66.59	118.59	30.49
4800	80	125.81	119.68	131.12	99.82	139.53	68.81	117.75	113.57	122.39	94.28	130.14	63.82	109.25	107.11	113.22	88.37	120.30	58.47
4800	85	131.33	131.33	135.12	119.27	142.01	94.46	123.31	123.31	126.42	113.28	132.65	89.03	114.83	114.83	117.28	106.93	122.84	83.24
4800	90	137.69	137.69	139.95	135.51	145.32	116.90	129.70	129.70	131.29	129.08	135.99	111.02	122.18	122.18	122.18	122.18	126.22	104.78
CFM Airflow		Ent DB (F)		Ambient Temperature															
				115				125											
				Entering Wet Bulb				Entering Wet Bulb											
				61		67		73		61		67		73					
TGC		SHC		TGC		SHC		TGC		SHC		TGC		SHC					
3200	75	88.83	76.35	95.54	54.43	105.35	21.35	80.29	70.42	86.33	49.06	95.47	16.53						
3200	80	92.04	89.79	97.22	74.07	105.51	47.18	83.53	83.42	88.04	68.25	95.67	41.93						
3200	85	96.08	96.08	99.74	90.49	106.51	69.81	87.60	87.60	90.60	84.23	96.70	64.11						
3200	90	103.09	103.09	103.09	103.09	108.34	89.22	93.98	93.98	93.98	93.98	98.56	83.08						
3600	75	91.02	78.90	97.25	56.37	106.60	22.67	82.26	72.77	87.82	50.79	96.50	17.65						
3600	80	94.62	92.76	99.33	76.43	107.15	48.93	85.89	85.89	89.93	70.41	97.09	43.47						
3600	85	99.06	99.06	102.25	93.28	108.55	71.98	90.36	90.36	92.88	86.81	98.51	66.08						
3600	90	106.00	106.00	106.00	106.00	110.77	91.81	96.66	96.66	96.66	96.66	100.77	85.47						
4000	75	92.86	81.22	98.63	58.07	107.50	23.76	83.88	74.88	88.97	52.29	97.18	18.54						
4000	80	96.86	95.50	101.10	78.55	108.45	50.44	87.90	87.90	91.48	72.33	98.16	44.78						
4000	85	101.69	101.69	104.41	95.83	110.24	73.92	92.76	92.76	94.82	89.16	99.98	67.81						
4000	90	108.55	108.55	108.55	108.55	112.86	94.17	98.99	98.99	98.99	98.99	102.64	87.62						
4400	75	94.36	83.30	99.66	59.53	108.06	24.61	85.15	76.76	89.78	53.55	97.52	19.18						
4400	80	98.75	98.01	102.52	80.44	109.41	51.72	89.57	89.57	92.68	74.02	98.89	45.85						
4400	85	103.97	103.97	106.22	98.14	111.59	75.62	94.83	94.83	96.41	91.27	101.11	69.30						
4400	90	110.76	110.76	110.76	110.76	114.60	96.30	100.98	100.98	100.98	100.98	104.16	89.54						
4800	75	95.51	85.14	100.34	60.76	108.27	25.23	86.08	78.40	90.24	54.58	97.51	19.60						
4800	80	100.29	100.28	103.60	82.10	110.01	52.76	90.89	90.89	93.53	75.47	99.28	46.69						
4800	85	105.91	105.91	107.69	100.22	112.59	77.08	96.54	96.54	97.66	93.15	101.89	70.56						
4800	90	112.63	112.63	112.63	112.63	116.00	98.19	102.62	102.62	102.62	102.62	105.33	91.23						

**Notes:**

1. All capacities shown are gross and have not considered indoor fan heat. To obtain **NET** cooling capacity subtract indoor fan heat. For indoor fan heat formula, refer to appropriate airflow table notes.
2. TGC = Total Gross Capacity
3. SHC = Sensible Heat Capacity



**Table 11. Gross cooling capacities kw 5 tons standard efficiency—WSC060ED (SI)**

m <sup>3</sup> /h Airflow		Ambient Temperature																	
		30						35						40					
		Entering Wet Bulb						Entering Wet Bulb						Entering Wet Bulb					
		16	19	22	TGC	SHC		16	19	22	TGC	SHC		16	19	22	TGC	SHC	
Ent DB (C)	TGC	SHC	TGC	SHC	TGC	SHC	TGC	SHC	TGC	SHC	TGC	SHC	TGC	SHC	TGC	SHC	TGC	SHC	
2720	24	16.41	13.61	17.56	10.11	19.06	4.71	15.28	12.88	16.42	9.60	17.90	4.41	14.01	12.03	15.14	8.97	16.61	4.00
2720	27	16.95	15.73	17.89	12.96	19.18	8.28	15.85	14.97	16.78	12.41	18.05	7.95	14.61	14.09	15.53	11.75	16.78	7.50
2720	30	17.63	17.42	18.36	15.37	19.43	11.42	16.56	16.56	17.28	14.80	18.33	11.06	15.36	15.36	16.06	14.10	17.10	10.58
2720	33	18.45	18.45	18.97	17.35	19.84	14.12	17.41	17.41	17.92	16.74	18.77	13.73	16.24	16.24	16.73	16.02	17.56	13.22
3060	24	16.89	14.03	17.97	10.43	19.39	4.92	15.76	13.30	16.82	9.91	18.22	4.62	14.50	12.45	15.54	9.28	16.93	4.20
3060	27	17.46	16.24	18.33	13.35	19.54	8.57	16.36	15.47	17.22	12.81	18.41	8.24	15.13	14.59	15.97	12.14	17.14	7.79
3060	30	18.18	18.00	18.84	15.85	19.83	11.79	17.11	17.11	17.75	15.27	18.73	11.42	15.91	15.91	16.53	14.57	17.50	10.94
3060	33	19.04	19.04	19.49	17.91	20.27	14.57	18.00	18.00	18.43	17.29	19.20	14.17	16.83	16.83	17.24	16.56	17.99	13.66
3400	24	17.30	14.41	18.30	10.70	19.64	5.08	16.17	13.67	17.15	10.18	18.48	4.78	14.91	12.82	15.87	9.54	17.18	4.36
3400	27	17.91	16.69	18.70	13.70	19.83	8.81	16.81	15.92	17.58	13.15	18.70	8.48	15.58	15.04	16.33	12.48	17.43	8.02
3400	30	18.67	18.53	19.24	16.27	20.16	12.11	17.60	17.60	18.16	15.69	19.06	11.74	16.39	16.39	16.94	14.99	17.82	11.25
3400	33	19.56	19.56	19.93	18.41	20.63	14.97	18.52	18.52	18.87	17.79	19.56	14.56	17.35	17.35	17.68	17.06	18.35	14.05
3740	24	17.64	14.73	18.56	10.92	19.82	5.20	16.51	14.00	17.42	10.40	18.66	4.89	15.24	13.14	16.13	9.76	17.36	4.47
3740	27	18.29	17.09	19.00	14.00	20.04	9.00	17.19	16.32	17.88	13.44	18.91	8.66	15.95	15.44	16.63	12.77	17.65	8.21
3740	30	19.08	19.01	19.58	16.65	20.41	12.37	18.01	18.01	18.49	16.06	19.31	12.00	16.80	16.80	17.27	15.36	18.07	11.51
3740	33	20.01	20.01	20.30	18.86	20.92	15.31	18.97	18.97	19.24	18.24	19.85	14.91	17.87	17.87	18.05	17.50	18.64	14.39
4080	24	17.91	15.01	18.75	11.09	19.93	5.26	16.78	14.27	17.61	10.56	18.77	4.95	15.51	13.41	16.32	9.92	17.47	4.53
4080	27	18.59	17.44	19.22	14.25	20.19	9.14	17.49	16.67	18.11	13.69	19.06	8.80	16.26	15.78	16.85	13.02	17.79	8.35
4080	30	19.42	19.42	19.84	16.97	20.59	12.59	18.35	18.35	18.75	16.38	19.49	12.22	17.14	17.14	17.53	15.68	18.25	11.73
4080	33	20.39	20.39	20.59	19.26	21.14	15.61	19.35	19.35	19.54	18.64	20.07	15.20	18.16	18.16	18.34	17.90	18.86	14.68
m <sup>3</sup> /h Airflow		Ambient Temperature																	
		45									52								
		Entering Wet Bulb									Entering Wet Bulb								
		16	19	22	TGC	SHC		16	19	22	TGC	SHC		16	19	22	TGC	SHC	
Ent DB (C)	TGC	SHC	TGC	SHC	TGC	SHC	TGC	SHC	TGC	SHC	TGC	SHC	TGC	SHC	TGC	SHC	TGC	SHC	
2720	24	12.62	11.07	13.73	8.22	15.18	3.46	11.08	9.99	12.18	7.35	13.61	2.81						
2720	27	13.24	13.10	14.14	10.97	15.38	6.94	11.74	11.74	12.63	10.07	13.85	6.25						
2720	30	14.02	14.02	14.70	13.29	15.73	9.98	12.54	12.54	13.22	12.36	14.23	9.26						
2720	33	15.25	15.25	15.41	15.17	16.22	12.59	13.95	13.95	13.95	13.95	14.75	11.84						
3060	24	13.10	11.49	14.13	8.53	15.50	3.67	11.56	10.40	12.58	7.66	13.93	3.01						
3060	27	13.76	13.59	14.58	11.36	15.74	7.22	12.26	12.26	13.06	10.46	14.21	6.53						
3060	30	14.57	14.57	15.18	13.75	16.12	10.34	13.10	13.10	13.69	12.82	14.62	9.62						
3060	33	15.76	15.76	15.92	15.71	16.65	13.02	14.46	14.46	14.46	14.46	15.18	12.27						
3400	24	13.51	11.86	14.46	8.79	15.75	3.82	11.97	10.77	12.91	7.92	14.19	3.17						
3400	27	14.21	14.04	14.95	11.70	16.03	7.45	12.70	12.70	13.43	10.79	14.49	6.76						
3400	30	15.05	15.05	15.58	14.17	16.45	10.65	13.58	13.58	14.09	13.23	14.94	9.93						
3400	33	16.19	16.19	16.35	16.21	17.01	13.41	14.89	14.89	14.89	14.89	15.53	12.66						
3740	24	13.84	12.17	14.72	9.00	15.93	3.93	12.31	11.08	13.17	8.13	14.37	3.27						
3740	27	14.58	14.43	15.24	11.99	16.24	7.64	13.08	13.08	13.72	11.08	14.71	6.94						
3740	30	15.46	15.46	15.91	14.53	16.70	10.91	13.99	13.99	14.42	13.60	15.19	10.19						
3740	33	16.55	16.55	16.72	16.65	17.30	13.75	15.26	15.26	15.26	15.26	15.82	12.99						
4080	24	14.11	12.44	14.91	9.16	16.04	3.98	12.58	11.35	13.36	8.29	14.47	3.32						
4080	27	14.88	14.78	15.47	12.23	16.39	7.77	13.38	13.38	13.95	11.32	14.85	7.08						
4080	30	15.80	15.80	16.17	14.85	16.88	11.12	14.32	14.32	14.68	13.91	15.37	10.39						
4080	33	17.02	17.02	17.02	17.02	17.52	14.04	15.56	15.56	15.56	15.56	16.04	13.28						

**Notes:**

1. All capacities shown are gross and have not considered indoor fan heat. To obtain **NET** cooling capacity subtract indoor fan heat. For indoor fan heat formula, refer to appropriate airflow table notes.
2. TGC = Total Gross Capacity
3. SHC = Sensible Heat Capacity



## Performance Data

**Table 12. Gross cooling capacities MBh 5 tons standard efficiency—WSC060ED (IP)**

CFM Airflow		Ent DB (F)		Ambient Temperature															
				85				95				105							
				Entering Wet Bulb				Entering Wet Bulb				Entering Wet Bulb							
				61		67		73		61		67		73		61		67	
		TGC	SHC	TGC	SHC	TGC	SHC	TGC	SHC	TGC	SHC	TGC	SHC	TGC	SHC	TGC	SHC	TGC	SHC
1600	75	55.98	46.43	59.93	34.50	65.04	16.07	52.13	43.95	56.02	32.75	61.08	15.05	47.81	41.06	51.66	30.60	56.66	13.63
1600	80	57.82	53.68	61.05	44.22	65.43	28.26	54.07	51.09	57.25	42.36	61.58	27.13	49.86	48.09	52.98	40.09	57.26	25.60
1600	85	60.15	59.45	62.65	52.46	66.31	38.97	56.50	56.50	58.95	50.48	62.56	37.73	52.39	52.39	54.79	48.11	58.35	36.09
1600	90	62.96	62.96	64.74	59.22	67.68	48.20	59.42	59.42	61.15	57.13	64.03	46.85	55.41	55.41	57.09	54.65	59.92	45.10
1800	75	57.62	47.88	61.31	35.58	66.14	16.79	53.77	45.39	57.40	33.82	62.18	15.77	49.46	42.49	53.03	31.66	57.77	14.34
1800	80	59.59	55.40	62.55	45.57	66.66	29.24	55.84	52.79	58.74	43.70	62.81	28.11	51.63	49.79	54.48	41.43	58.49	26.57
1800	85	62.04	61.43	64.28	54.07	67.67	40.22	58.39	58.39	60.57	52.09	63.91	38.97	54.28	54.28	56.41	49.71	59.70	37.32
1800	90	64.98	64.98	66.49	61.10	69.16	49.71	61.43	61.43	62.89	59.00	65.50	48.36	57.42	57.42	58.83	56.51	61.39	46.60
2000	75	59.03	49.16	62.44	36.50	67.01	17.35	55.17	46.66	58.53	34.73	63.05	16.31	50.86	43.76	54.17	32.56	58.63	14.88
2000	80	61.12	56.94	63.81	46.75	67.65	30.07	57.36	54.33	60.00	44.87	63.79	28.92	53.15	51.31	55.73	42.59	59.47	27.38
2000	85	63.69	63.24	65.66	55.52	68.78	41.30	60.04	60.04	61.95	53.53	65.02	40.05	55.93	55.93	57.79	51.14	60.80	38.39
2000	90	66.75	66.75	67.99	62.81	70.39	51.06	63.20	63.20	64.39	60.71	66.73	49.70	59.19	59.19	60.33	58.20	62.62	47.93
2200	75	60.19	50.27	63.33	37.25	67.63	17.73	56.33	47.76	59.42	35.47	63.67	16.69	52.02	44.85	55.05	33.30	59.24	15.25
2200	80	62.40	58.32	64.82	47.76	68.40	30.72	58.65	55.69	61.01	45.88	64.53	29.56	54.43	52.67	56.74	43.59	60.21	28.01
2200	85	65.10	64.88	66.79	56.80	69.64	42.22	61.44	61.44	63.09	54.80	65.88	40.96	57.33	57.33	58.92	52.40	61.66	39.29
2200	90	68.28	68.28	69.25	64.35	71.38	52.25	64.73	64.73	65.65	62.24	67.72	50.87	60.96	60.96	61.58	59.73	63.60	49.09
2400	75	61.11	51.21	63.98	37.83	68.01	17.95	57.25	48.69	60.07	36.04	64.05	16.90	52.93	45.77	55.70	33.86	59.62	15.45
2400	80	63.44	59.52	65.59	48.61	68.90	31.20	59.68	56.89	61.78	46.71	65.03	30.04	55.47	53.86	57.51	44.41	60.71	28.47
2400	85	66.26	66.26	67.69	57.91	70.27	42.97	62.60	62.60	63.98	55.90	66.51	41.70	58.49	58.49	59.81	53.49	62.28	40.02
2400	90	69.56	69.56	70.27	65.72	72.12	53.26	66.01	66.01	66.66	63.60	68.46	51.87	61.97	61.97	62.59	61.08	64.34	50.09
CFM Airflow		Ent DB (F)		Ambient Temperature															
				115				125											
				Entering Wet Bulb				Entering Wet Bulb											
				61		67		73		61		67		73					
		TGC	SHC	TGC	SHC	TGC	SHC	TGC	SHC	TGC	SHC	TGC	SHC	TGC	SHC	TGC	SHC	TGC	SHC
1600	75	43.04	37.78	46.84	28.04	51.78	11.82	37.81	34.09	41.55	25.09	46.44	9.60						
1600	80	45.19	44.69	48.26	37.43	52.48	23.67	40.06	40.06	43.08	34.37	47.25	21.34						
1600	85	47.83	47.83	50.17	45.34	53.67	34.05	42.80	42.80	45.09	42.16	48.54	31.61						
1600	90	52.04	52.04	52.57	51.76	55.35	42.94	47.59	47.59	47.59	47.59	50.31	40.39						
1800	75	44.69	39.20	48.21	29.10	52.89	12.51	39.45	35.50	42.92	26.14	47.55	10.29						
1800	80	46.96	46.38	49.76	38.75	53.71	24.63	41.82	41.82	44.57	35.68	48.47	22.30						
1800	85	49.71	49.71	51.79	46.92	55.02	35.27	44.68	44.68	46.71	43.74	49.88	32.82						
1800	90	53.76	53.76	54.31	53.61	56.81	44.43	49.33	49.33	49.33	49.33	51.78	41.87						
2000	75	46.08	40.45	49.34	29.99	53.74	13.04	40.85	36.75	44.05	27.02	48.40	10.81						
2000	80	48.48	47.90	51.01	39.91	54.69	25.43	43.34	43.34	45.82	36.83	49.45	23.08						
2000	85	51.36	51.36	53.16	48.34	56.12	36.33	46.32	46.32	48.08	45.15	50.98	33.87						
2000	90	55.25	55.25	55.80	55.30	58.04	45.76	50.82	50.82	50.82	50.82	53.00	43.19						
2200	75	47.24	41.53	50.22	30.72	54.36	13.40	42.00	37.82	44.93	27.74	49.02	11.16						
2200	80	49.75	49.24	52.01	40.90	55.43	26.05	44.62	44.62	46.83	37.80	50.19	23.70						
2200	85	52.76	52.76	54.29	49.59	56.98	37.22	47.72	47.72	49.21	46.39	51.84	34.75						
2200	90	56.49	56.49	57.06	56.81	59.02	46.91	52.07	52.07	52.07	52.07	53.99	44.33						
2400	75	48.15	42.45	50.86	31.27	54.73	13.60	42.91	38.73	45.57	28.28	49.39	11.34						
2400	80	50.79	50.42	52.78	41.71	55.92	26.51	45.65	45.65	47.59	38.61	50.68	24.14						
2400	85	53.91	53.91	55.18	50.68	57.60	37.94	48.88	48.88	50.09	47.46	52.46	35.47						
2400	90	58.06	58.06	58.06	58.06	59.76	47.90	53.08	53.08	53.08	53.08	54.72	45.31						

**Notes:**

1. All capacities shown are gross and have not considered indoor fan heat. To obtain **NET** cooling capacity subtract indoor fan heat. For indoor fan heat formula, refer to appropriate airflow table notes.
2. TGC = Total Gross Capacity
3. SHC = Sensible Heat Capacity

**Table 13. Gross cooling capacities kw 6 tons standard efficiency—WSC072ED (SI)**

m <sup>3</sup> /h Airflow		Ambient Temperature																	
		30						35						40					
		Entering Wet Bulb						Entering Wet Bulb						Entering Wet Bulb					
		16	19	22	16	19	22	16	19	22	16	19	22	16	19	22	16	19	22
Ent DB (C)	TGC	SHC	TGC	SHC	TGC	SHC	TGC	SHC	TGC	SHC	TGC	SHC	TGC	SHC	TGC	SHC	TGC	SHC	
3260	24	22.17	17.42	23.20	12.94	24.40	6.45	21.00	16.58	22.09	12.32	23.36	6.04	19.53	15.52	20.69	11.47	22.03	5.41
3260	27	22.77	20.18	23.60	16.57	24.61	10.95	21.66	19.39	22.56	16.00	23.63	10.60	20.25	18.38	21.22	15.21	22.36	10.02
3260	30	23.48	22.30	24.12	19.57	24.94	14.82	22.43	21.56	23.14	19.04	24.02	14.52	21.09	20.60	21.87	18.30	22.81	14.00
3260	33	24.32	23.78	24.77	21.93	25.39	18.06	23.33	23.09	23.85	21.46	24.53	17.81	22.05	22.05	22.63	20.77	23.39	17.34
3670	24	22.69	17.97	23.62	13.38	24.71	6.77	21.57	17.15	22.56	12.78	23.72	6.39	20.15	16.11	21.20	11.96	22.43	5.78
3670	27	23.32	20.78	24.05	17.06	24.95	11.33	22.25	20.01	23.05	16.51	24.02	11.00	20.90	19.02	21.76	15.74	22.80	10.44
3670	30	24.06	22.95	24.60	20.11	25.31	15.26	23.06	22.23	23.67	19.61	24.44	14.97	21.77	21.30	22.44	18.89	23.28	14.47
3670	33	24.93	24.49	25.27	22.52	25.79	18.55	23.99	23.82	24.40	22.08	24.99	18.31	22.76	22.76	23.23	21.41	23.88	17.87
4080	24	23.11	18.44	23.93	13.74	24.93	7.02	22.04	17.64	22.92	13.16	23.98	6.65	20.66	16.63	21.62	12.36	22.74	6.07
4080	27	23.77	21.30	24.39	17.47	25.20	11.63	22.75	20.55	23.45	16.94	24.31	11.32	21.44	19.59	22.20	16.19	23.13	10.79
4080	30	24.54	23.52	24.98	20.57	25.59	15.61	23.59	22.83	24.09	20.09	24.76	15.34	22.34	21.92	22.91	19.40	23.65	14.87
4080	33	25.44	25.12	25.68	23.04	26.09	18.95	24.55	24.47	24.86	22.61	25.34	18.74	23.36	23.36	23.74	21.97	24.28	18.31
4490	24	23.43	18.83	24.15	14.01	25.04	7.18	22.40	18.05	23.19	13.45	24.14	6.84	21.08	17.06	21.93	12.67	22.95	6.28
4490	27	24.12	21.74	24.64	17.80	25.34	11.84	23.15	21.02	23.74	17.29	24.50	11.55	21.89	20.07	22.55	16.57	23.37	11.05
4490	30	24.92	24.02	25.25	20.95	25.76	15.87	24.02	23.34	24.42	20.50	24.99	15.64	22.82	22.45	23.28	19.82	23.92	15.18
4490	33	25.85	25.66	25.99	23.47	26.30	19.27	25.01	25.01	25.21	23.07	25.59	19.08	23.87	23.87	24.14	22.45	24.58	18.68
4900	24	23.65	19.13	24.27	14.20	25.05	7.26	22.67	18.38	23.35	13.67	24.20	6.94	21.40	17.41	22.14	12.91	23.06	6.40
4900	27	24.37	22.10	24.79	18.04	25.38	11.98	23.45	21.39	23.94	17.56	24.60	11.71	22.24	20.47	22.79	16.86	23.51	11.22
4900	30	25.20	24.43	25.43	21.25	25.83	16.06	24.35	23.78	24.64	20.82	25.11	15.84	23.20	22.91	23.55	20.17	24.09	15.41
4900	33	26.16	26.13	26.20	23.82	26.40	19.51	25.36	25.36	25.47	23.44	25.74	19.34	24.28	24.28	24.44	22.84	24.78	18.96
m <sup>3</sup> /h Airflow		Ambient Temperature																	
		45						52											
		Entering Wet Bulb						Entering Wet Bulb											
		16	19	22	16	19	22	16	19	22	16	19	22	16	19	22	16	19	22
Ent DB (C)	TGC	SHC	TGC	SHC	TGC	SHC	TGC	SHC	TGC	SHC	TGC	SHC	TGC	SHC	TGC	SHC	TGC	SHC	
3260	24	17.77	14.24	19.00	10.41	20.40	4.57	15.72	12.74	17.01	9.13	18.47	3.51						
3260	27	18.56	17.15	19.59	14.20	20.79	9.23	16.56	15.70	17.66	12.97	18.93	8.22						
3260	30	19.46	19.42	20.30	17.35	21.31	13.25	17.53	17.53	18.43	16.17	19.51	12.29						
3260	33	20.48	20.48	21.13	19.86	21.94	16.65	19.13	19.13	19.32	18.74	20.21	15.74						
3670	24	18.44	14.86	19.56	10.92	20.85	4.96	16.43	13.38	17.62	9.66	18.98	3.92						
3670	27	19.25	17.82	20.18	14.75	21.28	9.67	17.30	16.39	18.30	13.55	19.46	8.68						
3670	30	20.18	20.14	20.92	17.96	21.82	13.75	18.30	18.30	19.10	16.80	20.07	12.81						
3670	33	21.23	21.23	21.77	20.53	22.49	17.20	19.41	19.41	20.02	19.42	20.80	16.31						
4080	24	19.00	15.39	20.02	11.34	21.21	5.27	17.04	13.94	18.12	10.10	19.38	4.25						
4080	27	19.84	18.41	20.67	15.23	21.66	10.04	17.94	17.00	18.83	14.04	19.90	9.07						
4080	30	20.80	20.79	21.43	18.48	22.24	14.17	18.97	18.97	19.67	17.35	20.54	13.25						
4080	33	21.88	21.88	22.32	21.11	22.94	17.67	20.41	20.41	20.62	20.03	21.29	16.80						
4490	24	19.46	15.84	20.38	11.68	21.46	5.50	17.55	14.41	18.53	10.46	19.68	4.50						
4490	27	20.33	18.91	21.06	15.62	21.95	10.32	18.49	17.53	19.27	14.46	20.23	9.37						
4490	30	21.33	21.33	21.85	18.93	22.56	14.50	19.54	19.54	20.13	17.82	20.90	13.61						
4490	33	22.44	22.44	22.77	21.61	23.28	18.05	20.90	20.90	21.11	20.55	21.69	17.21						
4900	24	19.83	16.22	20.64	11.94	21.62	5.65	17.96	14.81	18.84	10.75	19.89	4.67						
4900	27	20.73	19.34	21.35	15.93	22.14	10.52	18.93	17.98	19.61	14.79	20.46	9.59						
4900	30	21.75	21.75	22.17	19.30	22.77	14.76	20.01	20.01	20.50	18.21	21.16	13.88						
4900	33	22.89	22.89	23.12	22.02	23.53	18.36	21.30	21.30	21.51	20.99	21.98	17.54						

**Notes:**

1. All capacities shown are gross and have not considered indoor fan heat. To obtain **NET** cooling capacity subtract indoor fan heat. For indoor fan heat formula, refer to appropriate airflow table notes.
2. TGC = Total Gross Capacity
3. SHC = Sensible Heat Capacity



## Performance Data

**Table 14. Gross cooling capacities MBh 6 tons standard efficiency—WSC072ED (IP)**

CFM Airflow		Ent DB (F)		Ambient Temperature															
				85				95				105							
				Entering Wet Bulb				Entering Wet Bulb				Entering Wet Bulb							
				61		67		73		61		67		73		61		67	
TGC		SHC		TGC		SHC		TGC		SHC		TGC		SHC		TGC		SHC	
1920	75	75.65	59.45	79.16	44.16	83.25	22.00	71.65	56.57	75.38	42.03	79.71	20.61	66.65	52.95	70.61	39.15	75.15	18.47
1920	80	77.68	68.84	80.53	56.54	83.97	37.37	73.90	66.14	76.97	54.59	80.63	36.16	69.11	62.70	72.40	51.88	76.29	34.20
1920	85	80.12	76.07	82.31	66.76	85.09	50.58	76.55	73.55	78.96	64.98	81.97	49.54	71.97	70.28	74.61	62.46	77.84	47.76
1920	90	82.97	81.14	84.50	74.82	86.63	61.63	79.61	78.80	81.37	73.22	83.71	60.76	75.25	75.25	77.23	70.87	79.80	59.15
2160	75	77.42	61.33	80.58	45.66	84.32	23.12	73.59	58.53	76.97	43.60	80.93	21.80	68.75	54.98	72.35	40.80	76.54	19.74
2160	80	79.56	70.90	82.05	58.22	85.14	38.67	75.93	68.28	78.65	56.34	81.96	37.52	71.31	64.91	74.25	53.71	77.78	35.64
2160	85	82.10	78.31	83.94	68.62	86.37	52.05	78.69	75.86	80.75	66.91	83.40	51.09	74.27	72.67	76.56	64.46	79.44	49.38
2160	90	85.05	83.56	86.23	76.86	88.00	63.28	81.85	81.29	83.26	75.33	85.25	62.49	77.65	77.65	79.28	73.05	81.50	60.96
2400	75	78.86	62.92	81.66	46.87	85.05	23.95	75.19	60.20	78.21	44.89	81.82	22.71	70.51	56.73	73.76	42.16	77.59	20.72
2400	80	81.09	72.68	83.24	59.61	85.97	39.68	77.63	70.13	80.00	57.81	82.96	38.61	73.17	66.84	75.76	55.26	78.94	36.80
2400	85	83.74	80.27	85.22	70.19	87.30	53.25	80.49	77.90	82.20	68.57	84.50	52.36	76.24	74.78	78.17	66.19	80.69	50.72
2400	90	86.79	85.70	87.62	78.61	89.04	64.65	83.76	83.51	84.81	77.16	86.45	63.94	79.72	79.72	80.99	74.96	82.86	62.48
2640	75	79.95	64.24	82.40	47.81	85.44	24.50	76.44	61.59	79.11	45.90	82.37	23.33	71.93	58.20	74.82	43.25	78.31	21.42
2640	80	82.29	74.18	84.08	60.73	86.46	40.41	78.99	71.71	81.01	59.00	83.61	39.42	74.69	68.49	76.93	56.52	79.75	37.69
2640	85	85.04	81.95	86.17	71.49	87.89	54.16	81.95	79.65	83.31	69.94	85.25	53.35	77.86	76.61	79.44	67.64	81.61	51.79
2640	90	88.20	87.56	88.67	80.09	89.73	65.75	85.32	85.32	86.02	78.71	87.31	65.11	81.44	81.44	82.36	76.59	83.87	63.73
2880	75	80.71	65.28	82.80	48.46	85.49	24.77	77.36	62.71	79.68	46.63	82.58	23.68	73.01	59.39	75.55	44.06	78.68	21.85
2880	80	83.15	75.40	84.59	61.57	86.61	40.87	80.01	73.00	81.67	59.91	83.92	39.95	75.87	69.86	77.76	57.51	80.23	38.29
2880	85	86.00	83.35	86.78	72.51	88.15	54.80	83.08	81.13	84.08	71.03	85.67	54.06	79.15	78.17	80.37	68.81	82.19	52.58
2880	90	89.26	89.14	89.38	81.29	90.09	66.57	86.55	86.55	86.89	79.99	87.83	66.00	82.83	82.83	83.40	77.94	84.55	64.70
CFM Airflow		Ent DB (F)		Ambient Temperature															
				115				125											
				Entering Wet Bulb				Entering Wet Bulb											
				61		67		73		61		67		73					
TGC		SHC		TGC		SHC		TGC		SHC		TGC		SHC					
1920	75	60.65	48.59	64.83	35.53	69.59	15.59	53.64	43.48	58.04	31.16	63.03	11.96						
1920	80	63.32	58.51	66.84	48.44	70.95	31.49	56.52	53.58	60.26	44.24	64.60	28.04						
1920	85	66.39	66.27	69.25	59.19	72.71	45.23	59.81	59.81	62.89	55.17	66.57	41.95						
1920	90	69.88	69.88	72.08	67.77	74.88	56.80	65.27	65.27	65.93	63.93	68.95	53.70						
2160	75	62.91	50.69	66.73	37.25	71.15	16.93	56.06	45.66	60.11	32.95	64.75	13.37						
2160	80	65.68	60.80	68.84	50.34	72.60	33.01	59.04	55.94	62.43	46.22	66.41	29.63						
2160	85	68.86	68.74	71.37	61.27	74.46	46.92	62.43	62.43	65.17	57.33	68.49	43.72						
2160	90	72.44	72.44	74.30	70.03	76.74	58.68	66.23	66.23	68.31	66.27	70.97	55.66						
2400	75	64.83	52.52	68.30	38.69	72.36	17.99	58.14	47.56	61.84	34.47	66.12	14.51						
2400	80	67.70	62.80	70.51	51.96	73.92	34.25	61.23	58.02	64.26	47.92	67.89	30.94						
2400	85	70.98	70.92	73.14	63.07	75.88	48.34	64.72	64.72	67.10	59.20	70.07	45.22						
2400	90	74.67	74.67	76.17	72.02	78.26	60.28	69.64	69.64	70.34	68.33	72.65	57.33						
2640	75	66.41	54.06	69.53	39.85	73.23	18.77	59.89	49.18	63.23	35.71	67.16	15.36						
2640	80	69.38	64.53	71.84	53.30	74.89	35.21	63.07	59.82	65.76	49.34	69.03	31.98						
2640	85	72.77	72.77	74.57	64.59	76.96	49.49	66.67	66.67	68.69	60.80	71.31	46.44						
2640	90	76.56	76.56	77.70	73.72	79.44	61.60	71.32	71.32	72.04	70.11	74.00	58.73						
2880	75	67.65	55.33	70.41	40.73	73.77	19.27	61.29	50.52	64.28	36.67	67.85	15.94						
2880	80	70.73	65.97	72.83	54.37	75.53	35.89	64.58	61.34	66.91	50.48	69.83	32.74						
2880	85	74.21	74.21	75.66	65.84	77.70	50.35	68.28	68.28	69.95	62.12	72.21	47.37						
2880	90	78.11	78.11	78.90	75.15	80.28	62.65	72.66	72.66	73.40	71.61	75.00	59.85						

**Notes:**

1. All capacities shown are gross and have not considered indoor fan heat. To obtain **NET** cooling capacity subtract indoor fan heat. For indoor fan heat formula, refer to appropriate airflow table notes.
2. TGC = Total Gross Capacity
3. SHC = Sensible Heat Capacity

**Table 15. Gross cooling capacities kw 7½ tons standard efficiency – WSC090ED (SI)**

m <sup>3</sup> /h Airflow		Ambient Temperature																		
		30						35						40						
		Entering Wet Bulb						Entering Wet Bulb						Entering Wet Bulb						
		Ent DB (C)	16	19	22	TGC	SHC	16	19	22	TGC	SHC	16	19	22	TGC	SHC	16	19	22
4080	24	26.27	20.95	27.84	15.80	29.72	8.16	24.76	19.87	26.36	15.00	28.26	7.64	23.09	18.67	24.72	14.08	26.64	7.00	
4080	27	27.09	24.42	28.35	20.31	29.92	13.72	25.63	23.35	26.92	19.52	28.51	13.21	24.00	22.15	25.32	18.61	26.93	12.58	
4080	30	28.11	27.14	29.07	24.08	30.32	18.53	26.69	26.07	27.68	23.29	28.96	18.03	25.11	24.89	26.12	22.39	27.42	17.41	
4080	33	29.32	29.11	29.98	27.10	30.93	22.60	27.95	27.95	28.63	26.32	29.60	22.11	26.41	26.41	27.11	25.43	28.11	21.49	
4590	24	27.02	21.81	28.45	16.51	30.18	8.74	25.54	20.74	27.00	15.73	28.75	8.23	23.90	19.55	25.38	14.82	27.15	7.60	
4590	27	27.89	25.33	29.01	21.08	30.43	14.35	26.46	24.27	27.60	20.30	29.05	13.85	24.85	23.09	26.02	19.40	27.49	13.23	
4590	30	28.96	28.11	29.77	24.90	30.89	19.22	27.57	27.05	28.41	24.13	29.54	18.73	26.01	25.88	26.87	23.24	28.03	18.12	
4590	33	30.23	30.13	30.73	27.98	31.54	23.34	28.88	28.88	29.41	27.22	30.24	22.86	27.36	27.36	27.92	26.33	28.77	22.26	
5100	24	27.63	22.54	28.91	17.10	30.49	9.19	26.17	21.48	27.48	16.33	29.08	8.69	24.55	20.30	25.88	15.43	27.51	8.07	
5100	27	28.55	26.11	29.52	21.73	30.79	14.86	27.14	25.07	28.14	20.96	29.43	14.37	25.56	23.90	26.58	20.07	27.90	13.76	
5100	30	29.67	28.94	30.33	25.60	31.30	19.78	28.30	27.91	28.99	24.85	29.98	19.30	26.76	26.75	27.48	23.96	28.49	18.70	
5100	33	30.98	30.98	31.34	28.73	32.00	23.96	29.66	29.66	30.04	27.98	30.72	23.49	28.16	28.16	28.57	27.11	29.28	22.90	
5610	24	28.08	23.13	29.22	17.56	30.65	9.50	26.65	22.09	27.81	16.80	29.27	9.02	25.05	20.92	26.23	15.91	27.71	8.41	
5610	27	29.05	26.77	29.88	22.24	31.00	15.23	27.66	25.73	28.51	21.48	29.66	14.75	26.11	24.58	26.98	20.61	28.15	14.16	
5610	30	30.22	29.65	30.74	26.17	31.55	20.21	28.88	28.63	29.42	25.43	30.26	19.74	27.36	27.36	27.93	24.56	28.79	19.15	
5610	33	31.59	31.59	31.80	29.36	32.30	24.44	30.28	30.28	30.52	28.62	31.05	23.98	28.81	28.81	29.07	27.76	29.63	23.40	
6120	24	28.39	23.60	29.37	17.89	30.66	9.69	26.98	22.57	27.99	17.14	29.30	9.22	25.40	21.42	26.44	16.26	27.77	8.63	
6120	27	29.41	27.29	30.08	22.62	31.06	15.47	28.04	26.27	28.74	21.88	29.74	15.01	26.51	25.13	27.23	21.02	28.26	14.43	
6120	30	30.62	30.24	30.99	26.61	31.66	20.51	29.30	29.22	29.69	25.88	30.39	20.05	27.81	27.81	28.23	25.02	28.95	19.48	
6120	33	32.04	32.04	32.10	29.86	32.46	24.80	30.76	30.76	30.84	29.13	31.23	24.35	29.31	29.31	29.42	28.28	29.83	23.79	
m <sup>3</sup> /h Airflow		Ambient Temperature																		
		45									52									
		Entering Wet Bulb									Entering Wet Bulb									
		Ent DB (C)	16	19	22	TGC	SHC	16	19	22	TGC	SHC	16	19	22	TGC	SHC			
4080	24	21.25	17.34	22.90	13.03	24.85	6.24	19.24	15.90	20.92	11.86	22.89	5.35							
4080	27	22.20	20.84	23.55	17.57	25.19	11.82	20.24	19.40	21.61	16.41	23.27	10.94							
4080	30	23.35	23.35	24.39	21.36	25.72	16.66	21.43	21.43	22.49	20.21	23.85	15.79							
4080	33	24.70	24.70	25.43	24.41	26.45	20.75	23.34	23.34	23.58	23.27	24.62	19.89							
4590	24	22.08	18.24	23.58	13.78	25.38	6.85	20.09	16.80	21.62	12.63	23.45	5.97							
4590	27	23.08	21.79	24.28	18.38	25.77	12.49	21.14	20.36	22.36	17.23	23.88	11.62							
4590	30	24.28	24.28	25.17	22.23	26.35	17.38	22.38	22.38	23.29	21.09	24.50	16.53							
4590	33	25.68	25.68	26.26	25.33	27.13	21.53	24.18	24.18	24.43	24.20	25.33	20.68							
5100	24	22.76	19.00	24.11	14.41	25.76	7.33	20.79	17.58	22.17	13.27	23.85	6.47							
5100	27	23.81	22.61	24.85	19.06	26.20	13.03	21.89	21.19	22.96	17.92	24.33	12.18							
5100	30	25.06	25.06	25.79	22.96	26.83	17.98	23.18	23.18	23.94	21.84	25.00	17.13							
5100	33	26.50	26.50	26.93	26.12	27.66	22.18	24.87	24.87	25.13	25.00	25.88	21.35							
5610	24	23.28	19.64	24.49	14.90	25.99	7.69	21.34	18.23	22.57	13.77	24.10	6.84							
5610	27	24.38	23.30	25.28	19.61	26.48	13.44	22.48	21.89	23.41	18.49	24.63	12.60							
5610	30	25.68	25.68	26.27	23.57	27.16	18.44	23.83	23.83	24.44	22.46	25.36	17.61							
5610	33	27.17	27.17	27.46	26.78	28.04	22.70	25.67	25.67	25.67	25.67	26.28	21.88							
6120	24	23.65	20.14	24.71	15.27	26.07	7.91	21.74	18.74	22.82	14.15	24.20	7.07							
6120	27	24.80	23.86	25.55	20.03	26.60	13.72	22.93	22.47	23.71	18.92	24.78	12.89							
6120	30	26.15	26.15	26.59	24.05	27.34	18.78	24.32	24.32	24.79	22.95	25.56	17.96							
6120	33	27.55	27.55	27.83	27.32	28.26	23.10	26.07	26.07	26.07	26.07	26.53	22.29							

**Notes:**

1. All capacities shown are gross and have not considered indoor fan heat. To obtain **NET** cooling capacity subtract indoor fan heat. For indoor fan heat formula, refer to appropriate airflow table notes.
2. TGC = Total Gross Capacity
3. SHC = Sensible Heat Capacity



## Performance Data

**Table 16. Gross cooling capacities MBh 7½ tons standard efficiency—WSC090ED (IP)**

CFM Airflow		Ent DB (F)		Ambient Temperature															
				85				95				105							
				Entering Wet Bulb				Entering Wet Bulb				Entering Wet Bulb							
				61		67		73		61		67		73		61		67	
		TGC	SHC	TGC	SHC	TGC	SHC	TGC	SHC	TGC	SHC	TGC	SHC	TGC	SHC	TGC	SHC	TGC	SHC
2400	75	89.62	71.49	95.00	53.91	101.39	27.85	84.50	67.80	89.96	51.18	96.44	26.08	78.80	63.70	84.34	48.03	90.90	23.89
2400	80	92.42	83.31	96.75	69.30	102.09	46.82	87.45	79.66	91.86	66.60	97.28	45.08	81.89	75.59	86.39	63.49	91.90	42.92
2400	85	95.90	92.60	99.18	82.15	103.47	63.24	91.07	88.97	94.43	79.48	98.81	61.53	85.67	84.93	89.11	76.40	93.57	59.40
2400	90	100.05	99.33	102.28	92.46	105.52	77.11	95.38	95.38	97.69	89.82	101.01	75.43	90.12	90.12	92.51	86.76	95.93	73.33
2700	75	92.21	74.41	97.08	56.35	102.97	29.82	87.16	70.76	92.12	53.66	98.09	28.09	81.54	66.70	86.58	50.56	92.64	25.94
2700	80	95.18	86.43	99.00	71.94	103.84	48.97	90.28	82.81	94.19	69.28	99.11	47.27	84.81	78.78	88.80	66.20	93.81	45.15
2700	85	98.82	95.90	101.59	84.98	105.38	65.58	94.07	92.31	96.93	82.35	100.80	63.91	88.75	88.31	91.69	79.30	95.65	61.82
2700	90	103.14	102.82	104.87	95.47	107.61	79.64	98.55	98.55	100.35	92.87	103.17	78.00	93.37	93.37	95.26	89.86	98.17	75.95
3000	75	94.28	76.89	98.65	58.35	104.03	31.34	89.31	73.29	93.76	55.71	99.24	29.65	83.77	69.27	88.31	52.64	93.86	27.54
3000	80	97.41	89.10	100.73	74.13	105.07	50.69	92.60	85.53	96.00	71.51	100.42	49.03	87.20	81.54	90.69	68.48	95.20	46.95
3000	85	101.23	98.76	103.50	87.36	106.78	67.49	96.56	95.22	98.91	84.77	102.28	65.86	91.31	91.26	93.75	81.77	97.20	63.81
3000	90	105.72	105.72	106.94	98.04	109.17	81.74	101.20	101.20	102.50	95.49	104.82	80.14	96.10	96.10	97.49	92.51	99.89	78.12
3300	75	95.83	78.94	99.70	59.92	104.58	32.42	90.94	75.37	94.89	57.31	99.86	30.78	85.48	71.40	89.51	54.29	94.57	28.71
3300	80	99.13	91.33	101.95	75.88	105.78	51.96	94.40	87.80	97.30	73.31	101.21	50.34	89.08	83.85	92.07	70.32	96.07	48.31
3300	85	103.11	101.18	104.88	89.30	107.66	68.95	98.53	97.68	100.38	86.76	103.24	67.36	93.36	93.36	95.29	83.80	98.24	65.36
3300	90	107.77	107.77	108.49	100.18	110.22	83.39	103.33	103.33	104.13	97.66	105.95	81.83	98.31	98.31	99.20	94.73	101.10	79.86
3600	75	96.86	80.54	100.23	61.04	104.61	33.07	92.06	77.02	95.50	58.48	99.97	31.46	86.67	73.08	90.20	55.50	94.75	29.44
3600	80	100.34	93.13	102.65	77.20	105.98	52.80	95.68	89.64	98.07	74.66	101.49	51.22	90.44	85.73	92.92	71.71	96.42	49.22
3600	85	104.49	103.17	105.75	90.81	108.03	69.97	99.98	99.71	101.32	88.30	103.69	68.43	94.89	94.89	96.32	85.38	98.77	66.46
3600	90	109.31	109.31	109.52	101.87	110.75	84.61	104.95	104.95	105.25	99.40	106.56	83.09	100.01	100.01	100.39	96.51	101.79	81.16
CFM Airflow		Ent DB (F)		Ambient Temperature															
				115				125											
				Entering Wet Bulb				Entering Wet Bulb											
				61		67		73		61		67		73					
		TGC	SHC	TGC	SHC	TGC	SHC	TGC	SHC	TGC	SHC	TGC	SHC	TGC	SHC	TGC	SHC	TGC	SHC
2400	75	72.52	59.18	78.15	44.46	84.79	21.28	65.66	54.24	71.38	40.48	78.11	18.26						
2400	80	75.76	71.09	80.34	59.95	85.94	40.34	69.06	66.19	73.72	56.00	79.40	37.35						
2400	85	79.69	79.69	83.22	72.89	87.76	56.85	73.13	73.13	76.74	68.97	81.37	53.89						
2400	90	84.29	84.29	86.77	83.29	90.26	70.81	79.64	79.64	80.44	79.40	84.02	67.88						
2700	75	75.34	62.22	80.47	47.03	86.61	23.37	68.57	57.33	73.78	43.09	80.00	20.39						
2700	80	78.76	74.33	82.83	62.71	87.92	42.62	72.13	69.47	76.29	58.80	81.47	39.66						
2700	85	82.85	82.85	85.87	75.84	89.91	59.32	76.37	76.37	79.48	71.96	83.60	56.40						
2700	90	87.62	87.62	89.59	86.43	92.58	73.47	82.51	82.51	83.34	82.58	86.42	70.58						
3000	75	77.65	64.83	82.27	49.16	87.91	25.02	70.95	59.98	75.66	45.26	81.38	22.08						
3000	80	81.23	77.13	84.80	65.03	89.39	44.46	74.68	72.31	78.34	61.16	83.01	41.54						
3000	85	85.49	85.49	88.01	78.35	91.55	61.35	79.09	79.09	81.70	74.51	85.32	58.47						
3000	90	90.43	90.43	91.90	89.12	94.39	75.69	84.87	84.87	85.73	85.32	88.30	72.84						
3300	75	79.44	67.00	83.56	50.85	88.69	26.23	72.82	62.19	77.02	46.99	82.24	23.33						
3300	80	83.19	79.49	86.26	66.91	90.34	45.85	76.72	74.71	79.87	63.08	84.04	42.99						
3300	85	87.62	87.62	89.63	80.42	92.67	62.94	81.30	81.30	83.40	76.62	86.52	60.10						
3300	90	92.72	92.72	93.69	91.38	95.67	77.47	87.60	87.60	87.60	87.60	89.67	74.66						
3600	75	80.71	68.73	84.33	52.10	88.96	27.00	74.17	63.96	77.87	48.28	82.59	24.14						
3600	80	84.63	81.41	87.19	68.35	90.78	46.81	78.24	76.67	80.89	64.56	84.56	43.99						
3600	85	89.22	89.22	90.74	82.05	93.27	64.08	82.98	82.98	84.58	78.29	87.20	61.29						
3600	90	94.01	94.01	94.96	93.20	96.44	78.81	88.95	88.95	88.95	88.95	90.52	76.04						

**Notes:**

1. All capacities shown are gross and have not considered indoor fan heat. To obtain **NET** cooling capacity subtract indoor fan heat. For indoor fan heat formula, refer to appropriate airflow table notes.
2. TGC = Total Gross Capacity
3. SHC = Sensible Heat Capacity

Table 17. Gross cooling capacities kw 10 tons standard efficiency—WSC120ED (SI)

m <sup>3</sup> /h Airflow		Ent DB (C)		Ambient Temperature																	
				30						35						40					
				Entering Wet Bulb						Entering Wet Bulb						Entering Wet Bulb					
				16		19		22		16		19		22		16		19		22	
		TGC	SHC	TGC	SHC	TGC	SHC	TGC	SHC	TGC	SHC	TGC	SHC	TGC	SHC	TGC	SHC	TGC	SHC		
5440	24	34.15	27.23	35.94	20.46	38.09	10.37	31.90	25.64	33.71	19.27	35.90	9.59	29.32	23.83	31.15	17.86	33.37	8.57		
5440	27	35.18	31.76	36.60	26.42	38.39	17.77	32.99	30.15	34.43	25.21	36.25	16.96	30.46	28.32	31.94	23.78	33.78	15.92		
5440	30	36.45	35.28	37.50	31.38	38.93	24.16	34.31	33.65	35.39	30.15	36.84	23.32	31.84	31.80	32.95	28.69	34.43	22.27		
5440	33	37.95	37.81	38.63	35.33	39.69	29.54	35.87	35.87	36.58	34.08	37.67	28.69	33.46	33.46	34.20	32.60	35.32	27.61		
6120	24	34.95	28.28	36.59	21.35	38.59	11.10	32.71	26.71	34.37	20.17	36.41	10.32	30.14	24.90	31.83	18.77	33.89	9.32		
6120	27	36.06	32.87	37.33	27.36	38.97	18.55	33.88	31.27	35.17	26.16	36.84	17.74	31.36	29.44	32.69	24.74	34.39	16.72		
6120	30	37.40	36.44	38.30	32.37	39.58	24.99	35.28	34.82	36.21	31.15	37.51	24.16	32.82	32.82	33.78	29.70	35.11	23.11		
6120	33	38.98	38.98	39.52	36.38	40.43	30.43	36.91	36.91	37.48	35.14	38.42	29.58	34.52	34.52	35.11	33.66	36.08	28.51		
6800	24	35.59	29.19	37.08	22.09	38.94	11.68	33.36	27.63	34.88	20.93	36.76	10.91	30.80	25.83	32.34	19.53	34.26	9.91		
6800	27	36.78	33.83	37.90	28.16	39.39	19.18	34.61	32.24	35.76	26.97	37.28	18.39	32.11	30.42	33.28	25.55	34.83	17.37		
6800	30	38.20	37.46	38.95	33.22	40.08	25.67	36.09	35.85	36.87	32.01	38.02	24.86	33.64	33.64	34.45	30.57	35.64	23.82		
6800	33	39.85	39.85	40.24	37.28	41.01	31.16	37.80	37.80	38.22	36.05	39.01	30.33	35.42	35.42	35.86	34.58	36.68	29.26		
7480	24	36.08	29.96	37.41	22.69	39.12	12.11	33.86	28.40	35.22	21.53	36.96	11.35	31.31	26.61	32.70	20.14	34.47	10.36		
7480	27	37.34	34.64	38.31	28.81	39.66	19.67	35.18	33.06	36.18	27.63	37.55	18.88	32.69	31.25	33.72	26.22	35.12	17.87		
7480	30	38.84	38.33	39.45	33.93	40.42	26.21	36.74	36.73	37.37	32.72	38.38	25.41	34.31	34.31	34.97	31.29	36.00	24.37		
7480	33	40.57	40.57	40.81	38.04	41.43	31.76	38.53	38.53	38.80	36.81	39.44	30.93	36.16	36.16	36.45	35.36	37.12	29.87		
8160	24	36.40	30.58	37.59	23.15	39.15	12.40	34.20	29.03	35.41	21.99	37.00	11.65	31.67	27.25	32.91	20.61	34.52	10.67		
8160	27	37.75	35.32	38.57	29.32	39.76	20.01	35.60	33.74	36.45	28.14	37.67	19.23	33.13	31.94	34.00	26.74	35.25	18.23		
8160	30	39.32	39.05	39.78	34.49	40.61	26.61	37.24	37.24	37.72	33.29	38.58	25.81	34.82	34.82	35.33	31.87	36.22	24.78		
8160	33	41.14	41.14	41.23	38.65	41.69	32.20	39.11	39.11	39.22	37.43	39.72	31.38	36.75	36.75	36.89	35.99	37.41	30.34		
m <sup>3</sup> /h Airflow		Ent DB (C)		Ambient Temperature																	
				45						52											
				Entering Wet Bulb						Entering Wet Bulb											
				16		19		22		16		19		22							
		TGC	SHC	TGC	SHC	TGC	SHC	TGC	SHC	TGC	SHC	TGC	SHC	TGC	SHC	TGC	SHC	TGC	SHC		
5440	24	26.40	21.79	28.27	16.22	30.51	7.33	23.16	19.52	25.05	14.35	27.32	5.86								
5440	27	27.61	26.25	29.11	22.11	30.98	14.66	24.42	23.96	25.95	20.22	27.85	13.16								
5440	30	29.04	29.04	30.18	27.00	31.69	20.98	25.92	25.92	27.08	25.09	28.62	19.46								
5440	33	31.17	31.17	31.49	30.89	32.63	26.30	28.44	28.44	28.44	28.44	29.62	24.76								
6120	24	27.24	22.87	28.95	17.13	31.05	8.08	24.00	20.61	25.75	15.27	27.87	6.62								
6120	27	28.52	27.39	29.87	23.08	31.60	15.46	25.34	25.11	26.72	21.20	28.48	13.97								
6120	30	30.04	30.04	31.02	28.02	32.38	21.84	26.92	26.92	27.93	26.12	29.32	20.33								
6120	33	32.08	32.08	32.41	31.97	33.40	27.21	29.38	29.38	29.38	29.38	30.40	25.68								
6800	24	27.91	23.81	29.48	17.90	31.43	8.69	24.69	21.56	26.29	16.05	28.26	7.23								
6800	27	29.28	28.38	30.48	23.90	32.05	16.12	26.11	26.10	27.34	22.03	28.95	14.64								
6800	30	30.87	30.87	31.71	28.90	32.92	22.55	27.77	27.77	28.63	27.00	29.87	21.05								
6800	33	32.84	32.84	33.17	32.89	34.02	27.97	30.15	30.15	30.15	30.15	31.03	26.45								
7480	24	28.44	24.60	29.85	18.53	31.65	9.15	25.23	22.35	26.67	16.68	28.50	7.70								
7480	27	29.87	29.22	30.93	24.58	32.36	16.63	26.73	26.73	27.81	22.71	29.26	15.16								
7480	30	31.55	31.55	32.24	29.63	33.30	23.11	28.46	28.46	29.17	27.74	30.26	21.62								
7480	33	33.44	33.44	33.78	33.68	34.48	28.59	30.77	30.77	30.77	30.77	31.50	27.08								
8160	24	28.80	25.24	30.07	19.01	31.71	9.46	25.61	23.01	26.90	17.17	28.57	8.02								
8160	27	30.32	29.91	31.22	25.11	32.50	17.00	27.18	27.18	28.11	23.25	29.42	15.54								
8160	30	32.07	32.07	32.61	30.21	33.52	23.53	28.99	28.99	29.56	28.33	30.50	22.05								
8160	33	34.23	34.23	34.23	34.23	34.78	29.06	31.24	31.24	31.24	31.24	31.81	27.56								

Notes:

1. All capacities shown are gross and have not considered indoor fan heat. To obtain **NET** cooling capacity subtract indoor fan heat. For indoor fan heat formula, refer to appropriate airflow table notes.
2. TGC = Total Gross Capacity
3. SHC = Sensible Heat Capacity



## Performance Data

**Table 18. Gross cooling capacities MBh 10 tons standard efficiency—WSC120ED (SI)**

CFM Airflow		Ent DB (F)		Ambient Temperature																	
				85						95						105					
				Entering Wet Bulb						Entering Wet Bulb						Entering Wet Bulb					
				61		67		73		61		67		73		61		67		73	
		TGC	SHC	TGC	SHC	TGC	SHC	TGC	SHC	TGC	SHC	TGC	SHC	TGC	SHC	TGC	SHC	TGC	SHC		
3200	75	116.54	92.90	122.62	69.80	129.98	35.40	108.85	87.50	115.03	65.76	122.48	32.71	100.03	81.32	106.30	60.94	113.85	29.25		
3200	80	120.05	108.36	124.89	90.14	131.00	60.62	112.56	102.88	117.49	86.02	123.70	57.86	103.94	96.62	108.97	81.12	115.27	54.32		
3200	85	124.36	120.39	127.95	107.06	132.82	82.42	117.07	114.83	120.76	102.86	125.72	79.59	108.65	108.50	112.43	97.89	117.49	75.97		
3200	90	129.48	129.00	131.82	120.55	135.44	100.80	122.38	122.38	124.82	116.28	128.54	97.89	114.16	114.16	116.69	111.23	120.50	94.20		
3600	75	119.26	96.51	124.83	72.84	131.69	37.87	111.61	91.13	117.28	68.83	124.23	35.22	102.84	84.98	108.60	64.03	115.64	31.78		
3600	80	123.04	112.14	127.37	93.36	132.97	63.28	115.59	106.69	120.01	89.27	125.71	60.55	107.01	100.46	111.53	84.40	117.33	57.04		
3600	85	127.62	124.35	130.70	110.46	135.06	85.26	120.37	118.82	123.54	106.29	128.00	82.45	111.99	111.99	115.26	101.35	119.81	78.87		
3600	90	133.00	133.00	134.83	124.13	137.95	103.82	125.95	125.95	127.88	119.89	131.08	100.93	117.77	117.77	119.79	114.87	123.09	97.27		
4000	75	121.45	99.61	126.51	75.39	132.86	39.85	113.84	94.26	119.00	71.40	125.44	37.23	105.11	88.14	110.36	66.63	116.90	33.82		
4000	80	125.49	115.42	129.31	96.08	134.41	65.44	118.09	110.00	122.00	92.02	127.19	62.73	109.55	103.80	113.56	87.18	118.85	59.25		
4000	85	130.34	127.81	132.91	113.36	136.76	87.60	123.13	122.32	125.80	109.22	129.74	84.82	114.80	114.80	117.56	104.30	121.60	81.26		
4000	90	135.99	135.99	137.31	127.21	139.92	106.34	128.98	128.98	130.40	123.00	133.10	103.48	120.84	120.84	122.36	118.01	125.15	99.85		
4400	75	123.10	102.22	127.66	77.43	133.49	41.34	115.53	96.90	120.19	73.47	126.12	38.74	106.84	90.80	111.59	68.74	117.62	35.36		
4400	80	127.41	118.21	130.72	98.31	135.31	67.10	120.05	112.82	123.45	94.27	128.14	64.42	111.56	106.64	115.06	89.46	119.83	60.97		
4400	85	132.53	130.78	134.59	115.76	137.93	89.44	125.36	125.31	127.52	111.65	130.96	86.69	117.07	117.07	119.32	106.77	122.85	83.16		
4400	90	138.44	138.44	139.26	129.80	141.35	108.36	131.48	131.48	132.39	125.61	134.57	105.53	123.38	123.38	124.39	120.65	126.67	101.93		
4800	75	124.22	104.33	128.27	78.98	133.59	42.32	116.70	99.04	120.84	75.05	126.26	39.75	108.05	92.97	112.28	70.34	117.80	36.40		
4800	80	128.80	120.50	131.60	100.04	135.68	68.26	121.48	115.14	124.37	96.03	128.55	65.62	113.03	108.99	116.02	91.25	120.29	62.19		
4800	85	134.18	133.25	135.73	117.67	138.57	90.78	127.06	127.06	128.71	113.59	131.63	88.06	118.81	118.81	120.55	108.73	123.57	84.56		
4800	90	140.36	140.36	140.67	131.88	142.26	109.88	133.44	133.44	133.84	127.73	135.52	107.08	125.38	125.38	125.88	122.79	127.65	103.51		
CFM Airflow		Ent DB (F)		Ambient Temperature																	
				115						125											
				Entering Wet Bulb						Entering Wet Bulb											
				61		67		73		61		67		73							
		TGC	SHC	TGC	SHC	TGC	SHC	TGC	SHC	TGC	SHC	TGC	SHC	TGC	SHC	TGC	SHC	TGC	SHC		
3200	75	90.08	74.36	96.45	55.34	104.10	25.01	79.01	66.62	85.47	48.96	93.22	19.99								
3200	80	94.19	89.58	99.31	75.45	105.71	50.01	83.32	81.77	88.54	69.00	95.03	44.91								
3200	85	99.10	99.10	102.98	92.14	108.13	71.58	88.43	88.43	92.40	85.61	97.64	66.41								
3200	90	106.36	106.36	107.44	105.40	111.34	89.73	97.06	97.06	97.06	97.06	101.06	84.49								
3600	75	92.93	78.04	98.79	58.46	105.93	27.57	81.90	70.34	87.86	52.11	95.09	22.58								
3600	80	97.31	93.45	101.92	78.75	107.81	52.75	86.48	85.67	91.18	72.33	97.17	47.68								
3600	85	102.49	102.49	105.85	95.62	110.49	74.50	91.85	91.85	95.31	89.12	100.05	69.36								
3600	90	109.47	109.47	110.58	109.07	113.98	92.83	100.24	100.24	100.24	100.24	103.73	87.62								
4000	75	95.25	81.24	100.60	61.09	107.23	29.64	84.26	73.55	89.70	54.77	96.43	24.68								
4000	80	99.89	96.82	103.99	81.56	109.37	54.99	89.10	89.07	93.30	75.17	98.77	49.96								
4000	85	105.33	105.33	108.19	98.61	112.32	76.93	94.74	94.74	97.69	92.14	101.92	71.82								
4000	90	112.05	112.05	113.19	112.24	116.07	95.44	102.89	102.89	102.89	102.89	105.87	90.25								
4400	75	97.03	83.93	101.87	63.22	107.99	31.21	86.08	76.28	91.02	56.93	97.23	26.27								
4400	80	101.94	99.70	105.53	83.87	110.40	56.74	91.19	91.19	94.88	77.50	99.84	51.73								
4400	85	107.65	107.65	109.99	101.10	113.62	78.86	97.10	97.10	99.54	94.66	103.26	73.77								
4400	90	114.10	114.10	115.26	114.91	117.64	97.55	105.00	105.00	105.00	105.00	107.47	92.39								
4800	75	98.27	86.13	102.60	64.85	108.21	32.28	87.37	78.50	91.79	58.59	97.50	27.37								
4800	80	103.45	102.07	106.53	85.69	110.90	57.99	92.74	92.74	95.92	79.35	100.38	53.01								
4800	85	109.43	109.43	111.26	103.09	114.38	80.29	98.92	98.92	100.85	96.68	104.06	75.23								
4800	90	116.79	116.79	116.79	116.79	118.66	99.16	106.58	106.58	106.58	106.58	108.54	94.02								

**Notes:**

1. All capacities shown are gross and have not considered indoor fan heat. To obtain **NET** cooling capacity subtract indoor fan heat. For indoor fan heat formula, refer to appropriate airflow table notes.
2. TGC = Total Gross Capacity
3. SHC = Sensible Heat Capacity





# Evaporator Fan Performance

**Table 1. Belt drive evaporator fan performance—5 tons—TSC060ED downflow airflow (SI)**

		External Static Pressure (Pascals)																			
		25		50		75		100		125		150		175		200		225		250	
m <sup>3</sup> /h	rpm	kW	rpm	kW	rpm	kW	rpm	kW	rpm	kW	rpm	kW	rpm	kW	rpm	kW	rpm	kW	rpm	kW	
<b>1.12 Nom kW Std Motor &amp; Field Supplied Low Static Drive<sup>(a)</sup></b>																					
2720	—	—	—	—	—	—	773	0.26	823	0.30	872	0.34	924	0.38	977	0.43	1021	0.48	1061	0.52	
3060	—	—	—	—	765	0.29	818	0.33	867	0.37	912	0.41	955	0.45	999	0.50	1045	0.55	1092	0.61	
3400	—	—	755	0.31	812	0.36	864	0.41	912	0.46	956	0.50	997	0.55	1037	0.59	1075	0.64	1116	0.70	
3740	743	0.33	806	0.39	861	0.45	911	0.50	958	0.56	1001	0.61	1042	0.66	1080	0.71	1116	0.76	1151	0.81	
4080	798	0.42	858	0.49	912	0.55	960	0.61	1005	0.67	1047	0.73	1087	0.78	1125	0.84	1160	0.89	1194	0.94	
<b>1.12 Nom kW Standard Motor &amp; Drive</b>																					

Continued

		External Static Pressure (Pascals)									
		275		300		325		350		375	
m <sup>3</sup> /h	rpm	kW	rpm	kW	rpm	kW	rpm	kW	rpm	kW	
<b>1.12 Nom kW Standard Motor &amp; Drive</b>											
2720	1097	0.56	1134	0.60	1167	0.64	1201	0.69	1232	0.73	
3060	1134	0.66	1171	0.71	1205	0.76	1237	0.80	1270	0.85	
3400	1157	0.75	1200	0.81	1240	0.87	1275	0.93	1307	0.98	
3740	1187	0.86	1223	0.92	1261	0.98	1300	1.04	1338	1.11	
4080	1226	1.00	1260	1.05	1292	1.11	1325	1.18	1358	1.24	

**Notes:**

1. For Standard Evaporator Fan Speed (RPM), reference [Table 97, p. 117](#).
2. Data includes pressure drop due to standard filters and wet coils.
3. Refer to [Table 107, p. 119](#) to determine additional static pressure drop due to other options/accessories.
4. 1.12 kW Fan Motor Heat (MBh) = 1.070 x Fan kW + 0.250
5. Factory supplied motors, in commercial equipment, are definite purpose motors, specifically designed and tested to operate reliably and continuously at all cataloged conditions. Using the full horsepower range of our fan motors as shown in our tabular data will not result in nuisance tripping or premature motor failure. Our product's warranty will not be affected.

(a) BAYLSDR005A



## Evaporator Fan Performance

**Table 2. Belt drive evaporator fan performance—5 tons—TSC060ED downflow airflow (IP)**

cfm	External Static Pressure (Inches of Water)																			
	.10		.20		.30		.40		.50		.60		.70		.80		.90		1.00	
	rpm	bhp	rpm	bhp	rpm	bhp	rpm	bhp	rpm	bhp	rpm	bhp	rpm	bhp	rpm	bhp	rpm	bhp	rpm	bhp
<b>1.5-hp Std Motor &amp; Field Supplied Low Static Drive<sup>(a)</sup></b>																				
1600	—	—	—	—	—	773	0.35	823	0.40	872	0.45	924	0.51	977	0.58	1021	0.64	1061	0.70	
1800	—	—	—	—	765	0.39	818	0.45	867	0.50	912	0.55	955	0.61	999	0.67	1045	0.74	1092	0.81
2000	—	—	755	0.42	812	0.49	864	0.55	912	0.61	956	0.68	997	0.74	1037	0.80	1075	0.86	1116	0.93
2200	743	0.45	806	0.53	861	0.60	911	0.67	958	0.75	1001	0.81	1042	0.88	1080	0.95	1116	1.01	1151	1.08
2400	798	0.56	858	0.65	912	0.74	960	0.82	1005	0.89	1047	0.97	1087	1.05	1125	1.12	1160	1.19	1194	1.27
<b>1.5-hp Std Motor &amp; Drive</b>																				

Continued

cfm	External Static Pressure (Inches of Water)									
	1.10		1.20		1.30		1.40		1.50	
	rpm	bhp	rpm	bhp	rpm	bhp	rpm	bhp	rpm	bhp
<b>1.5-hp Std Motor &amp; Drive</b>										
1600	1097	0.75	1134	0.81	1167	0.86	1201	0.92	1232	0.98
1800	1134	0.88	1171	0.95	1205	1.02	1237	1.08	1270	1.14
2000	1157	1.01	1200	1.09	1240	1.17	1275	1.25	1307	1.32
2200	1187	1.15	1223	1.23	1261	1.32	1300	1.40	1338	1.49
2400	1226	1.34	1260	1.41	1292	1.49	1325	1.58	1358	1.66

**Notes:**

1. For Standard Evaporator Fan Speed (RPM), reference [Table 97, p. 117](#).
2. Data includes pressure drop due to standard filters and wet coils.
3. Refer to [Table 108, p. 119](#) to determine additional static pressure drop due to other options/accessories.
4. 1.5-hp Fan Motor Heat (MBh) = 2.720 x Fan bhp + 0.850
5. Factory supplied motors, in commercial equipment, are definite purpose motors, specifically designed and tested to operate reliably and continuously at all cataloged conditions. Using the full horsepower range of our fan motors as shown in our tabular data will not result in nuisance tripping or premature motor failure. Our product's warranty will not be affected.

(a) BAYLSDR005A

## Evaporator Fan Performance

**Table 3. Belt drive evaporator fan performance—5 tons—TSC060ED horizontal airflow (SI)**

																						External Static Pressure (Pascals)									
		25		50		75		100		125		150		175		200		225		250											
m <sup>3</sup> /h	rpm	kW	rpm	kW	rpm	kW	rpm	kW	rpm	kW	rpm	kW	rpm	kW	rpm	kW	rpm	kW	rpm	kW											
<b>1.12 Nom kW Std Motor &amp; Field Supplied Low Static Drive<sup>(a)</sup></b>																															
2720	—	—	—	—	731	0.24	786	0.28	837	0.32	890	0.36	939	0.40	982	0.45	1021	0.49	1057	0.53											
3060	—	—	720	0.26	780	0.31	833	0.36	881	0.40	926	0.44	974	0.48	1020	0.53	1062	0.58	1100	0.63											
3400	—	—	773	0.33	830	0.39	881	0.44	928	0.49	972	0.54	1013	0.59	1055	0.63	1098	0.68	1138	0.73											
3740	765	0.35	827	0.42	881	0.48	931	0.54	976	0.59	1019	0.65	1059	0.71	1097	0.76	1134	0.81	1172	0.85											
4080	823	0.44	881	0.51	934	0.58	981	0.65	1025	0.71	1067	0.77	1106	0.84	1144	0.90	1179	0.96	1213	1.02											
<b>1.12 Nom kW Standard Motor &amp; Drive</b>																															

Continued

												External Static Pressure (Pascals)				
		275		300		325		350		375						
m <sup>3</sup> /h	rpm	kW	rpm	kW	rpm	kW	rpm	kW	rpm	kW						
<b>1.12 Nom kW Motor &amp; Drive</b>																
2720	1093	0.58	1128	0.62	1161	0.67	1193	0.72	1226	0.77						
3060	1135	0.68	1168	0.73	1201	0.78	1231	0.83	1263	0.88						
3400	1176	0.79	1211	0.84	1243	0.90	1273	0.95	1303	1.01						
3740	1212	0.91	1249	0.97	1284	1.03	1315	1.09	1346	1.15						
4080	1247	1.07	1282	1.11	1318	1.18	1353	1.24	—	—						

**Notes:**

1. For Standard Evaporator Fan Speed (RPM), reference [Table 97, p. 117](#).
2. Data includes pressure drop due to standard filters and wet coils.
3. Refer to [Table 107, p. 119](#) to determine additional static pressure drop due to other options/accessories.
4. 1.12 kW Fan Motor Heat (MBh) = 1.070 x Fan kW + 0.250
5. Factory supplied motors, in commercial equipment, are definite purpose motors, specifically designed and tested to operate reliably and continuously at all cataloged conditions. Using the full horsepower range of our fan motors as shown in our tabular data will not result in nuisance tripping or premature motor failure. Our product's warranty will not be affected.

(a) BAYLSDR005A



## Evaporator Fan Performance

**Table 4. Belt drive evaporator fan performance—5 tons—TSC060ED horizontal airflow (IP)**

External Static Pressure (Inches of Water)																					
		.10		.20		.30		.40		.50		.60		.70		.80		.90		1.00	
cfm	rpm	bhp	rpm	bhp	rpm	bhp	rpm	bhp	rpm	bhp	rpm	bhp	rpm	bhp	rpm	bhp	rpm	bhp	rpm	bhp	
<b>1.5-hp Std Motor &amp; Field Supplied Low Static Drive<sup>(a)</sup></b>																					
1600	—	—	—	—	731	0.33	786	0.38	837	0.43	890	0.48	939	0.54	982	0.60	1021	0.66	1057	0.72	
1800	—	—	720	0.35	780	0.41	833	0.48	881	0.54	926	0.59	974	0.65	1020	0.71	1062	0.78	1100	0.84	
2000	—	—	773	0.44	830	0.52	881	0.59	928	0.66	972	0.73	1013	0.80	1055	0.85	1098	0.91	1138	0.98	
2200	765	0.47	827	0.56	881	0.64	931	0.72	976	0.80	1019	0.87	1059	0.95	1097	1.02	1134	1.09	1172	1.14	
2400	823	0.60	881	0.69	934	0.78	981	0.87	1025	0.95	1067	1.04	1106	1.12	1144	1.21	1179	1.29	1213	1.37	
<b>1.5-hp Std Motor &amp; Drive</b>																					

Continued

External Static Pressure (Inches of Water)											
		1.10		1.20		1.30		1.40		1.50	
cfm	rpm	bhp	rpm	bhp	rpm	bhp	rpm	bhp	rpm	bhp	
<b>1.5-hp Std Motor &amp; Drive</b>											
1600	1093	0.78	1128	0.83	1161	0.90	1193	0.96	1226	1.03	
1800	1135	0.91	1168	0.98	1201	1.04	1231	1.11	1263	1.17	
2000	1176	1.06	1211	1.13	1243	1.20	1273	1.28	1303	1.35	
2200	1212	1.22	1249	1.30	1284	1.38	1315	1.46	1346	1.54	
2400	1247	1.43	1282	1.49	1318	1.58	1353	1.66	—	—	

**Notes:**

1. For Standard Evaporator Fan Speed (RPM), reference [Table 97, p. 117](#).
2. Data includes pressure drop due to standard filters and wet coils.
3. Refer to [Table 108, p. 119](#) to determine additional static pressure drop due to other options/accessories.
4. 1.5-hp Fan Motor Heat (MBh) = 2.720 x Fan bhp + 0.850
5. Factory supplied motors, in commercial equipment, are definite purpose motors, specifically designed and tested to operate reliably and continuously at all cataloged conditions. Using the full horsepower range of our fan motors as shown in our tabular data will not result in nuisance tripping or premature motor failure. Our product's warranty will not be affected.

(a) BAYLSDR005A

## Evaporator Fan Performance

**Table 5. Belt drive evaporator fan performance—5 tons—YSC060ED low gas heat—downflow airflow (SI)**

																						External Static Pressure (Pascals)									
		25		50		75		100		125		150		175		200		225		250											
m <sup>3</sup> /h	rpm	kW	rpm	kW	rpm	kW	rpm	kW	rpm	kW	rpm	kW	rpm	kW	rpm	kW	rpm	kW	rpm	kW											
<b>1.12 Nom kW Std Motor &amp; Field Supplied Low Static Drive<sup>(a)</sup></b>																															
2720	—	—	—	—	765	0.26	815	0.30	862	0.34	906	0.37	950	0.41	991	0.45	1031	0.49	1069	0.53											
3060	—	—	768	0.29	822	0.34	870	0.38	915	0.42	957	0.47	996	0.51	1034	0.55	1074	0.59	1110	0.64											
3400	771	0.32	829	0.37	880	0.42	926	0.47	969	0.52	1009	0.57	1047	0.62	1084	0.67	1119	0.71	1154	0.76											
3740	837	0.41	890	0.47	939	0.53	984	0.58	1026	0.64	1064	0.69	1101	0.75	1137	0.80	1170	0.85	1203	0.90											
4080	903	0.52	953	0.59	999	0.65	1043	0.71	1083	0.77	1120	0.83	1156	0.89	1190	0.95	1223	1.01	1255	1.07											
<b>1.12 Nom kW Standard Motor &amp; Drive</b>																															

Continued

												External Static Pressure (Pascals)				
		275		300		325		350		375						
m <sup>3</sup> /h	rpm	kW	rpm	kW	rpm	kW	rpm	kW	rpm	kW						
<b>1.12 Nom kW Standard Motor &amp; Drive</b>																
2720	1106	0.58	1141	0.62	1175	0.66	1208	0.70	1239	0.74						
3060	1147	0.68	1181	0.73	1214	0.78	1247	0.82	1277	0.87						
3400	1189	0.81	1222	0.86	1255	0.91	1286	0.96	1318	1.01						
3740	1235	0.95	1266	1.00	1297	1.06	1329	1.11	1359	1.17						
4080	1285	1.12	1315	1.18	1345	1.23	—	—	—	—						

**Notes:**

1. For Standard Evaporator Fan Speed (RPM), reference [Table 97, p. 117](#).
2. Data includes pressure drop due to standard filters and wet coils.
3. Refer to [Table 107, p. 119](#) to determine additional static pressure drop due to other options/accessories.
4. 1.12 kW Fan Motor Heat (MBh) = 1.070 x Fan kW + 0.250
5. Factory supplied motors, in commercial equipment, are definite purpose motors, specifically designed and tested to operate reliably and continuously at all cataloged conditions. Using the full horsepower range of our fan motors as shown in our tabular data will not result in nuisance tripping or premature motor failure. Our product's warranty will not be affected.

(a) BAYLSDR005A



## Evaporator Fan Performance

**Table 6. Belt drive evaporator fan performance—5 tons—YSC060ED low gas heat—downflow airflow (IP)**

cfm	External Static Pressure (Inches of Water)																			
	.10		.20		.30		.40		.50		.60		.70		.80		.90		1.00	
	rpm	bhp	rpm	bhp	rpm	bhp	rpm	bhp	rpm	bhp	rpm	bhp	rpm	bhp	rpm	bhp	rpm	bhp	rpm	bhp
<b>1.5-hp Std Motor &amp; Field Supplied Low Static Drive<sup>(a)</sup></b>																				
1600	—	—	—	—	765	0.35	815	0.40	862	0.45	906	0.50	950	0.55	991	0.61	1031	0.66	1069	0.72
1800	—	—	768	0.39	822	0.45	870	0.51	915	0.57	957	0.63	996	0.68	1034	0.73	1074	0.80	1110	0.86
2000	771	0.43	829	0.50	880	0.57	926	0.64	969	0.70	1009	0.77	1047	0.83	1084	0.89	1119	0.95	1154	1.02
2200	837	0.55	890	0.63	939	0.71	984	0.78	1026	0.86	1064	0.93	1101	1.00	1137	1.08	1170	1.14	1203	1.21
2400	903	0.70	953	0.79	999	0.87	1043	0.96	1083	1.04	1120	1.12	1156	1.20	1190	1.28	1223	1.36	1255	1.44
<b>1.5-hp Std Motor &amp; Drive</b>																				

Continued

cfm	External Static Pressure (Inches of Water)									
	1.10		1.20		1.30		1.40		1.50	
	rpm	bhp	rpm	bhp	rpm	bhp	rpm	bhp	rpm	bhp
<b>1.5-hp Std Motor &amp; Drive</b>										
1600	1106	0.77	1141	0.83	1175	0.88	1208	0.94	1239	0.99
1800	1147	0.92	1181	0.98	1214	1.04	1247	1.10	1277	1.17
2000	1189	1.08	1222	1.15	1255	1.22	1286	1.29	1318	1.36
2200	1235	1.28	1266	1.35	1297	1.42	1329	1.49	1359	1.57
2400	1285	1.51	1315	1.58	1345	1.65	—	—	—	—

**Notes:**

1. For Standard Evaporator Fan Speed (RPM), reference [Table 97, p. 117](#).
2. Data includes pressure drop due to standard filters and wet coils.
3. Refer to [Table 108, p. 119](#) to determine additional static pressure drop due to other options/accessories.
4. 1.5-hp Fan Motor Heat (MBh) = 2.720 x Fan bhp + 0.850
5. Factory supplied motors, in commercial equipment, are definite purpose motors, specifically designed and tested to operate reliably and continuously at all cataloged conditions. Using the full horsepower range of our fan motors as shown in our tabular data will not result in nuisance tripping or premature motor failure. Our product's warranty will not be affected.

(a) BAYLSDR005A

## Evaporator Fan Performance

**Table 7. Belt drive evaporator fan performance—5 tons—YSC060ED high gas heat—downflow airflow (SI)**

																						External Static Pressure (Pascals)									
		25		50		75		100		125		150		175		200		225		250											
m <sup>3</sup> /h	rpm	kW	rpm	kW	rpm	kW	rpm	kW	rpm	kW	rpm	kW	rpm	kW	rpm	kW	rpm	kW	rpm	kW											
<b>1.12 Nom kW Std Motor &amp; Field Supplied Low Static Drive<sup>(a)</sup></b>																															
2720	—	—	731	0.23	784	0.27	832	0.31	877	0.35	921	0.38	964	0.42	1004	0.46	1044	0.50	1082	0.54											
3060	738	0.25	795	0.30	845	0.35	891	0.39	933	0.44	975	0.48	1013	0.52	1052	0.56	1089	0.61	1126	0.65											
3400	808	0.33	860	0.39	908	0.44	952	0.49	992	0.54	1030	0.59	1068	0.64	1104	0.68	1139	0.73	1173	0.78											
3740	878	0.43	927	0.49	972	0.55	1014	0.60	1053	0.66	1089	0.72	1124	0.77	1158	0.83	1192	0.87	1224	0.93											
4080	948	0.55	995	0.61	1037	0.67	1077	0.74	1115	0.80	1150	0.86	1184	0.92	1216	0.98	1247	1.04	1279	1.10											
<b>1.12 Nom kW Standard Motor &amp; Drive</b>																															

**Continued**

												External Static Pressure (Pascals)				
		275		300		325		350		375						
m <sup>3</sup> /h	rpm	kW	rpm	kW	rpm	kW	rpm	kW	rpm	kW						
<b>1.12 Nom kW Standard Motor &amp; Drive</b>																
2720	1119	0.58	1154	0.63	1189	0.67	1222	0.71	1255	0.76						
3060	1162	0.70	1196	0.74	1228	0.79	1261	0.83	1293	0.88						
3400	1207	0.83	1239	0.88	1272	0.93	1304	0.98	1334	1.02						
3740	1257	0.98	1288	1.03	1318	1.09	1347	1.14	1378	1.19						
4080	1309	1.15	1339	1.21	1367	1.26	—	—	—	—						

**Notes:**

1. For Standard Evaporator Fan Speed (RPM), reference [Table 97, p. 117](#).
2. Data includes pressure drop due to standard filters and wet coils.
3. Refer to [Table 107, p. 119](#) to determine additional static pressure drop due to other options/accessories.
4. 1.12 kW Fan Motor Heat (MBh) = 1.070 x Fan kW + 0.250
5. Factory supplied motors, in commercial equipment, are definite purpose motors, specifically designed and tested to operate reliably and continuously at all cataloged conditions. Using the full horsepower range of our fan motors as shown in our tabular data will not result in nuisance tripping or premature motor failure. Our product's warranty will not be affected.

(a) BAYLSDR005A



## Evaporator Fan Performance

**Table 8. Belt drive evaporator fan performance—5 tons—YSC060ED high gas heat—downflow airflow (IP)**

External Static Pressure (Inches of Water)																					
		.10		.20		.30		.40		.50		.60		.70		.80		.90		1.00	
cfm	rpm	bhp	rpm	bhp	rpm	bhp	rpm	bhp	rpm	bhp	rpm	bhp	rpm	bhp	rpm	bhp	rpm	bhp	rpm	bhp	
<b>1.5-hp Std Motor &amp; Field Supplied Low Static Drive<sup>(a)</sup></b>																					
1600	—	—	731	0.31	784	0.36	832	0.41	877	0.46	921	0.51	964	0.57	1004	0.62	1044	0.67	1082	0.73	
1800	738	0.34	795	0.40	845	0.46	891	0.53	933	0.59	975	0.64	1013	0.70	1052	0.76	1089	0.82	1126	0.87	
2000	808	0.45	860	0.52	908	0.59	952	0.66	992	0.72	1030	0.79	1068	0.86	1104	0.92	1139	0.98	1173	1.05	
2200	878	0.58	927	0.66	972	0.73	1014	0.81	1053	0.89	1089	0.96	1124	1.04	1158	1.11	1192	1.17	1224	1.24	
2400	948	0.73	995	0.82	1037	0.90	1077	0.99	1115	1.07	1150	1.15	1184	1.24	1216	1.32	1247	1.40	1279	1.47	
<b>1.5-hp Std Motor &amp; Drive</b>																					

Continued

External Static Pressure (Inches of Water)											
		1.10		1.20		1.30		1.40		1.50	
cfm	rpm	bhp	rpm	bhp	rpm	bhp	rpm	bhp	rpm	bhp	
<b>1.5-hp Std Motor &amp; Drive</b>											
1600	1119	0.78	1154	0.84	1189	0.90	1222	0.96	1255	1.01	
1800	1162	0.93	1196	0.99	1228	1.05	1261	1.12	1293	1.18	
2000	1207	1.11	1239	1.18	1272	1.24	1304	1.31	1334	1.37	
2200	1257	1.31	1288	1.39	1318	1.46	1347	1.53	1378	1.60	
2400	1309	1.54	1339	1.62	1367	1.69	—	—	—	—	

**Notes:**

1. For Standard Evaporator Fan Speed (RPM), reference [Table 97, p. 117](#)
2. Data includes pressure drop due to standard filters and wet coils.
3. Refer to [Table 108, p. 119](#) to determine additional static pressure drop due to other options/accessories.
4. 1.5-hp Fan Motor Heat (MBh) = 2.720 x Fan bhp + 0.850
5. Factory supplied motors, in commercial equipment, are definite purpose motors, specifically designed and tested to operate reliably and continuously at all cataloged conditions. Using the full horsepower range of our fan motors as shown in our tabular data will not result in nuisance tripping or premature motor failure. Our product's warranty will not be affected.

(a) BAYLSDR005A



## Evaporator Fan Performance

**Table 9. Belt drive evaporator fan performance—5 tons—YSC060ED low gas heat—horizontal airflow (SI)**

																						External Static Pressure (Pascals)									
		25		50		75		100		125		150		175		200		225		250											
m <sup>3</sup> /h	rpm	kW	rpm	kW	rpm	kW	rpm	kW	rpm	kW	rpm	kW	rpm	kW	rpm	kW	rpm	kW	rpm	kW											
<b>1.12 Nom kW Std Motor &amp; Field Supplied Low Static Drive<sup>(a)</sup></b>																															
2720	—	—	—	—	764	0.26	818	0.30	867	0.34	912	0.38	955	0.42	994	0.46	1031	0.50	1064	0.54											
3060	—	—	759	0.29	818	0.33	870	0.38	918	0.43	962	0.47	1003	0.51	1043	0.56	1080	0.61	1114	0.65											
3400	753	0.31	817	0.37	873	0.42	923	0.47	969	0.53	1012	0.58	1052	0.63	1091	0.67	1127	0.72	1162	0.77											
3740	815	0.40	875	0.46	928	0.52	977	0.58	1022	0.64	1064	0.70	1104	0.76	1141	0.81	1177	0.86	1211	0.91											
4080	878	0.50	935	0.57	986	0.64	1033	0.71	1076	0.77	1117	0.84	1156	0.90	1192	0.96	1227	1.02	1261	1.08											
<b>1.12 Nom kW Standard Motor &amp; Drive</b>																															

Continued

												External Static Pressure (Pascals)				
		275		300		325		350		375						
m <sup>3</sup> /h	rpm	kW	rpm	kW	rpm	kW	rpm	kW	rpm	kW						
<b>1.12 Nom kW Standard Motor &amp; Drive</b>																
2720	1100	0.58	1135	0.63	1167	0.67	1200	0.72	1231	0.76						
3060	1147	0.69	1178	0.74	1209	0.78	1240	0.83	1270	0.88						
3400	1195	0.83	1227	0.88	1258	0.92	1286	0.97	1314	1.02						
3740	1244	0.97	1275	1.02	1306	1.08	1336	1.14	1364	1.19						
4080	1292	1.13	1324	1.19	1355	1.25	—	—	—	—						

**Notes:**

1. For Standard Evaporator Fan Speed (RPM), reference [Table 97, p. 117](#).
2. Data includes pressure drop due to standard filters and wet coils.
3. Refer to [Table 107, p. 119](#) to determine additional static pressure drop due to other options/accessories.
4. 1.12 kW Fan Motor Heat (MBh) = 1.070 x Fan kW + 0.250
5. Factory supplied motors, in commercial equipment, are definite purpose motors, specifically designed and tested to operate reliably and continuously at all cataloged conditions. Using the full horsepower range of our fan motors as shown in our tabular data will not result in nuisance tripping or premature motor failure. Our product's warranty will not be affected.

(a) BAYLSDR005A



## Evaporator Fan Performance

**Table 10. Belt drive evaporator fan performance—5 tons—YSC060ED low gas heat—horizontal airflow (IP)**

cfm	External Static Pressure (Inches of Water)																			
	.10		.20		.30		.40		.50		.60		.70		.80		.90		1.00	
	rpm	bhp	rpm	bhp	rpm	bhp	rpm	bhp	rpm	bhp	rpm	bhp	rpm	bhp	rpm	bhp	rpm	bhp	rpm	bhp
<b>1.5-hp Std Motor &amp; Field Supplied Low Static Drive<sup>(a)</sup></b>																				
1600	—	—	—	—	764	0.35	818	0.41	867	0.46	912	0.51	955	0.56	994	0.62	1031	0.67	1064	0.72
1800	—	—	759	0.38	818	0.45	870	0.51	918	0.57	962	0.63	1003	0.69	1043	0.75	1080	0.81	1114	0.87
2000	753	0.41	817	0.49	873	0.57	923	0.64	969	0.71	1012	0.77	1052	0.84	1091	0.90	1127	0.97	1162	1.04
2200	815	0.53	875	0.62	928	0.70	977	0.78	1022	0.86	1064	0.94	1104	1.01	1141	1.09	1177	1.16	1211	1.22
2400	878	0.68	935	0.77	986	0.86	1033	0.95	1076	1.04	1117	1.12	1156	1.20	1192	1.29	1227	1.37	1261	1.45
<b>1.5-hp Std Motor &amp; Drive</b>																				

Continued

cfm	External Static Pressure (Inches of Water)									
	1.10		1.20		1.30		1.40		1.50	
	rpm	bhp	rpm	bhp	rpm	bhp	rpm	bhp	rpm	bhp
<b>1.5-hp Std Motor &amp; Drive</b>										
1600	1100	0.78	1135	0.84	1167	0.90	1200	0.96	1231	1.02
1800	1147	0.93	1178	0.99	1209	1.05	1240	1.12	1270	1.18
2000	1195	1.11	1227	1.17	1258	1.24	1286	1.30	1314	1.37
2200	1244	1.30	1275	1.37	1306	1.45	1336	1.53	1364	1.60
2400	1292	1.52	1324	1.60	1355	1.68	—	—	—	—

**Notes:**

1. For Standard Evaporator Fan Speed (RPM), reference [Table 97, p. 117](#).
2. Data includes pressure drop due to standard filters and wet coils.
3. Refer to [Table 107, p. 119](#) to determine additional static pressure drop due to other options/accessories.
4. 1.5-hp Fan Motor Heat (MBh) = 2.720 x Fan bhp + 0.850
5. Factory supplied motors, in commercial equipment, are definite purpose motors, specifically designed and tested to operate reliably and continuously at all cataloged conditions. Using the full horsepower range of our fan motors as shown in our tabular data will not result in nuisance tripping or premature motor failure. Our product's warranty will not be affected.

(a) BAYLSDR005A

## Evaporator Fan Performance

**Table 11. Belt drive evaporator fan performance—5 tons—YSC060ED high gas heat—horizontal airflow (SI)**

																						External Static Pressure (Pascals)									
		25		50		75		100		125		150		175		200		225		250											
m <sup>3</sup> /h	rpm	kW	rpm	kW	rpm	kW	rpm	kW	rpm	kW	rpm	kW	rpm	kW	rpm	kW	rpm	kW	rpm	kW											
<b>1.12 Nom kW Std Motor &amp; Field Supplied Low Static Drive<sup>(a)</sup></b>																															
2720	—	—	—	—	777	0.27	831	0.31	879	0.35	922	0.39	966	0.43	1009	0.47	1047	0.51	1085	0.55											
3060	—	—	772	0.29	831	0.34	884	0.39	932	0.44	974	0.48	1015	0.53	1053	0.56	1093	0.61	1130	0.66											
3400	767	0.32	831	0.38	887	0.43	938	0.49	985	0.54	1029	0.59	1067	0.64	1106	0.69	1141	0.74	1175	0.78											
3740	830	0.41	891	0.47	945	0.54	994	0.60	1040	0.66	1082	0.71	1122	0.77	1158	0.83	1193	0.88	1227	0.94											
4080	894	0.52	951	0.59	1003	0.66	1050	0.72	1095	0.79	1136	0.85	1175	0.92	1212	0.98	1247	1.04	1278	1.10											
<b>1.12 Nom kW Standard Motor &amp; Drive</b>																															

Continued

												External Static Pressure (Pascals)				
		275		300		325		350		375						
m <sup>3</sup> /h	rpm	kW	rpm	kW	rpm	kW	rpm	kW	rpm	kW						
<b>1.12 Nom kW Standard Motor &amp; Drive</b>																
2720	1122	0.59	1157	0.64	1190	0.68	1221	0.73	1252	0.77						
3060	1165	0.70	1198	0.75	1232	0.80	1264	0.85	1296	0.90						
3400	1210	0.83	1244	0.89	1277	0.94	1307	0.99	1337	1.04						
3740	1258	0.99	1289	1.03	1322	1.09	1353	1.15	1383	1.21						
4080	1310	1.16	1342	1.23	1370	1.28	—	—	—	—						

**Notes:**

1. For Standard Evaporator Fan Speed (RPM), reference [Table 97, p. 117](#).
2. Data includes pressure drop due to standard filters and wet coils.
3. Refer to [Table 107, p. 119](#) to determine additional static pressure drop due to other options/accessories.
4. 1.12 kW Fan Motor Heat (MBh) = 1.070 x Fan kW + 0.250
5. Factory supplied motors, in commercial equipment, are definite purpose motors, specifically designed and tested to operate reliably and continuously at all cataloged conditions. Using the full horsepower range of our fan motors as shown in our tabular data will not result in nuisance tripping or premature motor failure. Our product's warranty will not be affected.

(a) BAYLSDR005A



## Evaporator Fan Performance

**Table 12. Belt drive evaporator fan performance—5 tons—YSC060ED high gas heat—horizontal airflow (IP)**

cfm	External Static Pressure (Inches of Water)																			
	.10		.20		.30		.40		.50		.60		.70		.80		.90		1.00	
	rpm	bhp	rpm	bhp	rpm	bhp	rpm	bhp	rpm	bhp	rpm	bhp	rpm	bhp	rpm	bhp	rpm	bhp	rpm	bhp
<b>1.5-hp Std Motor &amp; Field Supplied Low Static Drive<sup>(a)</sup></b>																				
1600	—	—	—	—	777	0.36	831	0.41	879	0.47	922	0.52	966	0.57	1009	0.63	1047	0.68	1085	0.74
1800	—	—	772	0.39	831	0.46	884	0.52	932	0.59	974	0.64	1015	0.70	1053	0.76	1093	0.82	1130	0.88
2000	767	0.43	831	0.50	887	0.58	938	0.65	985	0.72	1029	0.79	1067	0.86	1106	0.93	1141	0.99	1175	1.05
2200	830	0.55	891	0.63	945	0.72	994	0.80	1040	0.88	1082	0.96	1122	1.04	1158	1.11	1193	1.18	1227	1.26
2400	894	0.69	951	0.79	1003	0.88	1050	0.97	1095	1.06	1136	1.15	1175	1.23	1212	1.32	1247	1.40	1278	1.47
<b>1.5-hp Std Motor &amp; Drive</b>																				

Continued

cfm	External Static Pressure (Inches of Water)									
	1.10		1.20		1.30		1.40		1.50	
	rpm	bhp	rpm	bhp	rpm	bhp	rpm	bhp	rpm	bhp
<b>1.5-hp Std Motor &amp; Drive</b>										
1600	1122	0.79	1157	0.86	1190	0.92	1221	0.97	1252	1.04
1800	1165	0.94	1198	1.00	1232	1.07	1264	1.14	1296	1.21
2000	1210	1.12	1244	1.19	1277	1.26	1307	1.32	1337	1.39
2200	1258	1.32	1289	1.39	1322	1.47	1353	1.54	1383	1.62
2400	1310	1.56	1342	1.64	1370	1.71	—	—	—	—

**Notes:**

1. For Standard Evaporator Fan Speed (RPM), reference [Table 97, p. 117](#).
2. Data includes pressure drop due to standard filters and wet coils.
3. Refer to [Table 108, p. 119](#) to determine additional static pressure drop due to other options/accessories.
4. 1.5-hp Fan Motor Heat (MBh) = 2.720 x Fan bhp + 0.850
5. Factory supplied motors, in commercial equipment, are definite purpose motors, specifically designed and tested to operate reliably and continuously at all cataloged conditions. Using the full horsepower range of our fan motors as shown in our tabular data will not result in nuisance tripping or premature motor failure. Our product's warranty will not be affected.

(a) BAYLSDR005A

## Evaporator Fan Performance

**Table 13. Belt drive evaporator fan performance—5 tons—WSC060ED—downflow airflow (SI)**

																						External Static Pressure (Pascals)									
		25		50		75		100		125		150		175		200		225		250											
m <sup>3</sup> /h	rpm	kW	rpm	kW	rpm	kW	rpm	kW	rpm	kW	rpm	kW	rpm	kW	rpm	kW	rpm	kW	rpm	kW											
<b>1.12 Nom kW Std Motor &amp; Field Supplied Low Static Drive<sup>(a)</sup></b>																															
2720	—	—	—	—	—	—	773	0.26	823	0.30	872	0.34	924	0.38	977	0.43	1021	0.48	1061	0.52											
3060	—	—	—	—	765	0.29	818	0.33	867	0.37	912	0.41	955	0.45	999	0.50	1045	0.55	1092	0.61											
3400	—	—	755	0.31	812	0.36	864	0.41	912	0.46	956	0.50	997	0.55	1037	0.59	1075	0.64	1116	0.70											
3740	743	0.33	806	0.39	861	0.45	911	0.50	958	0.56	1001	0.61	1042	0.66	1080	0.71	1116	0.76	1151	0.81											
4080	798	0.42	858	0.49	912	0.55	960	0.61	1005	0.67	1047	0.73	1087	0.78	1125	0.84	1160	0.89	1194	0.94											
<b>1.12 Nom kW Standard Motor &amp; Drive</b>																															

**Continued**

												External Static Pressure (Pascals)				
		275		300		325		350		375						
m <sup>3</sup> /h	rpm	kW	rpm	kW	rpm	kW	rpm	kW	rpm	kW						
<b>1.12 Nom kW Standard Motor &amp; Drive</b>																
2720	1097	0.56	1134	0.60	1167	0.64	1201	0.69	1232	0.73						
3060	1134	0.66	1171	0.71	1205	0.76	1237	0.80	1270	0.85						
3400	1157	0.75	1200	0.81	1240	0.87	1275	0.93	1307	0.98						
3740	1187	0.86	1223	0.92	1261	0.98	1300	1.04	1338	1.11						
4080	1226	1.00	1260	1.05	1292	1.11	1325	1.18	1358	1.24						

**Notes:**

1. For Standard Evaporator Fan Speed (RPM), reference [Table 101, p. 117](#).
2. Data includes pressure drop due to standard filters and wet coils.
3. Refer to [Table 109, p. 120](#) to determine additional static pressure drop due to other options/accessories.
4. 1.12 kW Fan Motor Heat (MBh) = 1.070 x Fan kW + 0.250
5. Factory supplied motors, in commercial equipment, are definite purpose motors, specifically designed and tested to operate reliably and continuously at all cataloged conditions. Using the full horsepower range of our fan motors as shown in our tabular data will not result in nuisance tripping or premature motor failure. Our product's warranty will not be affected.

(a) BAYLSDR005A



## Evaporator Fan Performance

**Table 14. Belt drive evaporator fan performance—5 tons—WSC060ED—downflow airflow (IP)**

cfm	External Static Pressure (Inches of Water)																				
	.10		.20		.30		.40		.50		.60		.70		.80		.90		1.00		
	rpm	bhp	rpm	bhp	rpm	bhp	rpm	bhp	rpm	bhp	rpm	bhp	rpm	bhp	rpm	bhp	rpm	bhp	rpm	bhp	
<b>1.5-hp Std Motor &amp; Field Supplied Low Static Drive<sup>(a)</sup></b>																					
1600	—	—	—	—	—	—	—	773	0.35	823	0.40	872	0.45	924	0.51	977	0.58	1021	0.64	1061	0.70
1800	—	—	—	—	765	0.39	818	0.45	867	0.50	912	0.55	955	0.61	999	0.67	1045	0.74	1092	0.81	
2000	—	—	755	0.42	812	0.49	864	0.55	912	0.61	956	0.68	997	0.74	1037	0.80	1075	0.86	1116	0.93	
2200	743	0.45	806	0.53	861	0.60	911	0.67	958	0.75	1001	0.81	1042	0.88	1080	0.95	1116	1.01	1151	1.08	
2400	798	0.56	858	0.65	912	0.74	960	0.82	1005	0.89	1047	0.97	1087	1.05	1125	1.12	1160	1.19	1194	1.27	
<b>1.5-hp Std Motor &amp; Drive</b>																					

Continued

cfm	External Static Pressure (Inches of Water)									
	1.10		1.20		1.30		1.40		1.50	
	rpm	bhp	rpm	bhp	rpm	bhp	rpm	bhp	rpm	bhp
<b>1.5-hp Std Motor &amp; Drive</b>										
1600	1097	0.75	1134	0.81	1167	0.86	1201	0.92	1232	0.98
1800	1134	0.88	1171	0.95	1205	1.02	1237	1.08	1270	1.14
2000	1157	1.01	1200	1.09	1240	1.17	1275	1.25	1307	1.32
2200	1187	1.15	1223	1.23	1261	1.32	1300	1.40	1338	1.49
2400	1226	1.34	1260	1.41	1292	1.49	1325	1.58	1358	1.66

**Notes:**

1. For Standard Evaporator Fan Speed (RPM), reference [Table 101, p. 117](#).
2. Data includes pressure drop due to standard filters and wet coils.
3. Refer to [Table 110, p. 120](#) to determine additional static pressure drop due to other options/accessories.
4. 1.5-hp Fan Motor Heat (MBh) = 2.720 x Fan bhp + 0.850
5. Factory supplied motors, in commercial equipment, are definite purpose motors, specifically designed and tested to operate reliably and continuously at all cataloged conditions. Using the full horsepower range of our fan motors as shown in our tabular data will not result in nuisance tripping or premature motor failure. Our product's warranty will not be affected.

(a) BAYLSDR005A

## Evaporator Fan Performance

**Table 15. Belt drive evaporator fan performance—5 tons—WSC060EDhorizontal airflow (SI)**

																						External Static Pressure (Pascals)									
		25		50		75		100		125		150		175		200		225		250											
m <sup>3</sup> /h	rpm	kW	rpm	kW	rpm	kW	rpm	kW	rpm	kW	rpm	kW	rpm	kW	rpm	kW	rpm	kW	rpm	kW											
<b>1.12 Nom kW Std Motor &amp; Field Supplied Low Static Drive<sup>(a)</sup></b>																															
2720	—	—	—	—	731	0.24	786	0.28	837	0.32	890	0.36	939	0.40	982	0.45	1021	0.49	1057	0.53											
3060	—	—	720	0.26	780	0.31	833	0.36	881	0.40	926	0.44	974	0.48	1020	0.53	1062	0.58	1100	0.63											
3400	—	—	773	0.33	830	0.39	881	0.44	928	0.49	972	0.54	1013	0.59	1055	0.63	1098	0.68	1138	0.73											
3740	765	0.35	827	0.42	881	0.48	931	0.54	976	0.59	1019	0.65	1059	0.71	1097	0.76	1134	0.81	1172	0.85											
4080	823	0.44	881	0.51	934	0.58	981	0.65	1025	0.71	1067	0.77	1106	0.84	1144	0.90	1179	0.96	1213	1.02											
<b>1.12 Nom kW Standard Motor &amp; Drive</b>																															

**Continued**

												External Static Pressure (Pascals)				
		275		300		325		350		375						
m <sup>3</sup> /h	rpm	kW	rpm	kW	rpm	kW	rpm	kW	rpm	kW						
<b>1.12 Nom kW Standard Motor &amp; Drive</b>																
2720	1093	0.58	1128	0.62	1161	0.67	1193	0.72	1226	0.77						
3060	1135	0.68	1168	0.73	1201	0.78	1231	0.83	1263	0.88						
3400	1176	0.79	1211	0.84	1243	0.90	1273	0.95	1303	1.01						
3740	1212	0.91	1249	0.97	1284	1.03	1315	1.09	1346	1.15						
4080	1247	1.07	1282	1.11	1318	1.18	1353	1.24	—	—						

**Notes:**

1. For Standard Evaporator Fan Speed (RPM), reference [Table 101, p. 117](#).
2. Data includes pressure drop due to standard filters and wet coils.
3. Refer to [Table 109, p. 120](#) to determine additional static pressure drop due to other options/accessories.
4. 1.12 kW Fan Motor Heat (MBh) = 1.070 x Fan kW + 0.250
5. Factory supplied motors, in commercial equipment, are definite purpose motors, specifically designed and tested to operate reliably and continuously at all cataloged conditions. Using the full horsepower range of our fan motors as shown in our tabular data will not result in nuisance tripping or premature motor failure. Our product's warranty will not be affected.

(a) BAYLSDR005A



## Evaporator Fan Performance

**Table 16. Belt drive evaporator fan performance—5 tons—WSC060ED—horizontal airflow (IP)**

cfm	External Static Pressure (Inches of Water)																			
	.10		.20		.30		.40		.50		.60		.70		.80		.90		1.00	
	rpm	bhp	rpm	bhp	rpm	bhp	rpm	bhp	rpm	bhp	rpm	bhp	rpm	bhp	rpm	bhp	rpm	bhp	rpm	bhp
<b>1.5-hp Std Motor &amp; Field Supplied Low Static Drive<sup>(a)</sup></b>																				
1600	—	—	—	—	731	0.33	786	0.38	837	0.43	890	0.48	939	0.54	982	0.60	1021	0.66	1057	0.72
1800	—	—	720	0.35	780	0.41	833	0.48	881	0.54	926	0.59	974	0.65	1020	0.71	1062	0.78	1100	0.84
2000	—	—	773	0.44	830	0.52	881	0.59	928	0.66	972	0.73	1013	0.80	1055	0.85	1098	0.91	1138	0.98
2200	765	0.47	827	0.56	881	0.64	931	0.72	976	0.80	1019	0.87	1059	0.95	1097	1.02	1134	1.09	1172	1.14
2400	823	0.60	881	0.69	934	0.78	981	0.87	1025	0.95	1067	1.04	1106	1.12	1144	1.21	1179	1.29	1213	1.37
<b>1.5-hp Std Motor &amp; Drive</b>																				

Continued

cfm	External Static Pressure (Inches of Water)									
	1.10		1.20		1.30		1.40		1.50	
	rpm	bhp	rpm	bhp	rpm	bhp	rpm	bhp	rpm	bhp
<b>1.5-hp Std Motor &amp; Drive</b>										
1600	1093	0.78	1128	0.83	1161	0.90	1193	0.96	1226	1.03
1800	1135	0.91	1168	0.98	1201	1.04	1231	1.11	1263	1.17
2000	1176	1.06	1211	1.13	1243	1.20	1273	1.28	1303	1.35
2200	1212	1.22	1249	1.30	1284	1.38	1315	1.46	1346	1.54
2400	1247	1.43	1282	1.49	1318	1.58	1353	1.66	—	—

**Notes:**

1. For Standard Evaporator Fan Speed (RPM), reference [Table 101, p. 117](#).
2. Data includes pressure drop due to standard filters and wet coils.
3. Refer to [Table 110, p. 120](#) to determine additional static pressure drop due to other options/accessories.
4. 1.5-hp Fan Motor Heat (MBh) = 2.720 x Fan bhp + 0.850
5. Factory supplied motors, in commercial equipment, are definite purpose motors, specifically designed and tested to operate reliably and continuously at all cataloged conditions. Using the full horsepower range of our fan motors as shown in our tabular data will not result in nuisance tripping or premature motor failure. Our product's warranty will not be affected.

(a) BAYLSDR005A



## Evaporator Fan Performance

**Table 17. Belt drive evaporator fan performance—6 tons—TSC072ED—downflow airflow (SI)**

																						External Static Pressure (Pascals)									
		25		50		75		100		125		150		175		200		225		250											
m <sup>3</sup> /h	rpm	kW	rpm	kW	rpm	kW	rpm	kW	rpm	kW	rpm	kW	rpm	kW	rpm	kW	rpm	kW	rpm	kW											
<b>1.12 Nom kW Std Motor &amp; Field Supplied Low Static Drive<sup>(a)</sup></b>																															
3260	—	—	560	0.20	616	0.23	669	0.27	719	0.31	763	0.35	806	0.39	844	0.43	882	0.47	918	0.51											
3670	—	—	601	0.26	654	0.30	703	0.34	750	0.39	794	0.43	836	0.48	874	0.52	911	0.56	946	0.61											
4080	591	0.28	645	0.33	694	0.38	740	0.42	784	0.47	826	0.52	867	0.57	905	0.62	941	0.67	976	0.72											
4490	638	0.37	690	0.42	735	0.47	779	0.52	820	0.57	861	0.63	898	0.68	937	0.73	972	0.79	1007	0.84											
4890	687	0.46	735	0.52	779	0.58	820	0.63	859	0.69	897	0.75	933	0.80	969	0.86	1004	0.92	1038	0.98											
<b>1.12 Nom kW Standard Motor &amp; Drive</b>																															

Continued

																						External Static Pressure (Pascals)									
		275		300		325		350		375		400		425		450		475		500											
m <sup>3</sup> /h	rpm	kW	rpm	kW	rpm	kW	rpm	kW	rpm	kW	rpm	kW	rpm	kW	rpm	kW	rpm	kW	rpm	kW											
<b>1.12 Nom kW Standard Motor &amp; Drive</b>																															
1920	953	0.55	985	0.59	1017	0.63	1048	0.67	1076	0.71	1104	0.74	1133	0.78	1159	0.82	1186	0.86	1211	0.90											
2160	980	0.65	1012	0.70	1044	0.74	1074	0.79	1103	0.83	1132	0.87	1159	0.92	1186	0.96	1211	1.00	—	—											
2400	1009	0.77	1041	0.82	1071	0.86	1101	0.91	1131	0.97	1157	1.01	1185	1.06	1212	1.11	—	—	—	—											
2640	1039	0.90	1071	0.95	1100	1.00	1130	1.06	1159	1.11	1186	1.17	1213	1.22	—	—	—	—	—	—											
2880	1069	1.04	1101	1.10	1131	1.16	1160	1.22	1187	1.28	1215	1.34	—	—	—	—	—	—	—	—											
<b>1.12 Nom kW Standard Motor &amp; Field Supplied High Static Drive<sup>(b)</sup></b>																															

**Notes:**

1. For Standard Evaporator Fan Speed (RPM), reference [Table 97, p. 117](#).
2. Data includes pressure drop due to standard filters and wet coils.
3. Refer to [Table 107, p. 119](#) to determine additional static pressure drop due to other options/accessories.
4. 1.12 kW Fan Motor Heat (MBh) = 1.070 x Fan kW + 0.250
5. Factory supplied motors, in commercial equipment, are definite purpose motors, specifically designed and tested to operate reliably and continuously at all cataloged conditions. Using the full horsepower range of our fan motors as shown in our tabular data will not result in nuisance tripping or premature motor failure. Our product's warranty will not be affected.

(a) BAYLSDR005A  
(b) BAYHSDR013A



## Evaporator Fan Performance

**Table 18. Belt drive evaporator fan performance—6 tons—TSC072ED—downflow airflow (IP)**

External Static Pressure (Inches of Water)																					
		.10		.20		.30		.40		.50		.60		.70		.80		.90		1.00	
cfm	rpm	bhp	rpm	bhp	rpm	bhp	rpm	bhp	rpm	bhp	rpm	bhp	rpm	bhp	rpm	bhp	rpm	bhp	rpm	bhp	
<b>1.5-hp Std Motor &amp; Field Supplied Low Static Drive<sup>(a)</sup></b>																					
1920	—	—	560	0.26	616	0.31	669	0.37	719	0.42	763	0.47	806	0.52	844	0.58	882	0.63	918	0.68	
2160	—	—	601	0.34	654	0.40	703	0.46	750	0.52	794	0.58	836	0.64	874	0.70	911	0.76	946	0.81	
2400	591	0.38	645	0.44	694	0.50	740	0.57	784	0.63	826	0.70	867	0.76	905	0.83	941	0.90	976	0.96	
2640	638	0.49	690	0.56	735	0.63	779	0.70	820	0.77	861	0.84	898	0.91	937	0.98	972	1.06	1007	1.13	
2880	687	0.62	735	0.70	779	0.77	820	0.85	859	0.92	897	1.00	933	1.08	969	1.16	1004	1.23	1038	1.31	
<b>1.5-hp Std Motor &amp; Drive</b>																					

Continued

External Static Pressure (Inches of Water)																					
		1.10		1.20		1.30		1.40		1.50		1.60		1.70		1.80		1.90		2.00	
cfm	rpm	bhp	rpm	bhp	rpm	bhp	rpm	bhp	rpm	bhp	rpm	bhp	rpm	bhp	rpm	bhp	rpm	bhp	rpm	bhp	
<b>1.5-hp Std Motor &amp; Drive</b>																					
1920	953	0.74	985	0.79	1017	0.84	1048	0.89	1076	0.95	1104	1.00	1133	1.05	1159	1.10	1186	1.15	1211	1.20	
2160	980	0.87	1012	0.93	1044	0.99	1074	1.05	1103	1.11	1132	1.17	1159	1.23	1186	1.29	1211	1.35	—	—	
2400	1009	1.03	1041	1.09	1071	1.16	1101	1.22	1131	1.29	1157	1.36	1185	1.43	1212	1.49	—	—	—	—	
2640	1039	1.20	1071	1.27	1100	1.35	1130	1.42	1159	1.49	1186	1.56	1213	1.64	—	—	—	—	—	—	
2880	1069	1.39	1101	1.48	1131	1.55	1160	1.63	1187	1.71	1215	1.79	—	—	—	—	—	—	—	—	
<b>1.5-hp Std Motor &amp; Field Supplied High Static Drive<sup>(b)</sup></b>																					

**Notes:**

1. For Standard Evaporator Fan Speed (RPM), reference [Table 97, p. 117](#).
2. Data includes pressure drop due to standard filters and wet coils.
3. Refer to [Table 108, p. 119](#) to determine additional static pressure drop due to other options/accessories.
4. 1.5-hp Fan Motor Heat (MBh) = 2.720 x Fan bhp + 0.850
5. Factory supplied motors, in commercial equipment, are definite purpose motors, specifically designed and tested to operate reliably and continuously at all cataloged conditions. Using the full horsepower range of our fan motors as shown in our tabular data will not result in nuisance tripping or premature motor failure. Our product's warranty will not be affected.

(a) BAYLSDR005A  
(b) BAYHSDR013A

## Evaporator Fan Performance

**Table 19. Belt drive evaporator fan performance—6 tons—TSC072ED—horizontal airflow (SI)**

																						External Static Pressure (Pascals)									
		25		50		75		100		125		150		175		200		225		250											
m <sup>3</sup> /h	rpm	kW	rpm	kW	rpm	kW	rpm	kW	rpm	kW	rpm	kW	rpm	kW	rpm	kW	rpm	kW	rpm	kW											
<b>1.12 Nom kW Std Motor &amp; Field Supplied Low Static Drive<sup>(a)</sup></b>											<b>1.12 Nom kW Std Motor &amp; Drive</b>																				
3260	559	0.19	618	0.23	675	0.27	730	0.32	786	0.36	841	0.42	889	0.47	935	0.52	978	0.57	1018	0.62											
3670	615	0.26	667	0.30	719	0.35	770	0.40	818	0.44	868	0.50	917	0.56	963	0.62	1006	0.68	1047	0.73											
4080	671	0.35	720	0.40	766	0.45	813	0.50	858	0.55	901	0.60	945	0.66	991	0.73	1033	0.79	1076	0.86											
4490	728	0.45	774	0.51	815	0.56	859	0.61	901	0.67	941	0.72	981	0.78	1021	0.85	1062	0.92	1103	0.99											
4890	786	0.58	829	0.63	868	0.69	906	0.75	946	0.81	985	0.87	1022	0.93	1058	1.00	1095	1.06	1133	1.14											
<b>1.12 Nom kW Standard Motor &amp; Field Supplied High Static Drive<sup>(b)</sup></b>																															

Continued

																						External Static Pressure (Pascals)									
		275		300		325		350		375		400		425		450		475		500											
m <sup>3</sup> /h	rpm	kW	rpm	kW	rpm	kW	rpm	kW	rpm	kW	rpm	kW	rpm	kW	rpm	kW	rpm	kW	rpm	kW											
<b>1.12 Nom kW Motor &amp; Drive</b>																															
3260	1058	0.67	1096	0.72	1130	0.77	1165	0.82	1198	0.87	—	—	—	—	—	—	—	—	—	—											
3670	1086	0.79	1123	0.85	1157	0.90	1193	0.96	—	—	—	—	—	—	—	—	—	—	—	—											
4080	1114	0.92	1150	0.99	1187	1.05	1221	1.12	—	—	—	—	—	—	—	—	—	—	—	—											
4490	1142	1.06	1179	1.13	1214	1.21	—	—	—	—	—	—	—	—	—	—	—	—	—	—											
4890	1169	1.21	1207	1.29	—	—	—	—	—	—	—	—	—	—	—	—	—	—	—	—											
<b>1.12 Nom kW Standard Motor &amp; Field Supplied High Static Drive</b>																															

**Notes:**

1. For Standard Evaporator Fan Speed (RPM), reference [Table 97, p. 117](#).
2. Data includes pressure drop due to standard filters and wet coils.
3. Refer to [Table 107, p. 119](#) to determine additional static pressure drop due to other options/accessories.
4. 1.12 kW Fan Motor Heat (MBh) = 1.070 x Fan kW + 0.250
5. Factory supplied motors, in commercial equipment, are definite purpose motors, specifically designed and tested to operate reliably and continuously at all cataloged conditions. Using the full horsepower range of our fan motors as shown in our tabular data will not result in nuisance tripping or premature motor failure. Our product's warranty will not be affected.

(a) BAYLSDR005A  
(b) BAYHSDR013A



## Evaporator Fan Performance

**Table 20. Belt drive evaporator fan performance—6 tons—TSC072ED—horizontal airflow (IP)**

External Static Pressure (Inches of Water)																					
		.10		.20		.30		.40		.50		.60		.70		.80		.90		1.00	
cfm	rpm	bhp	rpm	bhp	rpm	bhp	rpm	bhp	rpm	bhp	rpm	bhp	rpm	bhp	rpm	bhp	rpm	bhp	rpm	bhp	
<b>1.5-hp Std Motor &amp; Field Supplied Low Static Drive<sup>(a)</sup></b>											<b>1.5-hp Std Motor &amp; Drive</b>										
1920	559	0.26	618	0.31	675	0.36	730	0.42	786	0.49	841	0.56	889	0.63	935	0.70	978	0.77	1018	0.83	
2160	615	0.35	667	0.41	719	0.47	770	0.53	818	0.60	868	0.67	917	0.75	963	0.83	1006	0.91	1047	0.98	
2400	671	0.47	720	0.53	766	0.60	813	0.66	858	0.73	901	0.81	945	0.88	991	0.97	1033	1.06	1076	1.15	
2640	728	0.61	774	0.68	815	0.75	859	0.82	901	0.90	941	0.97	981	1.05	1021	1.14	1062	1.23	1103	1.33	
2880	786	0.77	829	0.85	868	0.93	906	1.00	946	1.09	985	1.17	1022	1.25	1058	1.33	1095	1.43	1133	1.52	
											<b>1.5-hp Std Motor &amp; Field Supplied High Static Drive<sup>(b)</sup></b>										

Continued

External Static Pressure (Inches of Water)																					
		1.10		1.20		1.30		1.40		1.50		1.60		1.70		1.80		1.90		2.00	
cfm	rpm	bhp	rpm	bhp	rpm	bhp	rpm	bhp	rpm	bhp	rpm	bhp	rpm	bhp	rpm	bhp	rpm	bhp	rpm	bhp	
<b>1.5-hp Std Motor &amp; Drive</b>																					
1920	1058	0.90	1096	0.97	1130	1.03	1165	1.10	1198	1.17	—	—	—	—	—	—	—	—	—	—	
2160	1086	1.06	1123	1.14	1157	1.21	1193	1.29	—	—	—	—	—	—	—	—	—	—	—	—	
2400	1114	1.24	1150	1.32	1187	1.41	1221	1.49	—	—	—	—	—	—	—	—	—	—	—	—	
2640	1142	1.43	1179	1.52	1214	1.62	—	—	—	—	—	—	—	—	—	—	—	—	—	—	
2880	1169	1.63	1207	1.73	—	—	—	—	—	—	—	—	—	—	—	—	—	—	—	—	
<b>1.5-hp Std Motor &amp; Field Supplied High Static Drive</b>																					

**Notes:**

1. For Standard Evaporator Fan Speed (RPM), reference [Table 97, p. 117](#).
2. Data includes pressure drop due to standard filters and wet coils.
3. Refer to [Table 108, p. 119](#) to determine additional static pressure drop due to other options/accessories.
4. 1.5-hp Fan Motor Heat (MBh) = 2.720 x Fan bhp + 0.850
5. Factory supplied motors, in commercial equipment, are definite purpose motors, specifically designed and tested to operate reliably and continuously at all cataloged conditions. Using the full horsepower range of our fan motors as shown in our tabular data will not result in nuisance tripping or premature motor failure. Our product's warranty will not be affected.

(a) BAYLSDR005A  
(b) BAYHSDR013A

## Evaporator Fan Performance

**Table 21. Belt drive evaporator fan performance—6 tons—YSC072ED—low gas heat—downflow airflow (SI)**

																						External Static Pressure (Pascals)									
		25		50		75		100		125		150		175		200		225		250											
m <sup>3</sup> /h	rpm	kW	rpm	kW	rpm	kW	rpm	kW	rpm	kW	rpm	kW	rpm	kW	rpm	kW	rpm	kW	rpm	kW											
<b>1.12 Nom kW Std Motor &amp; Field Supplied Low Static Drive<sup>(a)</sup></b>											<b>1.12 Nom kW Std Motor &amp; Drive</b>																				
3260	—	—	596	0.22	653	0.26	706	0.30	753	0.34	797	0.39	839	0.43	877	0.47	914	0.51	948	0.55											
3670	587	0.24	643	0.29	695	0.33	745	0.38	791	0.43	834	0.47	873	0.52	912	0.57	949	0.62	983	0.66											
4080	639	0.32	691	0.37	740	0.42	785	0.47	830	0.52	872	0.58	911	0.63	948	0.68	983	0.74	1017	0.79											
4490	693	0.42	741	0.47	786	0.53	829	0.58	870	0.64	911	0.70	950	0.75	985	0.81	1021	0.87	1054	0.93											
4890	747	0.53	792	0.59	834	0.65	875	0.71	914	0.77	952	0.83	989	0.89	1024	0.96	1059	1.02	1092	1.08											
											<b>1.12 Nom kW Standard Motor &amp; Field Supplied High Static Drive</b>																				

Continued

																						External Static Pressure (Pascals)									
		275		300		325		350		375		400		425		450		475		500											
m <sup>3</sup> /h	rpm	kW	rpm	kW	rpm	kW	rpm	kW	rpm	kW	rpm	kW	rpm	kW	rpm	kW	rpm	kW	rpm	kW											
<b>1.12 Nom kW Standard Motor &amp; Drive</b>											<b>1.12 Nom kW Standard Motor &amp; Field Supplied High Static Drive<sup>(b)</sup></b>																				
3260	980	0.59	1012	0.63	1042	0.67	1071	0.70	1100	0.74	1127	0.78	1153	0.82	1179	0.86	1205	0.89	—	—											
3670	1014	0.71	1046	0.75	1076	0.79	1104	0.84	1133	0.88	1160	0.93	1187	0.97	1212	1.01	—	—	—	—											
4080	1050	0.84	1082	0.89	1111	0.94	1140	0.99	1167	1.04	1195	1.09	—	—	—	—	—	—	—	—											
4490	1085	0.99	1117	1.04	1146	1.10	1175	1.15	1203	1.21	—	—	—	—	—	—	—	—	—	—											
4890	1122	1.15	1151	1.21	1181	1.27	—	—	—	—	—	—	—	—	—	—	—	—	—	—											

**Notes:**

1. For Standard Evaporator Fan Speed (RPM), reference [Table 97, p. 117](#).
2. Data includes pressure drop due to standard filters and wet coils.
3. Refer to [Table 107, p. 119](#) to determine additional static pressure drop due to other options/accessories.
4. 1.12 kW Fan Motor Heat (MBh) = 1.070 x Fan kW + 0.250
5. Factory supplied motors, in commercial equipment, are definite purpose motors, specifically designed and tested to operate reliably and continuously at all cataloged conditions. Using the full horsepower range of our fan motors as shown in our tabular data will not result in nuisance tripping or premature motor failure. Our product's warranty will not be affected.

(a) BAYLSDR005A  
(b) BAYHSDR013A



## Evaporator Fan Performance

**Table 22. Belt drive evaporator fan performance—6 tons—YSC072ED low gas heat—downflow airflow (IP)**

External Static Pressure (Inches of Water)																					
		.10		.20		.30		.40		.50		.60		.70		.80		.90		1.00	
cfm	rpm	bhp	rpm	bhp	rpm	bhp	rpm	bhp	rpm	bhp	rpm	bhp	rpm	bhp	rpm	bhp	rpm	bhp	rpm	bhp	
1.5-hp Std Motor & Field Supplied Low Static Drive <sup>(a)</sup>											1.5-hp Std Motor & Drive										
1920	—	—	596	0.29	653	0.35	706	0.41	753	0.46	797	0.52	839	0.57	877	0.63	914	0.68	948	0.73	
2160	587	0.33	643	0.39	695	0.45	745	0.51	791	0.57	834	0.64	873	0.70	912	0.76	949	0.83	983	0.89	
2400	639	0.43	691	0.50	740	0.57	785	0.63	830	0.70	872	0.77	911	0.84	948	0.91	983	0.99	1017	1.05	
2640	693	0.56	741	0.63	786	0.71	829	0.78	870	0.85	911	0.93	950	1.01	985	1.09	1021	1.17	1054	1.24	
2880	747	0.72	792	0.79	834	0.87	875	0.95	914	1.03	952	1.11	989	1.20	1024	1.28	1059	1.37	1092	1.45	
											1.5-hp Std Motor & Drive										

Continued

External Static Pressure (Inches of Water)																					
		1.10		1.20		1.30		1.40		1.50		1.60		1.70		1.80		1.90		2.00	
cfm	rpm	bhp	rpm	bhp	rpm	bhp	rpm	bhp	rpm	bhp	rpm	bhp	rpm	bhp	rpm	bhp	rpm	bhp	rpm	bhp	
1.5-hp Std Motor & Drive											1.5-hp Std Motor & Field Supplied High Static Drive <sup>(b)</sup>										
1920	980	0.79	1012	0.84	1042	0.89	1071	0.94	1100	1.00	1127	1.05	1153	1.10	1179	1.15	1205	1.20	—	—	
2160	1014	0.95	1046	1.01	1076	1.06	1104	1.12	1133	1.18	1160	1.24	1187	1.30	1212	1.36	—	—	—	—	
2400	1050	1.12	1082	1.19	1111	1.26	1140	1.33	1167	1.39	1195	1.46	—	—	—	—	—	—	—	—	
2640	1085	1.32	1117	1.40	1146	1.47	1175	1.55	1203	1.62	—	—	—	—	—	—	—	—	—	—	
2880	1122	1.54	1151	1.62	1181	1.71	—	—	—	—	—	—	—	—	—	—	—	—	—	—	

**Notes:**

1. For Standard Evaporator Fan Speed (RPM), reference [Table 97, p. 117](#).
2. Data includes pressure drop due to standard filters and wet coils.
3. Refer to [Table 108, p. 119](#) to determine additional static pressure drop due to other options/accessories.
4. 1.5-hp Fan Motor Heat (MBh) = 2.720 x Fan bhp + 0.850
5. Factory supplied motors, in commercial equipment, are definite purpose motors, specifically designed and tested to operate reliably and continuously at all cataloged conditions. Using the full horsepower range of our fan motors as shown in our tabular data will not result in nuisance tripping or premature motor failure. Our product's warranty will not be affected.

(a) BAYLSDR005A  
(b) BAYHSDR013A

## Evaporator Fan Performance

**Table 23. Belt drive evaporator fan performance—6 tons—YSC072ED—high gas heat—downflow airflow (SI)**

External Static Pressure (Pascals)																					
25		50		75		100		125		150		175		200		225		250			
m <sup>3</sup> /h	rpm	kW	rpm	kW	rpm	kW	rpm	kW	rpm	kW	rpm	kW	rpm	kW	rpm	kW	rpm	kW	rpm	kW	
1.12 Nom kW Std Motor & Field Supplied Low Static Drive <sup>(a)</sup>											1.12 Nom kW Std Motor & Drive										
3260	581	0.21	640	0.25	693	0.29	744	0.33	792	0.37	837	0.42	881	0.46	920	0.51	959	0.55	995	0.60	
3670	638	0.28	693	0.33	743	0.37	789	0.42	835	0.47	878	0.52	919	0.57	957	0.61	996	0.67	1032	0.72	
4080	698	0.37	748	0.43	794	0.48	838	0.53	879	0.58	920	0.63	960	0.69	998	0.74	1034	0.80	1069	0.85	
4490	758	0.49	803	0.54	847	0.60	889	0.66	928	0.71	966	0.77	1003	0.83	1039	0.89	1075	0.95	1107	1.01	
4890	818	0.62	861	0.68	902	0.74	941	0.81	978	0.87	1013	0.93	1048	0.99	1083	1.05	1116	1.12	1149	1.18	
											1.12 Nom kW Standard Motor & Drive										

Continued

External Static Pressure (Pascals)																					
275		300		325		350		375		400		425		450		475		500			
m <sup>3</sup> /h	rpm	kW	rpm	kW	rpm	kW	rpm	kW	rpm	kW	rpm	kW	rpm	kW	rpm	kW	rpm	kW	rpm	kW	
1.12 Nom kW Standard Motor & Drive																					
3260	1030	0.64	1063	0.69	1096	0.73	1127	0.78	1156	0.82	1186	0.86	1215	0.91	—	—	—	—	—	—	
3670	1066	0.77	1099	0.82	1131	0.87	1161	0.92	1191	0.97	—	—	—	—	—	—	—	—	—	—	
4080	1103	0.91	1135	0.96	1167	1.02	1196	1.08	—	—	—	—	—	—	—	—	—	—	—	—	
4490	1140	1.07	1172	1.13	1203	1.19	—	—	—	—	—	—	—	—	—	—	—	—	—	—	
4890	1181	1.25	—	—	—	—	—	—	—	—	—	—	—	—	—	—	—	—	—	—	
											1.12 Nom kW Standard Motor & Field Supplied High Static Drive <sup>(b)</sup>										

**Notes:**

1. For Standard Evaporator Fan Speed (RPM), reference [Table 97, p. 117](#).
2. Data includes pressure drop due to standard filters and wet coils.
3. Refer to [Table 107, p. 119](#) to determine additional static pressure drop due to other options/accessories.
4. 1.12 kW Fan Motor Heat (MBh) = 1.070 x Fan kW + 0.250
5. Factory supplied motors, in commercial equipment, are definite purpose motors, specifically designed and tested to operate reliably and continuously at all cataloged conditions. Using the full horsepower range of our fan motors as shown in our tabular data will not result in nuisance tripping or premature motor failure. Our product's warranty will not be affected.

(a) BAYLSDR005A  
(b) BAYHSDR013A



## Evaporator Fan Performance

**Table 24. Belt drive evaporator fan performance—6 tons—YSC072ED high gas heat—downflow airflow (IP)**

External Static Pressure (Inches of Water)																						
		.10		.20		.30		.40		.50		.60		.70		.80		.90		1.00		
cfm	rpm	bhp	rpm	bhp	rpm	bhp	rpm	bhp	rpm	bhp	rpm	bhp	rpm	bhp	rpm	bhp	rpm	bhp	rpm	bhp	rpm	bhp
1.5-hp Std Motor & Field Supplied Low Static Drive <sup>(a)</sup>											1.5-hp Std Motor & Drive											
1920	581	0.28	640	0.33	693	0.39	744	0.44	792	0.50	837	0.56	881	0.62	920	0.68	959	0.74	995	0.80		
2160	638	0.38	693	0.44	743	0.50	789	0.56	835	0.63	878	0.69	919	0.76	957	0.82	996	0.89	1032	0.96		
2400	698	0.50	748	0.57	794	0.64	838	0.71	879	0.78	920	0.85	960	0.92	998	0.99	1034	1.07	1069	1.14		
2640	758	0.65	803	0.73	847	0.80	889	0.88	928	0.95	966	1.03	1003	1.11	1039	1.19	1075	1.27	1107	1.35		
2880	818	0.83	861	0.91	902	0.99	941	1.08	978	1.16	1013	1.24	1048	1.32	1083	1.41	1116	1.50	1149	1.59		
											1.5-hp Std Motor Drive & Field Supplied High Static Drive <sup>(b)</sup>											

Continued

External Static Pressure (Inches of Water)																						
		1.10		1.20		1.30		1.40		1.50		1.60		1.70		1.80		1.90		2.00		
cfm	rpm	bhp	rpm	bhp	rpm	bhp	rpm	bhp	rpm	bhp	rpm	bhp	rpm	bhp	rpm	bhp	rpm	bhp	rpm	bhp	rpm	bhp
1.5-hp Std Motor & Drive						1.5-hp Std Motor & Field Supplied High Static Drive <sup>(c)</sup>																
1920	1030	0.86	1063	0.92	1096	0.98	1127	1.04	1156	1.10	1186	1.16	1215	1.22	—	—	—	—	—	—	—	—
2160	1066	1.03	1099	1.10	1131	1.17	1161	1.23	1191	1.30	—	—	—	—	—	—	—	—	—	—	—	—
2400	1103	1.22	1135	1.29	1167	1.37	1196	1.44	—	—	—	—	—	—	—	—	—	—	—	—	—	—
2640	1140	1.43	1172	1.51	1203	1.59	—	—	—	—	—	—	—	—	—	—	—	—	—	—	—	—
2880	1181	1.67	—	—	—	—	—	—	—	—	—	—	—	—	—	—	—	—	—	—	—	—

**Notes:**

1. For Standard Evaporator Fan Speed (RPM), reference [Table 97, p. 117](#).
2. Data includes pressure drop due to standard filters and wet coils.
3. Refer to [Table 108, p. 119](#) to determine additional static pressure drop due to other options/accessories.
4. 1.5-hp Fan Motor Heat (MBh) = 2.720 x Fan bhp + 0.850
5. Factory supplied motors, in commercial equipment, are definite purpose motors, specifically designed and tested to operate reliably and continuously at all cataloged conditions. Using the full horsepower range of our fan motors as shown in our tabular data will not result in nuisance tripping or premature motor failure. Our product's warranty will not be affected.

(a) BAYLSDR005A  
 (b) BAYHSDR013A  
 (c) BAYHSDR013A



## Evaporator Fan Performance

**Table 25. Belt drive evaporator fan performance - 6 tons - YSC072ED - low gas heat - horizontal airflow (SI)**

External Static Pressure (Pascals)																					
		25		50		75		100		125		150		175		200		225		250	
m <sup>3</sup> /h	rpm	kW	rpm	kW	rpm	kW	rpm	kW	rpm	kW	rpm	kW	rpm	kW	rpm	kW	rpm	kW	rpm	kW	
1.12 Nom kW Std Motor & Field Supplied Low Static Drive <sup>(a)</sup>											1.12 Nom kW Std Motor & Drive										
3260	604	0.22	661	0.26	714	0.31	763	0.35	809	0.39	852	0.44	892	0.48	929	0.52	964	0.56	997	0.60	
3670	664	0.30	718	0.35	766	0.40	812	0.45	856	0.50	896	0.54	936	0.59	974	0.64	1009	0.69	1041	0.74	
4080	726	0.40	776	0.46	821	0.51	864	0.56	906	0.62	944	0.67	981	0.72	1017	0.78	1052	0.83	1085	0.89	
4490	788	0.53	835	0.59	878	0.64	917	0.70	957	0.76	994	0.82	1029	0.88	1063	0.94	1096	1.00	1129	1.06	
4890	852	0.67	895	0.74	936	0.80	973	0.86	1009	0.93	1045	0.99	1080	1.06	1112	1.12	1144	1.18	1175	1.25	
											1.12 Nom kW Standard Motor & Drive										

Continued

External Static Pressure (Pascals)																					
		275		300		325		350		375		400		425		450		475		500	
m <sup>3</sup> /h	rpm	kW	rpm	kW	rpm	kW	rpm	kW	rpm	kW	rpm	kW	rpm	kW	rpm	kW	rpm	kW	rpm	kW	
1.12 Nom kW Standard Motor Drive											1.12 Nom kW Standard Motor & Field Supplied High Static Drive <sup>(b)</sup>										
3260	1030	0.64	1060	0.68	1090	0.72	1118	0.76	1146	0.80	1173	0.84	1199	0.88	—	—	—	—	—	—	
3670	1073	0.78	1104	0.83	1132	0.87	1161	0.92	1188	0.97	1214	1.01	—	—	—	—	—	—	—	—	
4080	1117	0.94	1147	0.99	1176	1.04	1203	1.09	—	—	—	—	—	—	—	—	—	—	—	—	
4490	1161	1.12	1191	1.17	1220	1.23	—	—	—	—	—	—	—	—	—	—	—	—	—	—	
4890	1205	1.31	—	—	—	—	—	—	—	—	—	—	—	—	—	—	—	—	—	—	

**Notes:**

1. For Standard Evaporator Fan Speed (RPM), reference [Table 97, p. 117](#).
2. Data includes pressure drop due to standard filters and wet coils.
3. Refer to [Table 107, p. 119](#) to determine additional static pressure drop due to other options/accessories.
4. 1.12 kW Fan Motor Heat (MBh) = 1.070 x Fan kW + 0.250
5. Factory supplied motors, in commercial equipment, are definite purpose motors, specifically designed and tested to operate reliably and continuously at all cataloged conditions. Using the full horsepower range of our fan motors as shown in our tabular data will not result in nuisance tripping or premature motor failure. Our product's warranty will not be affected.

(a) BAYLSDR005A  
 (b) BAYHSDR013A



## Evaporator Fan Performance

**Table 26. Belt drive evaporator fan performance—6 tons—YSC072ED low gas heat—horizontal airflow (IP)**

External Static Pressure (Inches of Water)																					
		.10		.20		.30		.40		.50		.60		.70		.80		.90		1.00	
cfm	rpm	bhp	rpm	bhp	rpm	bhp	rpm	bhp	rpm	bhp	rpm	bhp	rpm	bhp	rpm	bhp	rpm	bhp	rpm	bhp	
1.5-hp Std Motor & Field Supplied Low Static Drive <sup>(a)</sup>											1.5-hp Std Motor & Drive										
1920	604	0.30	661	0.36	714	0.41	763	0.47	809	0.53	852	0.59	892	0.64	929	0.70	964	0.75	997	0.81	
2160	664	0.41	718	0.47	766	0.54	812	0.60	856	0.67	896	0.73	936	0.79	974	0.86	1009	0.92	1041	0.99	
2400	726	0.54	776	0.61	821	0.68	864	0.76	906	0.83	944	0.90	981	0.97	1017	1.04	1052	1.12	1085	1.19	
2640	788	0.70	835	0.79	878	0.86	917	0.94	957	1.02	994	1.10	1029	1.18	1063	1.26	1096	1.33	1129	1.41	
2880	852	0.90	895	0.99	936	1.07	973	1.16	1009	1.24	1045	1.33	1080	1.42	1112	1.50	1144	1.59	1175	1.67	
											1.5-hp Std Motor Drive & Field Supplied High Static Drive <sup>(b)</sup>										

Continued

External Static Pressure (Inches of Water)																					
		1.10		1.20		1.30		1.40		1.50		1.60		1.70		1.80		1.90		2.00	
cfm	rpm	bhp	rpm	bhp	rpm	bhp	rpm	bhp	rpm	bhp	rpm	bhp	rpm	bhp	rpm	bhp	rpm	bhp	rpm	bhp	
1.5-hp Std Motor & Drive						1.5-hp Std Motor & Field Supplied High Static Drive <sup>(c)</sup>															
1920	1030	0.86	1060	0.92	1090	0.97	1118	1.02	1146	1.08	1173	1.13	1199	1.18	—	—	—	—	—	—	
2160	1073	1.05	1104	1.11	1132	1.17	1161	1.23	1188	1.30	1214	1.35	—	—	—	—	—	—	—	—	
2400	1117	1.26	1147	1.33	1176	1.40	1203	1.47	—	—	—	—	—	—	—	—	—	—	—	—	
2640	1161	1.49	1191	1.57	1220	1.65	—	—	—	—	—	—	—	—	—	—	—	—	—	—	
2880	1205	1.76	—	—	—	—	—	—	—	—	—	—	—	—	—	—	—	—	—	—	

**Notes:**

1. For Standard Evaporator Fan Speed (RPM), reference [Table 97, p. 117](#).
2. Data includes pressure drop due to standard filters and wet coils.
3. Refer to [Table 108, p. 119](#) to determine additional static pressure drop due to other options/accessories.
4. 1.5-hp Fan Motor Heat (MBh) = 2.720 x Fan bhp + 0.850
5. Factory supplied motors, in commercial equipment, are definite purpose motors, specifically designed and tested to operate reliably and continuously at all cataloged conditions. Using the full horsepower range of our fan motors as shown in our tabular data will not result in nuisance tripping or premature motor failure. Our product's warranty will not be affected.

(a) BAYLSDR005A  
 (b) BAYHSDR013A  
 (c) BAYHSDR013A

## Evaporator Fan Performance

**Table 27. Belt drive evaporator fan performance—6 tons—YSC072ED—high gas heat—horizontal airflow (SI)**

																						External Static Pressure (Pascals)									
		25		50		75		100		125		150		175		200		225		250											
m <sup>3</sup> /h	rpm	kW	rpm	kW	rpm	kW	rpm	kW	rpm	kW	rpm	kW	rpm	kW	rpm	kW	rpm	kW	rpm	kW											
<b>2-hp Std Motor &amp; Field Supplied Low Static Drive<sup>(a)</sup></b>										<b>2-hp Std Motor &amp; Drive</b>																					
3260	644	0.25	700	0.29	751	0.33	797	0.37	840	0.41	880	0.45	920	0.50	957	0.54	993	0.59	1026	0.63											
3670	710	0.34	762	0.39	810	0.43	853	0.48	894	0.53	932	0.57	969	0.62	1005	0.67	1040	0.72	1073	0.77											
4080	777	0.45	825	0.50	870	0.56	911	0.61	950	0.66	987	0.71	1022	0.76	1056	0.82	1088	0.87	1121	0.92											
4490	845	0.58	890	0.65	932	0.71	971	0.76	1008	0.82	1043	0.88	1077	0.93	1109	0.99	1141	1.05	1171	1.10											
4890	914	0.75	956	0.81	995	0.88	1032	0.94	1068	1.01	1102	1.07	1133	1.13	1164	1.19	1195	1.25	1224	1.32											
										<b>2-hp Standard Motor &amp; Field Supplied High Static Drive<sup>(b)</sup></b>																					

**Continued**

																						External Static Pressure (Pascals)									
		275		300		325		350		375		400		425		450		475		500											
m <sup>3</sup> /h	rpm	kW	rpm	kW	rpm	kW	rpm	kW	rpm	kW	rpm	kW	rpm	kW	rpm	kW	rpm	kW	rpm	kW											
<b>2-hp Standard Motor Drive</b>										<b>2-hp Standard Motor &amp; Field Supplied High Static Drive<sup>(c)</sup></b>																					
3260	1059	0.67	1090	0.72	1121	0.76	1149	0.80	1178	0.84	1205	0.89	—	—	—	—	—	—	—	—											
3670	1105	0.82	1135	0.86	1165	0.91	1194	0.96	—	—	—	—	—	—	—	—	—	—	—	—											
4080	1152	0.98	1182	1.03	1212	1.09	—	—	—	—	—	—	—	—	—	—	—	—	—	—											
4490	1200	1.16	—	—	—	—	—	—	—	—	—	—	—	—	—	—	—	—	—	—											
4890	—	—	—	—	—	—	—	—	—	—	—	—	—	—	—	—	—	—	—	—											

**Notes:**

1. For Standard Evaporator Fan Speed (RPM), reference [Table 97, p. 117](#).
2. Data includes pressure drop due to standard filters and wet coils.
3. Refer to [Table 107, p. 119](#) to determine additional static pressure drop due to other options/accessories.
4. 1.12 kW Fan Motor Heat (MBh) = 1.070 x Fan kW + 0.250
5. Factory supplied motors, in commercial equipment, are definite purpose motors, specifically designed and tested to operate reliably and continuously at all cataloged conditions. Using the full horsepower range of our fan motors as shown in our tabular data will not result in nuisance tripping or premature motor failure. Our product's warranty will not be affected.

(a) BAYLSDR005A  
 (b) BAYHSDR013A  
 (c) BAYHSDR013A



## Evaporator Fan Performance

**Table 28. Belt drive evaporator fan performance—6 tons—YSC072ED high gas heat—horizontal airflow (IP)**

cfm	External Static Pressure (Inches of Water)																			
	.10		.20		.30		.40		.50		.60		.70		.80		.90		1.00	
	rpm	bhp	rpm	bhp	rpm	bhp	rpm	bhp	rpm	bhp	rpm	bhp	rpm	bhp	rpm	bhp	rpm	bhp	rpm	bhp
2-hp Std Motor & Field Supplied Low Static Drive <sup>(a)</sup>										2-hp Std Motor & Drive										
1920	644	0.33	700	0.39	751	0.44	797	0.50	840	0.55	880	0.61	920	0.67	957	0.73	993	0.79	1026	0.84
2160	710	0.45	762	0.52	810	0.58	853	0.64	894	0.70	932	0.77	969	0.83	1005	0.89	1040	0.96	1073	1.03
2400	777	0.60	825	0.68	870	0.75	911	0.82	950	0.89	987	0.96	1022	1.02	1056	1.09	1088	1.16	1121	1.24
2640	845	0.78	890	0.86	932	0.95	971	1.02	1008	1.10	1043	1.17	1077	1.25	1109	1.33	1141	1.40	1171	1.48
2880	914	1.00	956	1.09	995	1.18	1032	1.26	1068	1.35	1102	1.43	1133	1.51	1164	1.60	1195	1.68	1224	1.76
										2-hp Std Motor Drive & Field Supplied High Static Drive <sup>(b)</sup>										

Continued

cfm	External Static Pressure (Inches of Water)																			
	1.10		1.20		1.30		1.40		1.50		1.60		1.70		1.80		1.90		2.00	
	rpm	bhp	rpm	bhp	rpm	bhp	rpm	bhp	rpm	bhp	rpm	bhp	rpm	bhp	rpm	bhp	rpm	bhp	rpm	bhp
2-hp Std Motor & Drive					2-hp Std Motor & Field Supplied High Static Drive <sup>(c)</sup>															
1920	1059	0.90	1090	0.96	1121	1.02	1149	1.07	1178	1.13	1205	1.19	—	—	—	—	—	—	—	—
2160	1105	1.09	1135	1.16	1165	1.22	1194	1.29	—	—	—	—	—	—	—	—	—	—	—	—
2400	1152	1.31	1182	1.38	1212	1.46	—	—	—	—	—	—	—	—	—	—	—	—	—	—
2640	1200	1.56	—	—	—	—	—	—	—	—	—	—	—	—	—	—	—	—	—	—
2880	—	—	—	—	—	—	—	—	—	—	—	—	—	—	—	—	—	—	—	—

**Notes:**

1. For Standard Evaporator Fan Speed (RPM), reference [Table 97, p. 117](#).
2. Data includes pressure drop due to standard filters and wet coils.
3. Refer to [Table 108, p. 119](#) to determine additional static pressure drop due to other options/accessories.
4. 1.5-hp Fan Motor Heat (MBh) = 2.720 x Fan bhp + 0.850
5. Factory supplied motors, in commercial equipment, are definite purpose motors, specifically designed and tested to operate reliably and continuously at all cataloged conditions. Using the full horsepower range of our fan motors as shown in our tabular data will not result in nuisance tripping or premature motor failure. Our product's warranty will not be affected.

(a) BAYLSDR005A  
 (b) BAYHSDR013A  
 (c) BAYHSDR013A

## Evaporator Fan Performance

**Table 29. Belt drive evaporator fan performance—6 tons—WSC072ED—downflow airflow (SI)**

External Static Pressure (Pascals)																				
25		50		75		100		125		150		175		200		225		250		
m <sup>3</sup> /h	rpm	kW	rpm	kW	rpm	kW	rpm	kW	rpm	kW	rpm	kW	rpm	kW	rpm	kW	rpm	kW	rpm	kW
1.12 Nom kW Std Motor & Field Supplied Low Static Drive <sup>(a)</sup>														1.12 Nom kW Std Motor & Drive						
3260	—	—	560	0.20	616	0.23	669	0.27	719	0.31	763	0.35	806	0.39	844	0.43	882	0.47	918	0.51
3670	—	—	601	0.26	654	0.30	703	0.34	750	0.39	794	0.43	836	0.48	874	0.52	911	0.56	946	0.61
4080	591	0.28	645	0.33	694	0.38	740	0.42	784	0.47	826	0.52	867	0.57	905	0.62	941	0.67	976	0.72
4490	638	0.37	690	0.42	735	0.47	779	0.52	820	0.57	861	0.63	898	0.68	937	0.73	972	0.79	1007	0.84
4890	687	0.46	735	0.52	779	0.58	820	0.63	859	0.69	897	0.75	933	0.80	969	0.86	1004	0.92	1038	0.98

Continued

External Static Pressure (Pascals)																				
275		300		325		350		375		400		425		450		475		500		
m <sup>3</sup> /h	rpm	kW	rpm	kW	rpm	kW	rpm	kW	rpm	kW	rpm	kW	rpm	kW	rpm	kW	rpm	kW	rpm	kW
1.12 Nom kW Std Motor & Drive										1.12 Nom kW Standard Motor & Field Supplied High Static Drive <sup>(b)</sup>										
1920	953	0.55	985	0.59	1017	0.63	1048	0.67	1076	0.71	1104	0.74	1133	0.78	1159	0.82	1186	0.86	1211	0.90
2160	980	0.65	1012	0.70	1044	0.74	1074	0.79	1103	0.83	1132	0.87	1159	0.92	1186	0.96	1211	1.00	—	—
2400	1009	0.77	1041	0.82	1071	0.86	1101	0.91	1131	0.97	1157	1.01	1185	1.06	1212	1.11	—	—	—	—
2640	1039	0.90	1071	0.95	1100	1.00	1130	1.06	1159	1.11	1186	1.17	1213	1.22	—	—	—	—	—	—
2880	1069	1.04	1101	1.10	1131	1.16	1160	1.22	1187	1.28	1215	1.34	—	—	—	—	—	—	—	—

**Notes:**

1. For Standard Evaporator Fan Speed (RPM), reference [Table 101, p. 117](#).
2. Data includes pressure drop due to standard filters and wet coils.
3. Refer to [Table 109, p. 120](#) to determine additional static pressure drop due to other options/accessories.
4. 1.12 kW Fan Motor Heat (MBh) = 1.070 x Fan kW + 0.250
5. Factory supplied motors, in commercial equipment, are definite purpose motors, specifically designed and tested to operate reliably and continuously at all cataloged conditions. Using the full horsepower range of our fan motors as shown in our tabular data will not result in nuisance tripping or premature motor failure. Our product's warranty will not be affected.

(a) BAYLSDR005A  
 (b) BAYHSDR013A



## Evaporator Fan Performance

**Table 30. Belt drive evaporator fan performance—6 tons—WSC072ED—downflow airflow (IP)**

External Static Pressure (Inches of Water)																					
		.10		.20		.30		.40		.50		.60		.70		.80		.90		1.00	
cfm	rpm	bhp	rpm	bhp	rpm	bhp	rpm	bhp	rpm	bhp	rpm	bhp	rpm	bhp	rpm	bhp	rpm	bhp	rpm	bhp	
1.5-hp Std Motor & Field Supplied Low Static Drive <sup>(a)</sup>											1.15-hp Std Motor & Drive										
1920	—	—	560	0.26	616	0.31	669	0.37	719	0.42	763	0.47	806	0.52	844	0.58	882	0.63	918	0.68	
2160	—	—	601	0.34	654	0.40	703	0.46	750	0.52	794	0.58	836	0.64	874	0.70	911	0.76	946	0.81	
2400	591	0.38	645	0.44	694	0.50	740	0.57	784	0.63	826	0.70	867	0.76	905	0.83	941	0.90	976	0.96	
2640	638	0.49	690	0.56	735	0.63	779	0.70	820	0.77	861	0.84	898	0.91	937	0.98	972	1.06	1007	1.13	
2880	687	0.62	735	0.70	779	0.77	820	0.85	859	0.92	897	1.00	933	1.08	969	1.16	1004	1.23	1038	1.31	

Continued

External Static Pressure (Inches of Water)																					
		1.10		1.20		1.30		1.40		1.50		1.60		1.70		1.80		1.90		2.00	
cfm	rpm	bhp	rpm	bhp	rpm	bhp	rpm	bhp	rpm	bhp	rpm	bhp	rpm	bhp	rpm	bhp	rpm	bhp	rpm	bhp	
1.5-hp Std Motor & Drive											1.5-hp Std Motor & Field Supplied High Static Drive <sup>(b)</sup>										
1920	953	0.74	985	0.79	1017	0.84	1048	0.89	1076	0.95	1104	1.00	1133	1.05	1159	1.10	1186	1.15	1211	1.20	
2160	980	0.87	1012	0.93	1044	0.99	1074	1.05	1103	1.11	1132	1.17	1159	1.23	1186	1.29	1211	1.35	—	—	
2400	1009	1.03	1041	1.09	1071	1.16	1101	1.22	1131	1.29	1157	1.36	1185	1.43	1212	1.49	—	—	—	—	
2640	1039	1.20	1071	1.27	1100	1.35	1130	1.42	1159	1.49	1186	1.56	1213	1.64	—	—	—	—	—	—	
2880	1069	1.39	1101	1.48	1131	1.55	1160	1.63	1187	1.71	1215	1.79	—	—	—	—	—	—	—	—	

**Notes:**

1. For Standard Evaporator Fan Speed (RPM), reference [Table 101, p. 117](#).
2. Data includes pressure drop due to standard filters and wet coils.
3. Refer to [Table 110, p. 120](#) to determine additional static pressure drop due to other options/accessories.
4. 1.5-hp Fan Motor Heat (MBh) = 2.720 x Fan bhp + 0.850
5. Factory supplied motors, in commercial equipment, are definite purpose motors, specifically designed and tested to operate reliably and continuously at all cataloged conditions. Using the full horsepower range of our fan motors as shown in our tabular data will not result in nuisance tripping or premature motor failure. Our product's warranty will not be affected.

(a) BAYLSDR005A  
(b) BAYHSDR013A

## Evaporator Fan Performance

**Table 31. Belt drive evaporator fan performance—6 tons—WSC072ED—horizontal airflow (SI)**

External Static Pressure (Pascals)																					
25		50		75		100		125		150		175		200		225		250			
m <sup>3</sup> /h	rpm	kW	rpm	kW	rpm	kW	rpm	kW	rpm	kW	rpm	kW	rpm	kW	rpm	kW	rpm	kW	rpm	kW	
<b>1.12 Nom kW Std Motor &amp; Field Supplied Low Static Drive<sup>(a)</sup></b>											<b>1.12 Nom kW Std Motor &amp; Drive</b>										
3260	559	0.19	618	0.23	675	0.27	730	0.32	786	0.36	841	0.42	889	0.47	935	0.52	978	0.57	1018	0.62	
3670	615	0.26	667	0.30	719	0.35	770	0.40	818	0.44	868	0.50	917	0.56	963	0.62	1006	0.68	1047	0.73	
4080	671	0.35	720	0.40	766	0.45	813	0.50	858	0.55	901	0.60	945	0.66	991	0.73	1033	0.79	1076	0.86	
4490	728	0.45	774	0.51	815	0.56	859	0.61	901	0.67	941	0.72	981	0.78	1021	0.85	1062	0.92	1103	0.99	
4890	786	0.58	829	0.63	868	0.69	906	0.75	946	0.81	985	0.87	1022	0.93	1058	1.00	1095	1.06	1133	1.14	
											<b>1.12 Nom kW Std Motor &amp; Field Supplied High Static Drive<sup>(b)</sup></b>										

Continued

External Static Pressure (Pascals)																					
275		300		325		350		375		400		425		450		475		500			
m <sup>3</sup> /h	rpm	kW	rpm	kW	rpm	kW	rpm	kW	rpm	kW	rpm	kW	rpm	kW	rpm	kW	rpm	kW	rpm	kW	
<b>1.12 Nom kW Std Motor &amp; Drive</b>																					
3260	1058	0.67	1096	0.72	1130	0.77	1165	0.82	1198	0.87	—	—	—	—	—	—	—	—	—	—	
3670	1086	0.79	1123	0.85	1157	0.90	1193	0.96	—	—	—	—	—	—	—	—	—	—	—	—	
4080	1114	0.92	1150	0.99	1187	1.05	1221	1.12	—	—	—	—	—	—	—	—	—	—	—	—	
4490	1142	1.06	1179	1.13	1214	1.21	—	—	—	—	—	—	—	—	—	—	—	—	—	—	
4890	1169	1.21	1207	1.29	—	—	—	—	—	—	—	—	—	—	—	—	—	—	—	—	
											<b>1.12 Nom kW Standard Motor &amp; Field Supplied High Static Drive<sup>(c)</sup></b>										

**Notes:**

1. For Standard Evaporator Fan Speed (RPM), reference [Table 101, p. 117](#).
2. Data includes pressure drop due to standard filters and wet coils.
3. Refer to [Table 109, p. 120](#) to determine additional static pressure drop due to other options/accessories.
4. 1.12 kW Fan Motor Heat (MBh) = 1.070 x Fan kW + 0.250
5. Factory supplied motors, in commercial equipment, are definite purpose motors, specifically designed and tested to operate reliably and continuously at all cataloged conditions. Using the full horsepower range of our fan motors as shown in our tabular data will not result in nuisance tripping or premature motor failure. Our product's warranty will not be affected.

(a) BAYLSDR005A  
 (b) BAYHSDR013A  
 (c) BAYHSDR013A



## Evaporator Fan Performance

**Table 32. Belt drive evaporator fan performance—6 tons—WSC072ED—horizontal airflow (IP)**

External Static Pressure (Inches of Water)																					
		.10		.20		.30		.40		.50		.60		.70		.80		.90		1.00	
cfm	rpm	bhp	rpm	bhp	rpm	bhp	rpm	bhp	rpm	bhp	rpm	bhp	rpm	bhp	rpm	bhp	rpm	bhp	rpm	bhp	
<b>1.5-hp Std Motor &amp; Field Supplied Low Static Drive<sup>(a)</sup></b>											<b>1.15-hp Std Motor &amp; Drive</b>										
1920	559	0.26	618	0.31	675	0.36	730	0.42	786	0.49	841	0.56	889	0.63	935	0.70	978	0.77	1018	0.83	
2160	615	0.35	667	0.41	719	0.47	770	0.53	818	0.60	868	0.67	917	0.75	963	0.83	1006	0.91	1047	0.98	
2400	671	0.47	720	0.53	766	0.60	813	0.66	858	0.73	901	0.81	945	0.88	991	0.97	1033	1.06	1076	1.15	
2640	728	0.61	774	0.68	815	0.75	859	0.82	901	0.90	941	0.97	981	1.05	1021	1.14	1062	1.23	1103	1.33	
2880	786	0.77	829	0.85	868	0.93	906	1.00	946	1.09	985	1.17	1022	1.25	1058	1.33	1095	1.43	1133	1.52	
											<b>1.5-hp Std Motor &amp; Field Supplied High Static Drive<sup>(b)</sup></b>										

Continued

External Static Pressure (Inches of Water)																					
		1.10		1.20		1.30		1.40		1.50		1.60		1.70		1.80		1.90		2.00	
cfm	rpm	bhp	rpm	bhp	rpm	bhp	rpm	bhp	rpm	bhp	rpm	bhp	rpm	bhp	rpm	bhp	rpm	bhp	rpm	bhp	
<b>1.5-hp Std Motor &amp; Drive</b>																					
1920	1058	0.90	1096	0.97	1130	1.03	1165	1.10	1198	1.17	—	—	—	—	—	—	—	—	—	—	
2160	1086	1.06	1123	1.14	1157	1.21	1193	1.29	—	—	—	—	—	—	—	—	—	—	—	—	
2400	1114	1.24	1150	1.32	1187	1.41	1221	1.49	—	—	—	—	—	—	—	—	—	—	—	—	
2640	1142	1.43	1179	1.52	1214	1.62	—	—	—	—	—	—	—	—	—	—	—	—	—	—	
2880	1169	1.63	1207	1.73	—	—	—	—	—	—	—	—	—	—	—	—	—	—	—	—	
<b>1.5-hp Std Motor &amp; Field Supplied High Static Drive</b>																					

**Notes:**

1. For Standard Evaporator Fan Speed (RPM), reference [Table 101, p. 117](#).
2. Data includes pressure drop due to standard filters and wet coils.
3. Refer to [Table 110, p. 120](#) to determine additional static pressure drop due to other options/accessories.
4. 1.5-hp Fan Motor Heat (MBh) = 2.720 x Fan bhp + 0.850
5. Factory supplied motors, in commercial equipment, are definite purpose motors, specifically designed and tested to operate reliably and continuously at all cataloged conditions. Using the full horsepower range of our fan motors as shown in our tabular data will not result in nuisance tripping or premature motor failure. Our product's warranty will not be affected.

(a) BAYLSDR005A  
(b) BAYHSDR013A



## Evaporator Fan Performance

**Table 33. Belt drive evaporator fan performance—7½ tons—TSC090ED—downflow airflow (SI)**

External Static Pressure (Pascals)																				
25		50		75		100		125		150		175		200		225		250		
m <sup>3</sup> /h	rpm	kW	rpm	kW	rpm	kW	rpm	kW	rpm	kW	rpm	kW	rpm	kW	rpm	kW	rpm	kW	rpm	kW
1.12 Nom kW Std Motor & Field Supplied Low Static Drive <sup>(a)</sup>														1.12 Nom kW Std Motor & Drive						
4080	—	—	—	—	703	0.40	749	0.45	793	0.50	835	0.55	876	0.60	914	0.66	950	0.72	985	0.77
4590	—	—	706	0.45	754	0.52	799	0.58	839	0.63	880	0.69	918	0.75	954	0.81	991	0.87	1024	0.93
5100	709	0.51	761	0.59	808	0.66	851	0.73	890	0.79	927	0.86	963	0.92	997	0.99	1031	1.05	1064	1.11
5610	770	0.67	819	0.75	863	0.83	904	0.91	942	0.98	977	1.05	1011	1.12	1043	1.19	1076	1.27	1107	1.34
6120	831	0.85	877	0.94	919	1.03	958	1.11	995	1.20	1029	1.28	1062	1.36	1093	1.43	1123	1.51	1153	1.59

Continued

External Static Pressure (Pascals)																				
275		300		325		350		375		400		425		450		475		500		
m <sup>3</sup> /h	rpm	kW	rpm	kW	rpm	kW	rpm	kW	rpm	kW	rpm	kW	rpm	kW	rpm	kW	rpm	kW	rpm	kW
1.12 Nom kW Std Motor & Drive												2.24 Nom kW Oversized Motor & Drive <sup>(b)</sup>								
4080	1019	0.83	1051	0.89	1083	0.95	1113	1.00	1142	1.06	1171	1.12	1200	1.18	1228	1.24	1254	1.29	1281	1.36
4590	1057	1.00	1088	1.06	1118	1.12	1148	1.18	1178	1.25	1205	1.31	1234	1.38	1260	1.45	1287	1.51	1312	1.58
5100	1097	1.18	1128	1.25	1158	1.33	1186	1.40	1214	1.47	1241	1.53	1269	1.61	1295	1.68	1320	1.75	1346	1.82
5610	1137	1.41	1168	1.48	1197	1.55	1227	1.63	1254	1.71	1281	1.78	1306	1.86	1332	1.94	1357	2.02	1381	2.09
6120	1182	1.66	1211	1.74	1239	1.82	1266	1.90	1293	1.97	1321	2.06	1346	2.14	1371	2.22	1396	2.31	1419	2.40
1.50 Nom kW Std Motor & Field Supplied High Static Drive or 2.24 Nom kW Oversized Motor & Drive <sup>(c)</sup>																				

**Notes:**

1. For Standard Evaporator Fan Speed (RPM), reference [Table 97, p. 117](#).
2. Data includes pressure drop due to standard filters and wet coils.
3. Refer to [Table 107, p. 119](#) to determine additional static pressure drop due to other options/accessories.
4. 1.50 kW Fan Motor Heat (kW) = 1.20 x Fan kW + .06. 2.24 kW Fan Motor Heat (kW) = 1.140 x kW - .110.
5. Factory supplied motors, in commercial equipment, are definite purpose motors, specifically designed and tested to operate reliably and continuously at all cataloged conditions. Using the full horsepower range of our fan motors as shown in our tabular data will not result in nuisance tripping or premature motor failure. Our product's warranty will not be affected.

(a) BAYLSDR005A

(b) BAYHSMT097A

(c) BAYHSDR013A (or 2.24 Nom kW Oversized Motor and Drive)



## Evaporator Fan Performance

**Table 34. Belt drive evaporator fan performance—7½ tons—TSC090ED—downflow airflow (IP)**

External Static Pressure (Inches of Water)																					
		.10		.20		.30		.40		.50		.60		.70		.80		.90		1.00	
cfm	rpm	bhp	rpm	bhp	rpm	bhp	rpm	bhp	rpm	bhp	rpm	bhp	rpm	bhp	rpm	bhp	rpm	bhp	rpm	bhp	
2-hp Std Motor & Field Supplied Low Static Drive <sup>(a)</sup>											2-hp Std Motor & Drive										
2400	—	—	—	—	703	0.53	749	0.60	793	0.67	835	0.74	876	0.81	914	0.88	950	0.96	985	1.04	
2700	—	—	706	0.61	754	0.69	799	0.77	839	0.85	880	0.93	918	1.01	954	1.08	991	1.16	1024	1.25	
3000	709	0.69	761	0.79	808	0.89	851	0.98	890	1.07	927	1.15	963	1.24	997	1.32	1031	1.41	1064	1.49	
3300	770	0.89	819	1.01	863	1.11	904	1.22	942	1.32	977	1.41	1011	1.51	1043	1.60	1076	1.70	1107	1.79	
3600	831	1.14	877	1.26	919	1.38	958	1.49	995	1.61	1029	1.71	1062	1.82	1093	1.92	1123	2.02	1153	2.13	

Continued

External Static Pressure (Inches of Water)																					
		1.10		1.20		1.30		1.40		1.50		1.60		1.70		1.80		1.90		2.00	
cfm	rpm	bhp	rpm	bhp	rpm	bhp	rpm	bhp	rpm	bhp	rpm	bhp	rpm	bhp	rpm	bhp	rpm	bhp	rpm	bhp	
2-hp Std Motor & Drive											3-hp Oversized Motor & Drive <sup>(b)</sup>										
2400	1019	1.11	1051	1.19	1083	1.27	1113	1.35	1142	1.42	1171	1.50	1200	1.58	1228	1.66	1254	1.73	1281	1.82	
2700	1057	1.34	1088	1.42	1118	1.50	1148	1.59	1178	1.68	1205	1.76	1234	1.86	1260	1.94	1287	2.03	1312	2.11	
3000	1097	1.59	1128	1.68	1158	1.78	1186	1.87	1214	1.97	1241	2.06	1269	2.15	1295	2.25	1320	2.34	1346	2.44	
3300	1137	1.88	1168	1.98	1197	2.08	1227	2.18	1254	2.29	1281	2.39	1306	2.50	1332	2.60	1357	2.70	1381	2.80	
3600	1182	2.23	1211	2.34	1239	2.44	1266	2.54	1293	2.65	1321	2.76	1346	2.87	1371	2.98	1396	3.10	1419	3.21	
2-hp Std Motor & Field Supplied High Static Drive or 3-hp Oversized Motor & Drive <sup>(c)</sup>																					

**Notes:**

1. For Standard Evaporator Fan Speed (RPM), reference [Table 97, p. 117](#).
2. Data includes pressure drop due to standard filters and wet coils.
3. Refer to [Table 108, p. 119](#) to determine additional static pressure drop due to other options/accessories.
4. 2-hp Fan Motor Heat (MBh) = 3.100 x Fan bhp + .200. 3-hp Fan Motor Heat (MBh) = 2.900 x Fan bhp - .3800.
5. Factory supplied motors, in commercial equipment, are definite purpose motors, specifically designed and tested to operate reliably and continuously at all cataloged conditions. Using the full horsepower range of our fan motors as shown in our tabular data will not result in nuisance tripping or premature motor failure. Our product's warranty will not be affected.

(a) BAYLSDR005A  
 (b) BAYHSMT097A  
 (c) BAYHSDR013A (or 3-hp Oversized Motor and Drive)

## Evaporator Fan Performance

**Table 35. Belt drive evaporator fan performance—7½ tons—TSC090ED—horizontal airflow (SI)**

																						External Static Pressure (Pascals)									
		25		50		75		100		125		150		175		200		225		250											
m <sup>3</sup> /h	rpm	kW	rpm	kW	rpm	kW	rpm	kW	rpm	kW	rpm	kW	rpm	kW	rpm	kW	rpm	kW	rpm	kW											
<b>1.50 Nom kW Std Motor &amp; Field Supplied Low Static Drive<sup>(a)</sup></b>											<b>1.50 Nom kW Std Motor &amp; Drive</b>																				
4080	—	—	706	0.40	753	0.46	799	0.51	842	0.57	883	0.63	924	0.69	965	0.76	1005	0.82	1047	0.89											
4590	720	0.47	770	0.54	814	0.60	856	0.66	896	0.73	935	0.79	972	0.86	1007	0.92	1044	0.99	1080	1.07											
5100	789	0.63	835	0.71	877	0.78	917	0.85	953	0.91	989	0.98	1025	1.06	1059	1.13	1091	1.20	1123	1.27											
5610	858	0.82	901	0.91	941	0.99	978	1.07	1014	1.14	1047	1.21	1080	1.29	1112	1.37	1144	1.45	1175	1.53											
6120	928	1.05	969	1.14	1006	1.23	1042	1.32	1076	1.40	1107	1.49	1138	1.57	1168	1.65	1198	1.73	1227	1.82											
<b>1.50 Nom kW Std Motor &amp; Field Supplied High Static Drive or 2.24 Nom kW Oversized Motor &amp; Drive<sup>(b)</sup></b>											<b>2.24 Nom kW Oversized Motor &amp; Drive<sup>(c)</sup></b>																				

Continued

																						External Static Pressure (Pascals)									
		275		300		325		350		375		400		425		450		475		500											
m <sup>3</sup> /h	rpm	kW	rpm	kW	rpm	kW	rpm	kW	rpm	kW	rpm	kW	rpm	kW	rpm	kW	rpm	kW	rpm	kW											
<b>1.50 Nom kW Std Motor &amp; Drive</b>											<b>1.50 Nom kW Std Motor &amp; Field Supplied High Static Drive or 2.24 Nom kW Oversized Motor &amp; Drive<sup>(d)</sup></b>																				
4080	1089	0.97	1127	1.05	1162	1.13	1194	1.20	1227	1.27	1259	1.35	1289	1.43	1317	1.50	1346	1.58	1374	1.66											
4590	1118	1.14	1154	1.22	1190	1.30	1227	1.39	1261	1.48	1292	1.56	1323	1.65	1352	1.73	1382	1.82	1408	1.90											
5100	1156	1.35	1189	1.43	1222	1.51	1254	1.60	1289	1.69	1320	1.78	1353	1.88	1386	1.98	1414	2.07	1444	2.17											
5610	1204	1.60	1232	1.68	1262	1.77	1293	1.86	1323	1.95	1353	2.04	1382	2.13	1413	2.23	1442	2.33	—	—											
6120	1256	1.91	1283	1.99	1311	2.08	1337	2.16	1364	2.26	1392	2.35	1420	2.45	1447	2.55	—	—	—	—											
<b>2.24 Nom kW Oversized Motor &amp; Drive<sup>(e)</sup></b>																															

**Notes:**

1. For Standard Evaporator Fan Speed (RPM), reference [Table 97, p. 117](#).
2. Data includes pressure drop due to standard filters and wet coils.
3. Refer to [Table 107, p. 119](#) to determine additional static pressure drop due to other options/accessories.
4. 1.50 kW Fan Motor Heat (kW) = 1.20 x Fan kW + .06. 2.24 kW Fan Motor Heat (kW) = 1.140 x kW - .110.
5. Factory supplied motors, in commercial equipment, are definite purpose motors, specifically designed and tested to operate reliably and continuously at all cataloged conditions. Using the full horsepower range of our fan motors as shown in our tabular data will not result in nuisance tripping or premature motor failure. Our product's warranty will not be affected.

(a) BAYLSDR005A  
 (b) BAYHSDR013A (or 2.24 Nom kW Oversized Motor and Drive)  
 (c) BAYHSMT097A  
 (d) BAYHSDR013A (or 2.24 Nom kW Oversized Motor and Drive)  
 (e) BAYHSMT097A



## Evaporator Fan Performance

**Table 36. Belt drive evaporator fan performance—7½ tons—TSC090ED—horizontal airflow (IP)**

External Static Pressure (Inches of Water)																					
		.10		.20		.30		.40		.50		.60		.70		.80		.90		1.00	
cfm	rpm	bhp	rpm	bhp	rpm	bhp	rpm	bhp	rpm	bhp	rpm	bhp	rpm	bhp	rpm	bhp	rpm	bhp	rpm	bhp	
2-hp Std Motor & Field Supplied Low Static Drive <sup>(a)</sup>											2-hp Std Motor & Drive										
2400	—	—	706	0.54	753	0.61	799	0.69	842	0.77	883	0.84	924	0.92	965	1.01	1005	1.10	1047	1.20	
2700	720	0.63	770	0.72	814	0.81	856	0.89	896	0.97	935	1.06	972	1.15	1007	1.23	1044	1.33	1080	1.43	
3000	789	0.85	835	0.95	877	1.04	917	1.14	953	1.23	989	1.32	1025	1.42	1059	1.51	1091	1.61	1123	1.71	
3300	858	1.10	901	1.22	941	1.32	978	1.43	1014	1.53	1047	1.63	1080	1.73	1112	1.83	1144	1.94	1175	2.05	
3600	928	1.41	969	1.53	1006	1.65	1042	1.77	1076	1.88	1107	1.99	1138	2.10	1168	2.21	1198	2.32	1227	2.44	
2-hp Std Motor & Field Supplied High Static Drive or 3-hp Oversized Motor & Drive <sup>(b)</sup>											3-hp Oversized Motor & Drive <sup>(c)</sup>										

Continued

External Static Pressure (Inches of Water)																					
		1.10		1.20		1.30		1.40		1.50		1.60		1.70		1.80		1.90		2.00	
cfm	rpm	bhp	rpm	bhp	rpm	bhp	rpm	bhp	rpm	bhp	rpm	bhp	rpm	bhp	rpm	bhp	rpm	bhp	rpm	bhp	
2-hp Std Motor & Drive						2-hp Std Motor & Field Supplied High Static Drive or 3-hp Oversized Motor & Drive <sup>(d)</sup>															
2400	1089	1.31	1127	1.41	1162	1.51	1194	1.60	1227	1.71	1259	1.81	1289	1.91	1317	2.01	1346	2.12	1374	2.23	
2700	1118	1.53	1154	1.63	1190	1.75	1227	1.87	1261	1.99	1292	2.10	1323	2.21	1352	2.32	1382	2.44	1408	2.54	
3000	1156	1.81	1189	1.92	1222	2.03	1254	2.14	1289	2.27	1320	2.39	1353	2.52	1386	2.66	1414	2.78	1444	2.91	
3300	1204	2.15	1232	2.26	1262	2.37	1293	2.50	1323	2.62	1353	2.74	1382	2.86	1413	2.99	1442	3.13	—	—	
3600	1256	2.55	1283	2.67	1311	2.78	1337	2.90	1364	3.02	1392	3.15	1420	3.29	1447	3.42	—	—	—	—	
3-hp Oversized Motor & Drive <sup>(e)</sup>																					

**Notes:**

1. For Standard Evaporator Fan Speed (RPM), reference [Table 97, p. 117](#).
2. Data includes pressure drop due to standard filters and wet coils.
3. Refer to [Table 108, p. 119](#) to determine additional static pressure drop due to other options/accessories.
4. 2-hp Fan Motor Heat (MBh) = 3.100 x Fan bhp + .200. 3-hp Fan Motor Heat (MBh) = 2.900 x Fan bhp - .3800.
5. Factory supplied motors, in commercial equipment, are definite purpose motors, specifically designed and tested to operate reliably and continuously at all cataloged conditions. Using the full horsepower range of our fan motors as shown in our tabular data will not result in nuisance tripping or premature motor failure. Our product's warranty will not be affected.

- (a) BAYLSDR005A  
 (b) BAYHSDR013A (or 3-hp Oversized Motor and Drive)  
 (c) BAYHSMT097A  
 (d) BAYHSDR013A (or 3-hp Oversized Motor and Drive)  
 (e) BAYHSMT097A

## Evaporator Fan Performance

**Table 37. Belt drive evaporator fan performance—7½ tons—YSC090ED—low gas heat—downflow airflow (SI)**

																						External Static Pressure (Pascals)									
		25		50		75		100		125		150		175		200		225		250											
m <sup>3</sup> /h	rpm	kW	rpm	kW	rpm	kW	rpm	kW	rpm	kW	rpm	kW	rpm	kW	rpm	kW	rpm	kW	rpm	kW											
<b>1.50 Nom kW Std Motor &amp; Field Supplied Low Static Drive<sup>(a)</sup></b>											<b>1.50 Nom kW Std Motor &amp; Drive</b>																				
4080	—	—	691	0.39	739	0.44	785	0.50	829	0.56	870	0.61	910	0.67	948	0.74	985	0.80	1021	0.86											
4590	702	0.46	753	0.52	798	0.59	840	0.65	880	0.71	920	0.77	957	0.84	993	0.90	1029	0.97	1062	1.04											
5100	768	0.61	815	0.68	858	0.75	898	0.82	936	0.89	972	0.96	1008	1.03	1042	1.10	1076	1.17	1108	1.24											
5610	835	0.79	880	0.88	920	0.96	958	1.03	993	1.11	1027	1.18	1061	1.26	1094	1.33	1126	1.41	<sup>(b)</sup> 1156	1.49											
6120	903	1.01	945	1.11	983	1.19	1019	1.28	1053	1.36	1085	1.44	1116	1.52	1148	1.60	1178	1.69	1207	1.77											
<b>1.50 Nom kW Std Motor &amp; Field Supplied High Static Drive or 2.24 Nom kW Oversized Motor &amp; Drive<sup>(c)</sup></b>											<b>2.24 Nom kW Oversized Motor &amp; Drive<sup>(d)</sup></b>																				

Continued

																						External Static Pressure (Pascals)									
		275		300		325		350		375		400		425		450		475		500											
m <sup>3</sup> /h	rpm	kW	rpm	kW	rpm	kW	rpm	kW	rpm	kW	rpm	kW	rpm	kW	rpm	kW	rpm	kW	rpm	kW											
<b>1.50 Nom kW Std Motor &amp; Drive</b>							<b>1.50 Nom kW Std Motor &amp; Field Supplied High Static Drive or 2.24 Nom kW Oversized Motor &amp; Drive<sup>(e)</sup></b>																								
4080	1055	0.92	1086	0.98	1117	1.04	1148	1.11	1175	1.17	1204	1.23	1231	1.29	1257	1.36	1284	1.42	1308	1.48											
4590	1096	1.11	1128	1.17	1158	1.24	1189	1.31	1217	1.38	1245	1.46	1271	1.52	1299	1.60	1324	1.67	1348	1.74											
5100	1140	1.32	1171	1.40	1199	1.47	1230	1.55	1258	1.62	1286	1.70	1314	1.78	1339	1.86	1365	1.94	1388	2.01											
5610	1186	1.57	1216	1.64	1244	1.73	1273	1.81	1300	1.90	1328	1.99	1354	2.07	1381	2.15	1405	2.23	1430	2.32											
6120	1236	1.86	1264	1.94	1291	2.02	1318	2.11	1345	2.20	1372	2.29	1397	2.39	1422	2.48	1447	2.57	—	—											
<b>2.24 Nom kW Oversized Motor &amp; Drive<sup>(f)</sup></b>																															

**Notes:**

1. For Standard Evaporator Fan Speed (RPM), reference [Table 97, p. 117](#).
2. Data includes pressure drop due to standard filters and wet coils.
3. Refer to [Table 107, p. 119](#) to determine additional static pressure drop due to other options/accessories.
4. 1.50 kW Fan Motor Heat (kW) = 1.20 x Fan kW + .06. 2.24 kW Fan Motor Heat (kW) = 1.140 x kW - .110.
5. Factory supplied motors, in commercial equipment, are definite purpose motors, specifically designed and tested to operate reliably and continuously at all cataloged conditions. Using the full horsepower range of our fan motors as shown in our tabular data will not result in nuisance tripping or premature motor failure. Our product's warranty will not be affected.

(a) BAYLSDR005A  
 (b) BAYHSDR013A (or 2.24 Nom kW Oversized Motor and Drive)  
 (c) BAYHSDR013A (or 2.24 Nom kW Oversized Motor and Drive)  
 (d) BAYHSMT097A  
 (e) BAYHSDR013A (or 2.24 Nom kW Oversized Motor and Drive)  
 (f) BAYHSMT097A



## Evaporator Fan Performance

**Table 38. Belt drive evaporator fan performance—7½ tons—YSC090ED—low gas heat—downflow airflow (IP)**

External Static Pressure (Inches of Water)																						
		.10		.20		.30		.40		.50		.60		.70		.80		.90		1.00		
cfm	rpm	bhp	rpm	bhp	rpm	bhp	rpm	bhp	rpm	bhp	rpm	bhp	rpm	bhp	rpm	bhp	rpm	bhp	rpm	bhp	rpm	bhp
2-hp Std Motor & Field Supplied Low Static Drive <sup>(a)</sup>											2-hp Std Motor & Drive											
2400	—	—	691	0.52	739	0.60	785	0.67	829	0.75	870	0.82	910	0.90	948	0.99	985	1.07	1021	1.15		
2700	702	0.61	753	0.70	798	0.78	840	0.87	880	0.95	920	1.04	957	1.12	993	1.20	1029	1.30	1062	1.39		
3000	768	0.82	815	0.92	858	1.01	898	1.10	936	1.19	972	1.29	1008	1.38	1042	1.48	1076	1.57	1108	1.66		
3300	835	1.06	880	1.18	920	1.28	958	1.38	993	1.48	1027	1.58	1061	1.68	1094	1.79	1126	1.90	(b)1156	2.00		
3600	903	1.36	945	1.48	983	1.60	1019	1.71	1053	1.82	1085	1.93	1116	2.04	1148	2.15	1178	2.26	1207	2.38		
2-hp Std Motor & Field Supplied High Static Drive or 3-hp Oversized Motor & Drive <sup>(c)</sup>											3-hp Oversized Motor & Drive <sup>(d)</sup>											

Continued

External Static Pressure (Inches of Water)																						
		1.10		1.20		1.30		1.40		1.50		1.60		1.70		1.80		1.90		2.00		
cfm	rpm	bhp	rpm	bhp	rpm	bhp	rpm	bhp	rpm	bhp	rpm	bhp	rpm	bhp	rpm	bhp	rpm	bhp	rpm	bhp	rpm	bhp
2-hp Std Motor & Drive						2-hp Std Motor & Field Supplied High Static Drive or 3-hp Oversized Motor & Drive <sup>(e)</sup>																
2400	1055	1.23	1086	1.31	1117	1.40	1148	1.49	1175	1.57	1204	1.65	1231	1.73	1257	1.82	1284	1.90	1308	1.98		
2700	1096	1.48	1128	1.57	1158	1.66	1189	1.76	1217	1.86	1245	1.95	1271	2.04	1299	2.14	1324	2.24	1348	2.33		
3000	1140	1.77	1171	1.88	1199	1.98	1230	2.08	1258	2.18	1286	2.28	1314	2.39	1339	2.49	1365	2.60	1388	2.70		
3300	1186	2.10	1216	2.20	1244	2.31	1273	2.43	1300	2.55	1328	2.66	1354	2.77	1381	2.88	1405	2.99	1430	3.10		
3600	1236	2.49	1264	2.61	1291	2.71	1318	2.83	1345	2.94	1372	3.08	1397	3.20	1422	3.33	1447	3.45	—	—		
3-hp Oversized Motor & Drive <sup>(f)</sup>																						

**Notes:**

1. For Standard Evaporator Fan Speed (RPM), reference [Table 97, p. 117](#).
2. Data includes pressure drop due to standard filters and wet coils.
3. Refer to [Table 108, p. 119](#) to determine additional static pressure drop due to other options/accessories.
4. 2-hp Fan Motor Heat (MBh) = 3.100 x Fan bhp + .200. 3-hp Fan Motor Heat (MBh) = 2.900 x Fan bhp - .3800.
5. Factory supplied motors, in commercial equipment, are definite purpose motors, specifically designed and tested to operate reliably and continuously at all cataloged conditions. Using the full horsepower range of our fan motors as shown in our tabular data will not result in nuisance tripping or premature motor failure. Our product's warranty will not be affected.

- (a) BAYLSDR005A
- (b) BAYHSDR013A (or 3-hp Oversized Motor and Drive)
- (c) BAYHSDR013A (or 3-hp Oversized Motor and Drive)
- (d) BAYHSMT097A
- (e) BAYHSDR013A (or 3-hp Oversized Motor and Drive)
- (f) BAYHSMT097A

## Evaporator Fan Performance

**Table 39. Belt drive evaporator fan performance—7½ tons—YSC090ED—high gas heat—downflow airflow (SI)**

																						External Static Pressure (Pascals)									
		25		50		75		100		125		150		175		200		225		250											
m <sup>3</sup> /h	rpm	kW	rpm	kW	rpm	kW	rpm	kW	rpm	kW	rpm	kW	rpm	kW	rpm	kW	rpm	kW	rpm	kW											
<b>1.50 Nom kW Std Motor &amp; Field Supplied Low Static Drive<sup>(a)</sup></b>											<b>1.50 Nom kW Std Motor &amp; Drive</b>																				
4080	703	0.39	751	0.44	799	0.49	844	0.55	887	0.61	928	0.67	968	0.73	1007	0.79	1045	0.85	1081	0.91											
4590	778	0.54	823	0.59	865	0.65	907	0.71	948	0.78	986	0.84	1022	0.91	1059	0.98	1094	1.04	1129	1.11											
5100	855	0.72	896	0.78	935	0.84	972	0.91	1010	0.98	1047	1.06	1081	1.13	1115	1.20	1148	1.27	1180	1.35											
5610	932	0.94	970	1.01	1006	1.08	1041	1.15	1075	1.23	1109	1.31	1143	1.39	1175	1.47	1206	1.55	1236	1.62											
6120	1009	1.21	1045	1.29	1079	1.36	1111	1.43	1143	1.51	1175	1.60	1206	1.68	1237	1.77	1267	1.86	1295	1.94											
<b>1.50 Nom kW Std Motor &amp; Field Supplied High Static Drive or 2.24 Nom kW Oversized Motor &amp; Drive<sup>(b)</sup></b>											<b>2.24 Nom kW Oversized Motor &amp; Drive<sup>(c)</sup></b>																				

Continued

																						External Static Pressure (Pascals)									
		275		300		325		350		375		400		425		450		475		500											
m <sup>3</sup> /h	rpm	kW	rpm	kW	rpm	kW	rpm	kW	rpm	kW	rpm	kW	rpm	kW	rpm	kW	rpm	kW	rpm	kW											
<b>1.50 Nom kW Std Motor &amp; Drive</b>											<b>1.50 Nom kW Std Motor &amp; Field Supplied High Static Drive or 2.24 Nom kW Oversized Motor &amp; Drive<sup>(d)</sup></b>																				
4080	1115	0.98	1148	1.04	1181	1.11	1212	1.17	1243	1.24	1271	1.30	1299	1.37	1327	1.43	1355	1.50	1380	1.56											
4590	1163	1.18	1195	1.25	1227	1.33	1257	1.40	1287	1.47	1317	1.55	1344	1.62	1371	1.69	1398	1.77	1425	1.84											
5100	1212	1.42	1243	1.50	1274	1.58	1304	1.65	1333	1.74	1362	1.82	1389	1.90	1415	1.98	1443	2.06	—	—											
5610	1266	1.71	1296	1.79	1324	1.87	1353	1.95	1382	2.04	1410	2.12	1437	2.21	—	—	—	—	—	—											
6120	1323	2.03	1352	2.12	1378	2.21	1405	2.30	1432	2.38	—	—	—	—	—	—	—	—	—	—											
<b>2.24 Nom kW Oversized Motor &amp; Drive<sup>(e)</sup></b>																															

**Notes:**

1. For Standard Evaporator Fan Speed (RPM), reference [Table 97, p. 117](#).
2. Data includes pressure drop due to standard filters and wet coils.
3. Refer to [Table 107, p. 119](#) to determine additional static pressure drop due to other options/accessories.
4. 1.50 kW Fan Motor Heat (kW) = 1.20 x Fan kW + .06. 2.24 kW Fan Motor Heat (kW) = 1.140 x kW - .110.
5. Factory supplied motors, in commercial equipment, are definite purpose motors, specifically designed and tested to operate reliably and continuously at all cataloged conditions. Using the full horsepower range of our fan motors as shown in our tabular data will not result in nuisance tripping or premature motor failure. Our product's warranty will not be affected.

(a) BAYLSDR005A  
 (b) BAYHSDR013A (or 2.24 Nom kW Oversized Motor and Drive)  
 (c) BAYHSMT097A  
 (d) BAYHSDR013A (or 2.24 Nom kW Oversized Motor and Drive)  
 (e) BAYHSMT097A



## Evaporator Fan Performance

**Table 40. Belt drive evaporator fan performance—7½ tons—YSC090ED—high gas heat—downflow airflow (IP)**

External Static Pressure (Inches of Water)																					
		.10		.20		.30		.40		.50		.60		.70		.80		.90		1.00	
cfm	rpm	bhp	rpm	bhp	rpm	bhp	rpm	bhp	rpm	bhp	rpm	bhp	rpm	bhp	rpm	bhp	rpm	bhp	rpm	bhp	
2-hp Std Motor & Field Supplied Low Static Drive <sup>(a)</sup>											2-hp Std Motor & Drive										
2400	703	0.52	751	0.58	799	0.66	844	0.74	887	0.82	928	0.89	968	0.97	1007	1.05	1045	1.14	1081	1.22	
2700	778	0.72	823	0.79	865	0.87	907	0.96	948	1.05	986	1.13	1022	1.22	1059	1.31	1094	1.40	1129	1.49	
3000	855	0.96	896	1.05	935	1.13	972	1.22	1010	1.32	1047	1.42	1081	1.51	1115	1.61	1148	1.71	1180	1.81	
3300	932	1.26	970	1.36	1006	1.45	1041	1.54	1075	1.65	1109	1.75	1143	1.86	1175	1.97	1206	2.07	1236	2.18	
3600	1009	1.62	1045	1.72	1079	1.83	1111	1.92	1143	2.03	1175	2.14	1206	2.26	1237	2.37	1267	2.49	1295	2.61	
											2-hp Std Motor & Field Supplied High Static Drive or 3-hp Oversized Motor & Drive <sup>(b)</sup>										
											3-hp Oversized Motor & Drive <sup>(c)</sup>										

Continued

External Static Pressure (Inches of Water)																					
		1.10		1.20		1.30		1.40		1.50		1.60		1.70		1.80		1.90		2.00	
cfm	rpm	bhp	rpm	bhp	rpm	bhp	rpm	bhp	rpm	bhp	rpm	bhp	rpm	bhp	rpm	bhp	rpm	bhp	rpm	bhp	
2-hp Std Motor & Drive						2-hp Std Motor & Field Supplied High Static Drive or 3-hp Oversized Motor & Drive <sup>(d)</sup>															
2400	1115	1.31	1148	1.40	1181	1.49	1212	1.57	1243	1.66	1271	1.75	1299	1.83	1327	1.92	1355	2.01	1380	2.10	
2700	1163	1.59	1195	1.68	1227	1.78	1257	1.87	1287	1.97	1317	2.08	1344	2.17	1371	2.27	1398	2.37	1425	2.47	
3000	1212	1.91	1243	2.01	1274	2.11	1304	2.22	1333	2.33	1362	2.44	1389	2.54	1415	2.65	1443	2.76	—	—	
3300	1266	2.29	1296	2.40	1324	2.51	1353	2.62	1382	2.73	1410	2.85	1437	2.96	—	—	—	—	—	—	
3600	1323	2.72	1352	2.84	1378	2.96	1405	3.08	1432	3.20	—	—	—	—	—	—	—	—	—	—	
											3-hp Oversized Motor & Drive <sup>(e)</sup>										

**Notes:**

1. For Standard Evaporator Fan Speed (RPM), reference [Table 97, p. 117](#).
2. Data includes pressure drop due to standard filters and wet coils.
3. Refer to [Table 108, p. 119](#) to determine additional static pressure drop due to other options/accessories.
4. 2-hp Fan Motor Heat (MBh) = 3.100 x Fan bhp + .200. 3-hp Fan Motor Heat (MBh) = 2.900 x Fan bhp - .3800.
5. Factory supplied motors, in commercial equipment, are definite purpose motors, specifically designed and tested to operate reliably and continuously at all cataloged conditions. Using the full horsepower range of our fan motors as shown in our tabular data will not result in nuisance tripping or premature motor failure. Our product's warranty will not be affected.

- (a) BAYLSDR005A  
 (b) BAYHSDR013A (or 3-hp Oversized Motor and Drive)  
 (c) BAYHSMT097A  
 (d) BAYHSDR013A (or 3-hp Oversized Motor and Drive)  
 (e) BAYHSMT097A



## Evaporator Fan Performance

**Table 41. Belt drive evaporator fan performance—7½ tons—YSC090ED—low gas heat—horizontal airflow (SI)**

																						External Static Pressure (Pascals)									
		25		50		75		100		125		150		175		200		225		250											
m <sup>3</sup> /h	rpm	kW	rpm	kW	rpm	kW	rpm	kW	rpm	kW	rpm	kW	rpm	kW	rpm	kW	rpm	kW	rpm	kW											
<b>1.50 Nom kW Std Motor &amp; Field Supplied Low Static Drive<sup>(a)</sup></b>											<b>1.50 Nom kW Std Motor &amp; Drive</b>																				
4080	717	0.41	768	0.48	815	0.54	858	0.60	899	0.65	938	0.71	976	0.78	1011	0.84	1047	0.90	1080	0.97											
4590	793	0.57	841	0.64	884	0.71	924	0.78	963	0.84	1000	0.91	1035	0.98	1069	1.04	1102	1.11	1134	1.19											
5100	871	0.76	915	0.84	955	0.92	993	1.00	1029	1.07	1064	1.14	1097	1.22	1129	1.29	<sup>(b)</sup> 1161	1.36	1192	1.44											
5610	949	1.00	990	1.09	1028	1.17	1064	1.26	1097	1.34	1130	1.42	1162	1.50	1193	1.58	1223	1.66	1252	1.74											
6120	1028	1.28	1066	1.37	1102	1.47	1136	1.56	1168	1.65	1199	1.74	1229	1.83	1258	1.92	1287	2.01	1314	2.09											
<b>1.50 Nom kW Std Motor &amp; Field Supplied High Static Drive or 2.24 Nom kW Oversized Motor &amp; Drive<sup>(c)</sup></b>											<b>2.24 Nom kW Oversized Motor &amp; Drive<sup>(d)</sup></b>																				

**Continued**

																						External Static Pressure (Pascals)									
		275		300		325		350		375		400		425		450		475		500											
m <sup>3</sup> /h	rpm	kW	rpm	kW	rpm	kW	rpm	kW	rpm	kW	rpm	kW	rpm	kW	rpm	kW	rpm	kW	rpm	kW											
<b>1.50 Nom kW Std Motor &amp; Drive</b>							<b>1.50 Nom kW Std Motor &amp; Field Supplied High Static Drive or 2.24 Nom kW Oversized Motor &amp; Drive<sup>(e)</sup></b>																								
4080	1113	1.04	1146	1.10	1176	1.16	1205	1.22	1234	1.29	1261	1.36	1288	1.43	1316	1.50	1341	1.57	1366	1.64											
4590	1166	1.26	1196	1.33	1226	1.41	1255	1.48	1282	1.55	1310	1.62	1337	1.69	1363	1.76	1388	1.84	1414	1.92											
5100	1222	1.52	1251	1.60	1280	1.68	1308	1.76	1334	1.84	1360	1.92	1387	2.01	1413	2.09	1437	2.16	—	—											
5610	1280	1.82	1308	1.91	1336	2.00	1362	2.08	1389	2.17	1414	2.26	1438	2.35	—	—	—	—	—	—											
6120	1342	2.18	1368	2.27	1395	2.36	1420	2.45	1446	2.55	—	—	—	—	—	—	—	—	—	—											
<b>2.24 Nom kW Oversized Motor &amp; Drive<sup>(f)</sup></b>																															

**Notes:**

1. For Standard Evaporator Fan Speed (RPM), reference [Table 97, p. 117](#).
2. Data includes pressure drop due to standard filters and wet coils.
3. Refer to [Table 107, p. 119](#) to determine additional static pressure drop due to other options/accessories.
4. 1.50 kW Fan Motor Heat (kW) = 1.20 x Fan kW + .06. 2.24 kW Fan Motor Heat (kW) = 1.140 x kW - .110.
5. Factory supplied motors, in commercial equipment, are definite purpose motors, specifically designed and tested to operate reliably and continuously at all cataloged conditions. Using the full horsepower range of our fan motors as shown in our tabular data will not result in nuisance tripping or premature motor failure. Our product's warranty will not be affected.

(a) BAYLSDR005A  
 (b) BAYHSDR013A (or 2.24 Nom kW Oversized Motor and Drive)  
 (c) BAYHSDR013A (or 2.24 Nom kW Oversized Motor and Drive)  
 (d) BAYHSMT097A  
 (e) BAYHSDR013A (or 2.24 Nom kW Oversized Motor and Drive)  
 (f) BAYHSMT097A



## Evaporator Fan Performance

**Table 42. Belt drive evaporator fan performance—7½ tons—YSC090ED—low gas heat—horizontal airflow (IP)**

External Static Pressure (Inches of Water)																						
		.10		.20		.30		.40		.50		.60		.70		.80		.90		1.00		
cfm	rpm	bhp	rpm	bhp	rpm	bhp	rpm	bhp	rpm	bhp	rpm	bhp	rpm	bhp	rpm	bhp	rpm	bhp	rpm	bhp	rpm	bhp
2-hp Std Motor & Field Supplied Low Static Drive <sup>(a)</sup>											2-hp Std Motor & Drive											
2400	717	0.56	768	0.64	815	0.72	858	0.80	899	0.87	938	0.96	976	1.04	1011	1.12	1047	1.21	1080	1.30		
2700	793	0.76	841	0.86	884	0.95	924	1.04	963	1.13	1000	1.22	1035	1.31	1069	1.40	1102	1.49	1134	1.59		
3000	871	1.02	915	1.13	955	1.23	993	1.34	1029	1.44	1064	1.53	1097	1.63	1129	1.73	<sup>(b)</sup> 1161	1.83	1192	1.93		
3300	949	1.34	990	1.46	1028	1.57	1064	1.68	1097	1.79	1130	1.91	1162	2.02	1193	2.12	1223	2.23	1252	2.33		
3600	1028	1.71	1066	1.84	1102	1.97	1136	2.09	1168	2.22	1199	2.34	1229	2.46	1258	2.58	1287	2.69	1314	2.80		
											2-hp Std Motor & Field Supplied High Static Drive or 3-hp Oversized Motor & Drive <sup>(c)</sup>											
											3-hp Oversized Motor & Drive <sup>(d)</sup>											

Continued

External Static Pressure (Inches of Water)																						
		1.10		1.20		1.30		1.40		1.50		1.60		1.70		1.80		1.90		2.00		
cfm	rpm	bhp	rpm	bhp	rpm	bhp	rpm	bhp	rpm	bhp	rpm	bhp	rpm	bhp	rpm	bhp	rpm	bhp	rpm	bhp	rpm	bhp
2-hp Std Motor & Drive						2-hp Std Motor & Field Supplied High Static Drive or 3-hp Oversized Motor & Drive <sup>(e)</sup>																
2400	1113	1.39	1146	1.47	1176	1.56	1205	1.64	1234	1.73	1261	1.82	1288	1.91	1316	2.01	1341	2.10	1366	2.20		
2700	1166	1.69	1196	1.79	1226	1.89	1255	1.98	1282	2.08	1310	2.17	1337	2.27	1363	2.36	1388	2.46	1414	2.57		
3000	1222	2.04	1251	2.15	1280	2.25	1308	2.36	1334	2.47	1360	2.58	1387	2.69	1413	2.80	1437	2.90	—	—		
3300	1280	2.45	1308	2.56	1336	2.68	1362	2.79	1389	2.91	1414	3.03	1438	3.14	—	—	—	—	—	—		
3600	1342	2.92	1368	3.04	1395	3.17	1420	3.29	1446	3.42	—	—	—	—	—	—	—	—	—	—		
											3-hp Oversized Motor & Drive <sup>(f)</sup>											

**Notes:**

1. For Standard Evaporator Fan Speed (RPM), reference [Table 97, p. 117](#).
2. Data includes pressure drop due to standard filters and wet coils.
3. Refer to [Table 108, p. 119](#) to determine additional static pressure drop due to other options/accessories.
4. 2-hp Fan Motor Heat (MBh) = 3.100 x Fan bhp + .200. 3-hp Fan Motor Heat (MBh) = 2.900 x Fan bhp - .3800.
5. Factory supplied motors, in commercial equipment, are definite purpose motors, specifically designed and tested to operate reliably and continuously at all cataloged conditions. Using the full horsepower range of our fan motors as shown in our tabular data will not result in nuisance tripping or premature motor failure. Our product's warranty will not be affected.

- (a) BAYLSDR005A  
 (b) BAYHSDR013A (or 3-hp Oversized Motor and Drive)  
 (c) BAYHSDR013A (or 3-hp Oversized Motor and Drive)  
 (d) BAYHSMT097A  
 (e) BAYHSDR013A (or 3-hp Oversized Motor and Drive)  
 (f) BAYHSMT097A

## Evaporator Fan Performance

**Table 43. Belt drive evaporator fan performance—7½ tons—YSC090ED—high gas heat—horizontal airflow (SI)**

																						External Static Pressure (Pascals)									
		25		50		75		100		125		150		175		200		225		250											
m <sup>3</sup> /h	rpm	kW	rpm	kW	rpm	kW	rpm	kW	rpm	kW	rpm	kW	rpm	kW	rpm	kW	rpm	kW	rpm	kW											
<b>1.50 Nom kW Std Motor &amp; Field Supplied Low Static Drive<sup>(a)</sup></b>											<b>1.50 Nom kW Std Motor &amp; Drive</b>																				
4080	773	0.47	821	0.53	864	0.59	905	0.65	945	0.71	984	0.77	1021	0.83	1055	0.89	1088	0.96	1120	1.02											
4590	857	0.65	901	0.71	942	0.78	980	0.85	1016	0.91	1052	0.99	1087	1.06	1120	1.13	1153	1.20	1183	1.26											
5100	943	0.87	983	0.94	1022	1.02	1057	1.10	1090	1.17	1124	1.24	1156	1.32	1187	1.40	1219	1.48	1248	1.55											
5610	1029	1.14	1066	1.22	1102	1.30	1136	1.39	1168	1.47	1198	1.55	1228	1.63	1257	1.72	1286	1.80	1315	1.89											
6120	1116	1.47	1151	1.55	1184	1.64	1216	1.73	1246	1.83	1275	1.92	1303	2.00	1330	2.09	1357	2.18	1385	2.27											
<b>1.50 Nom kW Std Motor &amp; Field Supplied High Static Drive or 2.24 Nom kW Oversized Motor &amp; Drive<sup>(b)</sup></b>											<b>2.24 Nom kW Oversized Motor &amp; Drive<sup>(c)</sup></b>																				

Continued

																						External Static Pressure (Pascals)									
		275		300		325		350		375		400		425		450		475		500											
m <sup>3</sup> /h	rpm	kW	rpm	kW	rpm	kW	rpm	kW	rpm	kW	rpm	kW	rpm	kW	rpm	kW	rpm	kW	rpm	kW											
<b>1.50 Nom kW Std Motor &amp; Drive</b>							<b>1.50 Nom kW Std Motor &amp; Field Supplied High Static Drive or 2.24 Nom kW Oversized Motor &amp; Drive<sup>(d)</sup></b>																								
4080	1151	1.08	1183	1.15	1212	1.21	1242	1.28	1270	1.35	1297	1.41	1324	1.48	1349	1.54	1376	1.61	1400	1.67											
4590	1213	1.33	1241	1.40	1269	1.47	1297	1.55	1325	1.62	1352	1.69	1379	1.77	1405	1.84	1429	1.92	—	—											
5100	1278	1.63	1305	1.70	1332	1.78	1359	1.86	1384	1.94	1409	2.02	1435	2.10	—	—	—	—	—	—											
5610	1343	1.98	1370	2.06	1398	2.15	1423	2.23	1448	2.31	—	—	—	—	—	—	—	—	—	—											
6120	1411	2.37	1438	2.47	—	—	—	—	—	—	—	—	—	—	—	—	—	—	—	—											
<b>2.24 Nom kW Oversized Motor &amp; Drive<sup>(e)</sup></b>																															

**Notes:**

1. For Standard Evaporator Fan Speed (RPM), reference [Table 97, p. 117](#).
2. Data includes pressure drop due to standard filters and wet coils.
3. Refer to [Table 107, p. 119](#) to determine additional static pressure drop due to other options/accessories.
4. 1.50 kW Fan Motor Heat (kW) = 1.20 x Fan kW + .06. 2.24 kW Fan Motor Heat (kW) = 1.140 x kW - .110.
5. Factory supplied motors, in commercial equipment, are definite purpose motors, specifically designed and tested to operate reliably and continuously at all cataloged conditions. Using the full horsepower range of our fan motors as shown in our tabular data will not result in nuisance tripping or premature motor failure. Our product's warranty will not be affected.

(a) BAYLSDR005A  
 (b) BAYHSDR013A (or 2.24 Nom kW Oversized Motor and Drive)  
 (c) BAYHSMT097A  
 (d) BAYHSDR013A (or 2.24 Nom kW Oversized Motor and Drive)  
 (e) BAYHSMT097A



## Evaporator Fan Performance

**Table 44. Belt drive evaporator fan performance—7½ tons—YSC090ED—high gas heat—horizontal airflow (IP)**

External Static Pressure (Inches of Water)																								
		.10		.20		.30		.40		.50		.60		.70		.80		.90		1.00				
cfm	rpm	bhp	rpm	bhp	rpm	bhp	rpm	bhp	rpm	bhp	rpm	bhp	rpm	bhp	rpm	bhp	rpm	bhp	rpm	bhp	rpm	bhp		
2-hp Std Motor & Field Supplied Low Static Drive <sup>(a)</sup>											2-hp Std Motor & Drive													
2400	773	0.62	821	0.71	864	0.79	905	0.86	945	0.95	984	1.03	1021	1.12	1055	1.20	1088	1.28	1120	1.36				
2700	857	0.87	901	0.96	942	1.05	980	1.14	1016	1.23	1052	1.32	1087	1.42	1120	1.51	1153	1.60	1183	1.69				
3000	943	1.17	983	1.26	1022	1.37	1057	1.47	1090	1.57	1124	1.66	1156	1.77	1187	1.88	1219	1.98	1248	2.08				
3300	1029	1.53	1066	1.64	1102	1.75	1136	1.86	<sup>(b)</sup> 1168	1.97	1198	2.08	1228	2.18	1257	2.30	1286	2.41	1315	2.53				
3600	1116	1.96	1151	2.08	1184	2.20	1216	2.32	1246	2.45	1275	2.57	1303	2.68	1330	2.80	1357	2.92	1385	3.05				
2-hp Std Motor & Field Supplied High Static Drive or 3-hp Oversized Motor & Drive <sup>(c)</sup>											3-hp Oversized Motor & Drive <sup>(d)</sup>													

Continued

External Static Pressure (Inches of Water)																								
		1.10		1.20		1.30		1.40		1.50		1.60		1.70		1.80		1.90		2.00				
cfm	rpm	bhp	rpm	bhp	rpm	bhp	rpm	bhp	rpm	bhp	rpm	bhp	rpm	bhp	rpm	bhp	rpm	bhp	rpm	bhp	rpm	bhp		
2-hp Std Motor & Field Supplied High Static Drive or 3-hp Oversized Motor & Drive <sup>(e)</sup>																								
2400	1151	1.45	1183	1.54	1212	1.62	1242	1.72	1270	1.80	1297	1.89	1324	1.98	1349	2.06	1376	2.16	1400	2.24				
2700	1213	1.79	1241	1.88	1269	1.97	1297	2.07	1325	2.17	1352	2.27	1379	2.37	1405	2.47	1429	2.57	—	—				
3000	1278	2.19	1305	2.28	1332	2.39	1359	2.49	1384	2.60	1409	2.70	1435	2.81	—	—	—	—	—	—				
3300	1343	2.65	1370	2.76	1398	2.88	1423	2.99	1448	3.10	—	—	—	—	—	—	—	—	—	—				
3600	1411	3.17	1438	3.30	—	—	—	—	—	—	—	—	—	—	—	—	—	—	—	—				
3-hp Oversized Motor & Drive <sup>(f)</sup>																								

**Notes:**

1. For Standard Evaporator Fan Speed (RPM), reference [Table 97, p. 117](#).
2. Data includes pressure drop due to standard filters and wet coils.
3. Refer to [Table 108, p. 119](#) to determine additional static pressure drop due to other options/accessories.
4. 2-hp Fan Motor Heat (MBh) = 3.100 x Fan bhp + .200. 3-hp Fan Motor Heat (MBh) = 2.900 x Fan bhp - .3800.
5. Factory supplied motors, in commercial equipment, are definite purpose motors, specifically designed and tested to operate reliably and continuously at all cataloged conditions. Using the full horsepower range of our fan motors as shown in our tabular data will not result in nuisance tripping or premature motor failure. Our product's warranty will not be affected.

- (a) BAYLSDR005A
- (b) BAYHSDR013A (or 3-hp Oversized Motor and Drive)
- (c) BAYHSDR013A (or 3-hp Oversized Motor and Drive)
- (d) BAYHSMT097A
- (e) BAYHSDR013A (or 3-hp Oversized Motor and Drive)
- (f) BAYHSMT097A

## Evaporator Fan Performance

**Table 45. Belt drive evaporator fan performance—7½ tons—WSC090ED—downflow airflow (SI)**

External Static Pressure (Pascals)																				
25		50		75		100		125		150		175		200		225		250		
m <sup>3</sup> /h	rpm	kW	rpm	kW	rpm	kW	rpm	kW	rpm	kW	rpm	kW	rpm	kW	rpm	kW	rpm	kW	rpm	kW
1.50 Nom kW Std Motor & Field Supplied Low Static Drive <sup>(a)</sup>												1.50 Nom kW Std Motor & Drive								
4080	—	—	670	0.36	720	0.42	767	0.47	811	0.52	852	0.57	892	0.63	930	0.69	966	0.74	1001	0.80
4590	673	0.42	728	0.49	776	0.55	820	0.60	861	0.66	900	0.72	937	0.78	974	0.84	1008	0.90	1042	0.97
5100	736	0.56	787	0.63	832	0.70	874	0.77	912	0.83	950	0.90	986	0.96	1020	1.03	1054	1.10	1085	1.16
5610	799	0.73	847	0.81	890	0.89	930	0.96	967	1.04	1002	1.10	1036	1.18	1069	1.25	1101	1.32	1132	1.39
6120	863	0.92	907	1.02	949	1.10	987	1.19	1023	1.27	1057	1.35	1089	1.42	1120	1.50	1151	1.58	1180	1.66

Continued

External Static Pressure (Pascals)																				
275		300		325		350		375		400		425		450		475		500		
m <sup>3</sup> /h	rpm	kW	rpm	kW	rpm	kW	rpm	kW	rpm	kW	rpm	kW	rpm	kW	rpm	kW	rpm	kW	rpm	kW
1.50 Nom kW Std Motor & Drive							1.50 Nom kW Std Motor & Field Supplied High Static Drive or 2.24 Nom kW Oversized Motor & Drive <sup>(b)</sup>													
4080	1035	0.86	1067	0.91	1099	0.97	1129	1.03	1158	1.09	1187	1.15	1214	1.20	1241	1.26	1267	1.32	1293	1.38
4590	1074	1.03	1107	1.10	1137	1.16	1167	1.22	1196	1.29	1224	1.36	1251	1.42	1276	1.48	1303	1.55	1328	1.61
5100	1117	1.23	1148	1.30	1177	1.37	1206	1.44	1234	1.51	1261	1.58	1289	1.66	1315	1.73	1340	1.80	1365	1.87
5610	1163	1.47	1192	1.54	1220	1.62	1248	1.70	1276	1.77	1302	1.85	1329	1.93	1354	2.00	1379	2.08	1403	2.16
6120	1209	1.74	1238	1.82	1265	1.90	1292	1.98	1319	2.06	1344	2.14	1370	2.23	1395	2.31	1420	2.40	1443	2.48
<b>3-hp Oversized Motor &amp; Drive<sup>(c)</sup></b>																				

**Notes:**

1. For Standard Evaporator Fan Speed (RPM), reference [Table 101, p. 117](#).
2. Data includes pressure drop due to standard filters and wet coils.
3. Refer to [Table 109, p. 120](#) to determine additional static pressure drop due to other options/accessories.
4. 1.50 kW Fan Motor Heat (MBh) = 1.20 x Fan kW + .06. 2.24 kW Fan Motor Heat (kW) = 1.140 x kW - .110.
5. Factory supplied motors, in commercial equipment, are definite purpose motors, specifically designed and tested to operate reliably and continuously at all cataloged conditions. Using the full horsepower range of our fan motors as shown in our tabular data will not result in nuisance tripping or premature motor failure. Our product's warranty will not be affected.

(a) BAYLSDR005A  
 (b) BAYHSDR013A (or 2.24 Nom kW Oversized Motor and Drive)  
 (c) BAYHSMT097A



## Evaporator Fan Performance

**Table 46. Belt drive evaporator fan performance—7½ tons—WSC090ED—downflow airflow (IP)**

External Static Pressure (Inches of Water)																					
		.10		.20		.30		.40		.50		.60		.70		.80		.90		1.00	
cfm	rpm	bhp	rpm	bhp	rpm	bhp	rpm	bhp	rpm	bhp	rpm	bhp	rpm	bhp	rpm	bhp	rpm	bhp	rpm	bhp	
2-hp Std Motor & Field Supplied Low Static Drive <sup>(a)</sup>											2-hp Std Motor & Drive										
2400	—	—	670	0.49	720	0.56	767	0.63	811	0.70	852	0.77	892	0.84	930	0.92	966	0.99	1001	1.07	
2700	673	0.56	728	0.65	776	0.73	820	0.81	861	0.89	900	0.97	937	1.05	974	1.13	1008	1.21	1042	1.30	
3000	736	0.75	787	0.85	832	0.94	874	1.03	912	1.12	950	1.20	986	1.29	1020	1.38	1054	1.47	1085	1.56	
3300	799	0.97	847	1.08	890	1.19	930	1.29	967	1.39	1002	1.48	1036	1.58	1069	1.67	1101	1.77	1132	1.87	
3600	863	1.24	907	1.36	949	1.48	987	1.59	1023	1.70	1057	1.81	1089	1.91	1120	2.01	1151	2.12	1180	2.22	

Continued

External Static Pressure (Inches of Water)																					
		1.10		1.20		1.30		1.40		1.50		1.60		1.70		1.80		1.90		2.00	
cfm	rpm	bhp	rpm	bhp	rpm	bhp	rpm	bhp	rpm	bhp	rpm	bhp	rpm	bhp	rpm	bhp	rpm	bhp	rpm	bhp	
2-hp Std. Motor & Drive <sup>(b)</sup>						2-hp Std Motor & Field Supplied High Static Drive or 3-hp Oversized Motor & Drive <sup>(c)</sup>															
2400	1035	1.15	1067	1.22	1099	1.30	1129	1.38	1158	1.46	1187	1.54	1214	1.61	1241	1.69	1267	1.77	1293	1.85	
2700	1074	1.38	1107	1.47	1137	1.55	1167	1.64	1196	1.73	1224	1.82	1251	1.90	1276	1.99	1303	2.08	1328	2.16	
3000	1117	1.65	1148	1.75	1177	1.84	1206	1.93	1234	2.03	1261	2.12	1289	2.22	1315	2.32	1340	2.42	1365	2.51	
3300	1163	1.97	1192	2.07	1220	2.17	1248	2.27	1276	2.37	1302	2.48	1329	2.58	1354	2.69	1379	2.79	1403	2.90	
3600	1209	2.33	1238	2.44	1265	2.54	1292	2.65	1319	2.76	1344	2.87	1370	2.99	1395	3.10	1420	3.21	1443	3.33	
<b>3-hp Oversized Motor &amp; Drive<sup>(d)</sup></b>																					

**Notes:**

1. For Standard Evaporator Fan Speed (RPM), reference [Table 101, p. 117](#).
2. Data includes pressure drop due to standard filters and wet coils.
3. Refer to [Table 110, p. 120](#) to determine additional static pressure drop due to other options/accessories.
4. 2-hp Fan Motor Heat (MBh) = 3.100 x Fan bhp + .200. 3-hp Fan Motor Heat (Mbh) = 2.900 x Fan bhp - .3800.
5. Factory supplied motors, in commercial equipment, are definite purpose motors, specifically designed and tested to operate reliably and continuously at all cataloged conditions. Using the full horsepower range of our fan motors as shown in our tabular data will not result in nuisance tripping or premature motor failure. Our product's warranty will not be affected.

- (a) BAYLSDR005A  
 (b) BAYHSMT097A  
 (c) BAYHSDR013A (or 3-hp Oversized Motor and Drive)  
 (d) BAYHSMT097A

## Evaporator Fan Performance

**Table 47. Belt drive evaporator fan performance—7½ tons—WSC090ED—horizontal airflow (SI)**

																						External Static Pressure (Pascals)									
		25		50		75		100		125		150		175		200		225		250											
m <sup>3</sup> /h	rpm	kW	rpm	kW	rpm	kW	rpm	kW	rpm	kW	rpm	kW	rpm	kW	rpm	kW	rpm	kW	rpm	kW											
<b>1.50 Nom kW Std Motor &amp; Field Supplied Low Static Drive<sup>(a)</sup></b>											<b>1.50 Nom kW Std Motor &amp; Drive</b>																				
4080	676	0.37	724	0.42	770	0.48	816	0.54	860	0.60	904	0.66	946	0.72	987	0.79	1027	0.86	1065	0.93											
4590	749	0.51	793	0.57	834	0.63	875	0.69	916	0.76	955	0.83	994	0.89	1032	0.97	1069	1.04	1105	1.11											
5100	822	0.69	863	0.75	901	0.82	937	0.89	974	0.96	1011	1.03	1047	1.10	1082	1.18	1117	1.26	<sup>(b)</sup> 1151	1.34											
5610	895	0.90	934	0.97	970	1.05	1003	1.12	1037	1.19	1070	1.27	1103	1.35	1136	1.43	1168	1.51	1200	1.60											
6120	970	1.15	1006	1.23	1039	1.31	1071	1.39	1102	1.47	1132	1.55	1163	1.64	1193	1.72	1224	1.81	1254	1.90											
<b>1.50 Nom kW Std Motor &amp; Field Supplied High Static Drive or 2.24 Nom kW Oversized Motor &amp; Drive<sup>(c)</sup></b>											<b>2.24 Nom kW Oversized Motor &amp; Drive<sup>(d)</sup></b>																				

**Continued**

																						External Static Pressure (Pascals)									
		275		300		325		350		375		400		425		450		475		500											
m <sup>3</sup> /h	rpm	kW	rpm	kW	rpm	kW	rpm	kW	rpm	kW	rpm	kW	rpm	kW	rpm	kW	rpm	kW	rpm	kW											
<b>1.50 Nom kW Std Motor &amp; Drive</b>						<b>1.50 Nom kW Std Motor &amp; Field Supplied High Static Drive or 2.24 Nom kW Oversized Motor &amp; Drive<sup>(e)</sup></b>																									
4080	1103	1.00	1139	1.08	1173	1.15	1206	1.22	1239	1.29	1270	1.37	1300	1.44	1330	1.51	1358	1.59	1386	1.66											
4590	1141	1.19	1176	1.27	1210	1.35	1243	1.44	1275	1.52	1306	1.60	1336	1.68	1365	1.76	1394	1.84	1421	1.93											
5100	1184	1.42	1217	1.50	1249	1.58	1281	1.67	1313	1.76	1343	1.85	1372	1.94	1401	2.03	1430	2.12	—	—											
5610	1232	1.68	1263	1.77	1293	1.86	1324	1.95	1353	2.04	1383	2.14	1412	2.23	1440	2.33	—	—	—	—											
6120	1283	1.99	1312	2.08	1341	2.17	1370	2.27	1398	2.37	1425	2.46	—	—	—	—	—	—	—	—											
<b>2.24 Nom kW Oversized Motor &amp; Drive<sup>(f)</sup></b>																															

**Notes:**

1. For Standard Evaporator Fan Speed (RPM), reference [Table 101, p. 117](#).
2. Data includes pressure drop due to standard filters and wet coils.
3. Refer to [Table 109, p. 120](#) to determine additional static pressure drop due to other options/accessories.
4. 1.50 kW Fan Motor Heat (kW) = 1.20 x Fan kW +.06. 2.24 kW Fan Motor Heat (kW) = 1.140 kW -.110.
5. Factory supplied motors, in commercial equipment, are definite purpose motors, specifically designed and tested to operate reliably and continuously at all cataloged conditions. Using the full horsepower range of our fan motors as shown in our tabular data will not result in nuisance tripping or premature motor failure. Our product's warranty will not be affected.

(a) BAYLSDR005A  
 (b) BAYHSDR013A (or 2.24 Nom kW Oversized Motor and Drive)  
 (c) BAYHSDR013A (or 2.24 Nom kW Oversized Motor and Drive)  
 (d) BAYHSMT097A  
 (e) BAYHSDR013A (or 2.24 Nom kW Oversized Motor and Drive)  
 (f) BAYHSMT097A



## Evaporator Fan Performance

**Table 48. Belt drive evaporator fan performance—7½ tons—WSC090ED—horizontal airflow (IP)**

External Static Pressure (Inches of Water)																						
		.10		.20		.30		.40		.50		.60		.70		.80		.90		1.00		
cfm	rpm	bhp	rpm	bhp	rpm	bhp	rpm	bhp	rpm	bhp	rpm	bhp	rpm	bhp	rpm	bhp	rpm	bhp	rpm	bhp	rpm	bhp
<b>2-hp Std Motor &amp; Field Supplied Low Static Drive<sup>(a)</sup></b>											<b>2-hp Std Motor &amp; Drive</b>											
2400	676	0.50	724	0.57	770	0.64	816	0.72	860	0.80	904	0.88	946	0.97	987	1.06	1027	1.15	1065	1.25		
2700	749	0.69	793	0.77	834	0.85	875	0.93	916	1.02	955	1.11	994	1.20	1032	1.30	1069	1.39	1105	1.49		
3000	822	0.92	863	1.01	901	1.10	937	1.19	974	1.28	1011	1.38	1047	1.48	1082	1.58	1117	1.68	<sup>(b)</sup> 1151	1.79		
3300	895	1.20	934	1.30	970	1.40	1003	1.50	1037	1.60	1070	1.70	1103	1.81	1136	1.92	1168	2.03	1200	2.14		
3600	970	1.54	1006	1.65	1039	1.76	1071	1.87	1102	1.97	1132	2.08	1163	2.19	1193	2.31	1224	2.42	1254	2.54		
<b>2-hp Std Motor &amp; Field Supplied High Static Drive or 3-hp Oversized Motor &amp; Drive<sup>(c)</sup></b>																<b>3-hp Oversized Motor &amp; Drive<sup>(d)</sup></b>						

Continued

External Static Pressure (Inches of Water)																						
		1.10		1.20		1.30		1.40		1.50		1.60		1.70		1.80		1.90		2.00		
cfm	rpm	bhp	rpm	bhp	rpm	bhp	rpm	bhp	rpm	bhp	rpm	bhp	rpm	bhp	rpm	bhp	rpm	bhp	rpm	bhp	rpm	bhp
<b>2-hp Std. Motor &amp; Drive</b>						<b>2-hp Std Motor &amp; Field Supplied High Static Drive or 3-hp Oversized Motor &amp; Drive<sup>(e)</sup></b>																
2400	1103	1.35	1139	1.44	1173	1.54	1206	1.64	1239	1.74	1270	1.83	1300	1.93	1330	2.03	1358	2.13	1386	2.22		
2700	1141	1.60	1176	1.70	1210	1.81	1243	1.92	1275	2.03	1306	2.14	1336	2.25	1365	2.36	1394	2.47	1421	2.58		
3000	1184	1.90	1217	2.01	1249	2.12	1281	2.24	1313	2.36	1343	2.48	1372	2.60	1401	2.72	1430	2.85	—	—		
3300	1232	2.25	1263	2.37	1293	2.49	1324	2.62	1353	2.74	1383	2.87	1412	3.00	1440	3.12	—	—	—	—		
3600	1283	2.66	1312	2.79	1341	2.91	1370	3.04	1398	3.17	1425	3.30	—	—	—	—	—	—	—	—		
<b>3-hp Oversized Motor &amp; Drive<sup>(f)</sup></b>																						

**Notes:**

1. For Standard Evaporator Fan Speed (RPM), reference [Table 101, p. 117](#).
2. Data includes pressure drop due to standard filters and wet coils.
3. Refer to [Table 110, p. 120](#) to determine additional static pressure drop due to other options/accessories.
4. 2-hp Fan Motor Heat (MBh) = 3.100 x Fan bhp + .200. 3-hp Fan Motor Heat (MBh) = 2.900 x Fan bhp - .3800.
5. Factory supplied motors, in commercial equipment, are definite purpose motors, specifically designed and tested to operate reliably and continuously at all cataloged conditions. Using the full horsepower range of our fan motors as shown in our tabular data will not result in nuisance tripping or premature motor failure. Our product's warranty will not be affected.

- (a) BAYLSDR005A  
 (b) BAYHSDR013A (or 3-hp Oversized Motor and Drive)  
 (c) BAYHSDR013A (or 3-hp Oversized Motor and Drive)  
 (d) BAYHSMT097A  
 (e) BAYHSDR013A (or 3-hp Oversized Motor and Drive)  
 (f) BAYHSMT097A



## Evaporator Fan Performance

**Table 49. Belt drive evaporator fan performance—8½ tons—TSC102ED—downflow airflow (SI)**

																						External Static Pressure (Pascals)									
		25		50		75		100		125		150		175		200		225		250											
m <sup>3</sup> /h	rpm	rpm	kW	rpm	kW	rpm	kW	rpm	kW	rpm	kW	rpm	kW	rpm	kW	rpm	kW	rpm	kW	rpm	kW										
																						<b>1.50 Nom kW Std Motor &amp; Field Supplied Low Static Drive<sup>(a)</sup></b>									
4620	—	—	—	—	—	—	—	—	—	615	0.50	652	0.57	688	0.64	723	0.71	757	0.78	790	0.86										
5200	—	—	—	—	—	—	—	609	0.55	644	0.61	681	0.69	714	0.77	747	0.84	779	0.92	810	1.00										
5780	—	—	—	—	613	0.62	647	0.69	678	0.75	710	0.83	744	0.92	774	1.00	804	1.08	833	1.16											
6350	—	—	621	0.71	655	0.78	686	0.86	717	0.93	744	1.00	772	1.07	805	1.17	834	1.27	861	1.36											
6930	629	0.79	664	0.88	697	0.97	727	1.05	755	1.13	784	1.21	808	1.29	833	1.36	862	1.47	892	1.58											
																						<b>1.50 Nom kW Std Motor &amp; Drive</b>									

**Continued**

																						External Static Pressure (Pascals)									
		275		300		325		350		375		400		425		450		475		500											
m <sup>3</sup> /h	rpm	rpm	kW	rpm	kW	rpm	kW	rpm	kW	rpm	kW	rpm	kW	rpm	kW	rpm	kW	rpm	kW	rpm	kW										
										<b>1.50 Nom kW Std Motor &amp; Drive</b>																					
										<b>1.50 Nom kW Std Motor &amp; Field Supplied High Static Drive or 2.24 Nom kW Oversized Motor &amp; Drive<sup>(b)</sup></b>																					
4620	819	0.94	848	1.02	876	1.10	901	1.17	927	1.26	952	1.34	976	1.42	1000	1.51	1023	1.59	1044	1.67											
5200	840	1.08	870	1.16	897	1.25	924	1.34	950	1.43	974	1.52	998	1.61	1021	1.70	1044	1.79	1066	1.89											
5780	862	1.25	891	1.34	918	1.43	944	1.52	972	1.62	996	1.71	1019	1.81	1042	1.91	1066	2.01	1087	2.11											
6350	887	1.45	915	1.54	940	1.63	966	1.73	991	1.83	1016	1.93	1041	2.03	1065	2.13	1088	2.24	1110	2.35											
6930	916	1.67	941	1.77	966	1.87	990	1.97	1015	2.08	1039	2.18	1061	2.28	1084	2.39	1108	2.50	1131	2.61											
																						<b>2.24 Nom kW Oversized Motor &amp; Drive<sup>(c)</sup></b>									

**Notes:**

1. For Standard Evaporator Fan Speed (RPM), reference [Table 97, p. 117](#).
2. Data includes pressure drop due to standard filters and wet coils.
3. Refer to [Table 107, p. 119](#) to determine additional static pressure drop due to other options/accessories.
4. 1.50 kW Fan Motor Heat (kW) = 1.20 x Fan kW + .06. 2.24 kW Fan Motor Heat (kW) = 1.140 x kW - .110.
5. Factory supplied motors, in commercial equipment, are definite purpose motors, specifically designed and tested to operate reliably and continuously at all cataloged conditions. Using the full horsepower range of our fan motors as shown in our tabular data will not result in nuisance tripping or premature motor failure. Our product's warranty will not be affected.

(a) BAYLSDR005A  
 (b) BAYHSDR013A (or 2.24 Nom kW Oversized Motor and Drive)  
 (c) BAYHSMTO97A



## Evaporator Fan Performance

**Table 50. Belt drive evaporator fan performance—8½ tons—TSC102ED—downflow airflow (IP)**

External Static Pressure (Inches of Water)																						
		.10		.20		.30		.40		.50		.60		.70		.80		.90		1.00		
cfm	rpm	bhp	rpm	bhp	rpm	bhp	rpm	bhp	rpm	bhp	rpm	bhp	rpm	bhp	rpm	bhp	rpm	bhp	rpm	bhp	rpm	bhp
<b>2-hp Std Motor &amp; Field Supplied Low Static Drive<sup>(a)</sup></b>																						
2720	—	—	—	—	—	—	—	—	—	615	0.67	652	0.76	688	0.85	723	0.95	757	1.05	790	1.15	
3060	—	—	—	—	—	—	609	0.73	644	0.82	681	0.93	714	1.03	747	1.13	779	1.23	810	1.34		
3400	—	—	—	—	613	0.83	647	0.93	678	1.01	710	1.11	744	1.23	774	1.33	804	1.45	833	1.56		
3740	—	—	621	0.95	655	1.05	686	1.15	717	1.25	744	1.34	772	1.44	805	1.57	834	1.70	861	1.82		
4080	629	1.07	664	1.18	697	1.30	727	1.41	755	1.52	784	1.63	808	1.72	833	1.83	862	1.97	892	2.11		
<b>2-hp Std Motor &amp; Drive</b>																						

Continued

External Static Pressure (Inches of Water)																						
		1.10		1.20		1.30		1.40		1.50		1.60		1.70		1.80		1.90		2.00		
cfm	rpm	bhp	rpm	bhp	rpm	bhp	rpm	bhp	rpm	bhp	rpm	bhp	rpm	bhp	rpm	bhp	rpm	bhp	rpm	bhp	rpm	bhp
<b>2-hp Std. Motor &amp; Drive</b>											<b>2-hp Std Motor &amp; Field Supplied High Static Drive or 3-hp Oversized Motor &amp; Drive<sup>(b)</sup></b>											
2720	819	1.26	848	1.36	876	1.47	901	1.57	927	1.69	952	1.80	976	1.90	1000	2.02	1023	2.13	1044	2.24		
3060	840	1.45	870	1.56	897	1.68	924	1.80	950	1.92	974	2.04	998	2.16	1021	2.28	1044	2.41	1066	2.53		
3400	862	1.68	891	1.80	918	1.92	944	2.04	972	2.17	996	2.30	1019	2.42	1042	2.56	1066	2.69	1087	2.83		
3740	887	1.94	915	2.07	940	2.19	966	2.32	991	2.45	1016	2.58	1041	2.72	1065	2.86	1088	3.01	1110	3.15		
4080	916	2.24	941	2.37	966	2.51	990	2.64	1015	2.78	1039	2.92	1061	3.06	1084	3.20	1108	3.35	1131	3.50		
<b>3-hp Oversized Motor &amp; Drive<sup>(c)</sup></b>																						

**Notes:**

1. For Standard Evaporator Fan Speed (RPM), reference [Table 97, p. 117](#).
2. Data includes pressure drop due to standard filters and wet coils.
3. Refer to [Table 108, p. 119](#) to determine additional static pressure drop due to other options/accessories.
4. 2-hp Fan Motor Heat (MBh) = 3.100 x Fan bhp + .200. 3-hp Fan Motor Heat (MBh) = 2.900 x Fan bhp - .3800.
5. Factory supplied motors, in commercial equipment, are definite purpose motors, specifically designed and tested to operate reliably and continuously at all cataloged conditions. Using the full horsepower range of our fan motors as shown in our tabular data will not result in nuisance tripping or premature motor failure. Our product's warranty will not be affected.

(a) BAYLSDR005A  
 (b) BAYHSDR013A (or 3-hp Oversized Motor and Drive)  
 (c) BAYHSMT097A

## Evaporator Fan Performance

**Table 51. Belt drive evaporator fan performance—8½ tons—TSC102ED—horizontal airflow (SI)**

																						External Static Pressure (Pascals)									
		25		50		75		100		125		150		175		200		225		250											
m <sup>3</sup> /h	rpm	kW	rpm	kW	rpm	kW	rpm	kW	rpm	kW	rpm	kW	rpm	kW	rpm	kW	rpm	kW	rpm	kW											
<b>1.50 Nom kW Std Motor &amp; Field Supplied Low Static Drive<sup>(a)</sup></b>																															
4620	—	—	—	—	607	0.46	647	0.53	703	0.63	759	0.76	796	0.85	828	0.93	858	1.01	887	1.09											
5200	—	—	615	0.53	656	0.61	690	0.67	725	0.75	771	0.85	828	1.00	868	1.12	900	1.22	928	1.31											
5780	626	0.62	666	0.70	703	0.78	738	0.86	768	0.93	801	1.01	838	1.11	887	1.26	937	1.44	968	1.55											
6350	680	0.80	718	0.89	752	0.98	785	1.07	816	1.15	844	1.23	872	1.32	904	1.42	944	1.56	990	1.74											
6930	735	1.02	770	1.12	803	1.21	834	1.31	864	1.41	892	1.50	917	1.59	943	1.68	970	1.78	1003	1.91											
<b>1.50 Nom kW Std Motor &amp; Drive</b>																															

Continued

																						External Static Pressure (Pascals)									
		275		300		325		350		375		400		425		450		475		500											
m <sup>3</sup> /h	rpm	kW	rpm	kW	rpm	kW	rpm	kW	rpm	kW	rpm	kW	rpm	kW	rpm	kW	rpm	kW	rpm	kW											
<b>1.50 Nom kW Std Motor &amp; Drive</b>											<b>1.50 Nom kW Std Motor &amp; Field Supplied High Static Drive or 2.24 Nom kW Oversized Motor &amp; Drive<sup>(b)</sup></b>																				
4620	913	1.17	939	1.25	964	1.33	988	1.41	1011	1.49	1034	1.58	1056	1.66	1078	1.74	1099	1.82	1118	1.90											
5200	955	1.41	981	1.50	1005	1.59	1029	1.68	1052	1.77	1075	1.86	1097	1.95	1117	2.04	1137	2.13	1158	2.22											
5780	997	1.66	1022	1.76	1048	1.87	1071	1.97	1094	2.07	1117	2.18	1138	2.28	1158	2.37	1179	2.47	1199	2.57											
6350	1035	1.94	1062	2.06	1088	2.17	1113	2.29	1136	2.40	1158	2.52	1179	2.63	1201	2.75	1220	2.85	1240	2.96											
6930	1044	2.09	1085	2.28	1126	2.50	1152	2.63	1176	2.76	1200	2.89	1222	3.01	1242	3.13	1263	3.26	—	—											
<b>2.24 Nom kW Oversized Motor &amp; Drive<sup>(c)</sup></b>																															

**Notes:**

1. For Standard Evaporator Fan Speed (RPM), reference [Table 97, p. 117](#).
2. Data includes pressure drop due to standard filters and wet coils.
3. Refer to [Table 107, p. 119](#) to determine additional static pressure drop due to other options/accessories.
4. 1.50 kW Fan Motor Heat (kW) = 1.20 x Fan kW + .06. 2.24 kW Fan Motor Heat (kW) = 1.140 x kW - .110.
5. Factory supplied motors, in commercial equipment, are definite purpose motors, specifically designed and tested to operate reliably and continuously at all cataloged conditions. Using the full horsepower range of our fan motors as shown in our tabular data will not result in nuisance tripping or premature motor failure. Our product's warranty will not be affected.

(a) BAYLSDR005A  
 (b) BAYHSDR013A (or 2.24 Nom kW Oversized Motor and Drive)  
 (c) BAYHSMTO97A



## Evaporator Fan Performance

**Table 52. Belt drive evaporator fan performance—8½ tons—TSC102ED—horizontal airflow (IP)**

External Static Pressure (Inches of Water)																					
		.10		.20		.30		.40		.50		.60		.70		.80		.90		1.00	
cfm	rpm	bhp	rpm	bhp	rpm	bhp	rpm	bhp	rpm	bhp	rpm	bhp	rpm	bhp	rpm	bhp	rpm	bhp	rpm	bhp	
2-hp Std Motor & Field Supplied Low Static Drive <sup>(a)</sup>											2-hp Std Motor & Drive										
2720	—	—	—	—	607	0.62	647	0.71	703	0.85	759	1.02	796	1.13	828	1.24	858	1.36	887	1.47	
3060	—	—	615	0.72	656	0.82	690	0.90	725	1.00	771	1.14	828	1.35	868	1.50	900	1.63	928	1.76	
3400	626	0.83	666	0.93	703	1.04	738	1.15	768	1.24	801	1.35	838	1.49	887	1.69	937	1.93	968	2.08	
3740	680	1.07	718	1.19	752	1.31	785	1.43	816	1.55	844	1.65	872	1.76	904	1.90	944	2.09	990	2.33	
4080	735	1.37	770	1.50	803	1.63	834	1.75	864	1.89	892	2.01	917	2.13	943	2.25	970	2.39	1003	2.56	

Continued

External Static Pressure (Inches of Water)																					
		1.10		1.20		1.30		1.40		1.50		1.60		1.70		1.80		1.90		2.00	
cfm	rpm	bhp	rpm	bhp	rpm	bhp	rpm	bhp	rpm	bhp	rpm	bhp	rpm	bhp	rpm	bhp	rpm	bhp	rpm	bhp	
2-hp Std. Motor & Drive								2-hp Std Motor & Field Supplied High Static Drive or 3-hp Oversized Motor & Drive <sup>(b)</sup>													
2720	913	1.57	939	1.68	964	1.79	988	1.90	1011	2.00	1034	2.11	1056	2.22	1078	2.33	1099	2.44	1118	2.55	
3060	955	1.89	981	2.01	1005	2.13	1029	2.25	1052	2.37	1075	2.49	1097	2.61	1117	2.73	1137	2.85	1158	2.98	
3400	997	2.22	1022	2.36	1048	2.50	1071	2.64	1094	2.78	1117	2.92	1138	3.05	1158	3.18	1179	3.31	1199	3.45	
3740	1035	2.59	1062	2.76	1088	2.91	1113	3.07	1136	3.22	1158	3.38	1179	3.53	1201	3.68	1220	3.82	1240	3.97	
4080	1044	2.80	1085	3.06	1126	3.35	1152	3.53	1176	3.70	1200	3.87	1222	4.04	1242	4.20	1263	4.37	—	—	
<b>3-hp Oversized Motor &amp; Drive<sup>(c)</sup></b>																					

**Notes:**

1. For Standard Evaporator Fan Speed (RPM), reference [Table 97, p. 117](#).
2. Data includes pressure drop due to standard filters and wet coils.
3. Refer to [Table 108, p. 119](#) to determine additional static pressure drop due to other options/accessories.
4. 2-hp Fan Motor Heat (MBh) = 3.100 x Fan bhp + 0.200. 3-hp Fan Motor Heat (MBh) = 2.900 x Fan bhp - .3800.
5. Factory supplied motors, in commercial equipment, are definite purpose motors, specifically designed and tested to operate reliably and continuously at all cataloged conditions. Using the full horsepower range of our fan motors as shown in our tabular data will not result in nuisance tripping or premature motor failure. Our product's warranty will not be affected.

(a) BAYLSDR005A  
 (b) BAYHSDR013A (or 3-hp Oversized Motor and Drive)  
 (c) BAYHSMT097A

## Evaporator Fan Performance

**Table 53. Belt drive evaporator fan performance—8½ tons—YSC102ED—low gas heat—downflow airflow (SI)**

																						External Static Pressure (Pascals)									
		25		50		75		100		125		150		175		200		225		250											
m <sup>3</sup> /h	rpm	rpm	kW	rpm	kW	rpm	kW	rpm	kW	rpm	kW	rpm	kW	rpm	kW	rpm	kW	rpm	kW	rpm	kW										
																						<b>1.50 Nom kW Std Motor &amp; Field Supplied Low Static Drive<sup>(a)</sup></b>									
4620	—	—	—	—	—	—	—	611	0.49	652	0.56	686	0.62	720	0.69	752	0.76	781	0.82	809	0.89										
5200	—	—	—	—	613	0.55	652	0.62	685	0.69	721	0.77	754	0.84	784	0.91	814	0.99	842	1.07											
5780	—	—	618	0.62	656	0.70	692	0.78	726	0.86	757	0.93	788	1.02	820	1.10	848	1.18	874	1.26											
6350	623	0.70	663	0.79	700	0.88	734	0.97	766	1.05	797	1.14	825	1.22	853	1.31	883	1.41	910	1.50											
6930	672	0.88	710	0.99	745	1.09	778	1.19	808	1.28	837	1.37	866	1.47	892	1.55	916	1.64	943	1.75											
																						<b>1.50 Nom kW Std Motor &amp; Drive</b>									

Continued

																						External Static Pressure (Pascals)																			
		275		300		325		350		375		400		425		450		475		500																					
m <sup>3</sup> /h	rpm	rpm	kW	rpm	kW	rpm	kW	rpm	kW	rpm	kW	rpm	kW	rpm	kW	rpm	kW	rpm	kW	rpm	kW																				
																						<b>1.50 Nom kW Std Motor &amp; Drive</b>										<b>1.50 Nom kW Std Motor &amp; Field Supplied High Static Drive or 2.24 Nom kW Oversized Motor &amp; Drive<sup>(b)</sup></b>									
4620	837	0.96	863	1.03	889	1.10	914	1.18	938	1.25	962	1.32	984	1.39	1006	1.47	1027	1.54	1049	1.62																					
5200	869	1.15	895	1.22	919	1.30	944	1.38	966	1.45	990	1.54	1013	1.62	1035	1.70	1056	1.78	1076	1.86																					
5780	901	1.35	927	1.44	952	1.52	975	1.61	998	1.69	<sup>(c)</sup> 1021	1.78	1042	1.87	1063	1.95	1084	2.04	1105	2.13																					
6350	936	1.59	960	1.68	984	1.77	<sup>(d)</sup> 1008	1.86	1031	1.96	1053	2.05	1074	2.14	1095	2.24	1114	2.33	1136	2.43																					
6930	970	1.85	996	1.96	1018	2.05	1041	2.15	1063	2.25	1085	2.35	1107	2.45	1128	2.56	1148	2.66	1167	2.76																					
																						<b>2.24 Nom kW Oversized Motor &amp; Drive<sup>(e)</sup></b>																			

**Notes:**

1. For Standard Evaporator Fan Speed (RPM), reference [Table 97, p. 117](#).
2. Data includes pressure drop due to standard filters and wet coils.
3. Refer to [Table 107, p. 119](#) to determine additional static pressure drop due to other options/accessories.
4. 1.50 kW Fan Motor Heat (kW) = 1.20 x Fan kW + 0.06. 2.24 kW Fan Motor Heat (kW) = 1.140 x kW - .110.
5. Factory supplied motors, in commercial equipment, are definite purpose motors, specifically designed and tested to operate reliably and continuously at all cataloged conditions. Using the full horsepower range of our fan motors as shown in our tabular data will not result in nuisance tripping or premature motor failure. Our product's warranty will not be affected.

(a) BAYLSDR005A  
 (b) BAYHSDR013A (or 2.24 Nom kW Oversized Motor and Drive)  
 (c) BAYHSDR013A (or 2.24 Nom kW Oversized Motor and Drive)  
 (d) BAYHSDR013A (or 2.24 Nom kW Oversized Motor and Drive)  
 (e) BAYHSMT097A



## Evaporator Fan Performance

**Table 54. Belt drive evaporator fan performance—8½ tons—YSC102ED—low gas heat—downflow airflow (IP)**

External Static Pressure (Inches of Water)																					
		.10		.20		.30		.40		.50		.60		.70		.80		.90		1.00	
cfm	rpm	bhp	rpm	bhp	rpm	bhp	rpm	bhp	rpm	bhp	rpm	bhp	rpm	bhp	rpm	bhp	rpm	bhp	rpm	bhp	
<b>2-hp Std Motor &amp; Field Supplied Low Static Drive<sup>(a)</sup></b>																					
2720	—	—	—	—	—	—	611	0.65	652	0.75	686	0.83	720	0.92	752	1.02	781	1.11	809	1.20	
3060	—	—	—	—	613	0.74	652	0.83	685	0.92	721	1.03	754	1.13	784	1.23	814	1.33	842	1.43	
3400	—	—	618	0.84	656	0.94	692	1.05	726	1.15	757	1.25	788	1.36	820	1.48	848	1.59	874	1.69	
3740	623	0.93	663	1.06	700	1.18	734	1.30	766	1.41	797	1.53	825	1.63	853	1.75	883	1.88	910	2.01	
4080	672	1.19	710	1.32	745	1.46	778	1.59	808	1.72	837	1.84	866	1.96	892	2.08	916	2.20	943	2.34	
<b>2-hp Std Motor &amp; Drive</b>																					

Continued

External Static Pressure (Inches of Water)																					
		1.10		1.20		1.30		1.40		1.50		1.60		1.70		1.80		1.90		2.00	
cfm	rpm	bhp	rpm	bhp	rpm	bhp	rpm	bhp	rpm	bhp	rpm	bhp	rpm	bhp	rpm	bhp	rpm	bhp	rpm	bhp	
<b>2-hp Std. Motor &amp; Drive</b>																					
<b>2-hp Std Motor &amp; Field Supplied High Static Drive or 3-hp Oversized Motor &amp; Drive<sup>(b)</sup></b>																					
2720	837	1.29	863	1.38	889	1.48	914	1.58	938	1.67	962	1.77	984	1.87	1006	1.97	1027	2.07	1049	2.17	
3060	869	1.54	895	1.64	919	1.74	944	1.85	966	1.95	990	2.06	1013	2.17	1035	2.28	1056	2.39	1076	2.49	
3400	901	1.81	927	1.92	952	2.04	975	2.15	998	2.27	<sup>(c)</sup> 1021	2.39	1042	2.50	1063	2.61	1084	2.74	1105	2.85	
3740	936	2.13	960	2.25	984	2.37	<sup>(d)</sup> 1008	2.49	1031	2.62	1053	2.75	1074	2.87	1095	3.00	1114	3.12	1136	3.26	
4080	970	2.49	996	2.62	1018	2.75	1041	2.88	1063	3.01	1085	3.15	1107	3.29	1128	3.43	1148	3.57	1167	3.70	
<b>3-hp Oversized Motor &amp; Drive<sup>(e)</sup></b>																					

**Notes:**

1. For Standard Evaporator Fan Speed (RPM), reference [Table 97, p. 117](#).
2. Data includes pressure drop due to standard filters and wet coils.
3. Refer to [Table 108, p. 119](#) to determine additional static pressure drop due to other options/accessories.
4. 2-hp Fan Motor Heat (MBh) = 3.100 x Fan bhp + .200. 3-hp Fan Motor Heat (MBh) = 2.900 x Fan bhp - .3800.
5. Factory supplied motors, in commercial equipment, are definite purpose motors, specifically designed and tested to operate reliably and continuously at all cataloged conditions. Using the full horsepower range of our fan motors as shown in our tabular data will not result in nuisance tripping or premature motor failure. Our product's warranty will not be affected.

- (a) BAYLSDR005A  
 (b) BAYHSDR013A (or 3-hp Oversized Motor and Drive)  
 (c) BAYHSDR013A (or 3-hp Oversized Motor and Drive)  
 (d) BAYHSDR013A (or 3-hp Oversized Motor and Drive)  
 (e) BAYHSMT097A

## Evaporator Fan Performance

**Table 55. Belt drive evaporator fan performance—8½ tons—YSC102ED—high gas heat—downflow airflow (SI)**

m <sup>3</sup> /h		External Static Pressure (Pascals)																			
		25		50		75		100		125		150		175		200		225		250	
rpm	kW	rpm	kW	rpm	kW	rpm	kW	rpm	kW	rpm	kW	rpm	kW	rpm	kW	rpm	kW	rpm	kW	rpm	kW
<b>1.50 Nom kW Std Motor &amp; Field Supplied Low Static Drive<sup>(a)</sup></b>																					
4620	—	—	—	—	—	—	—	638	0.53	678	0.59	714	0.66	747	0.73	779	0.80	808	0.87	836	0.94
5200	—	—	—	—	634	0.58	672	0.65	715	0.74	751	0.82	785	0.90	815	0.98	844	1.06	872	1.13	
5780	604	0.59	647	0.68	685	0.75	713	0.81	750	0.89	789	1.00	821	1.09	853	1.18	882	1.27	909	1.35	
6350	656	0.77	696	0.86	732	0.95	763	1.03	788	1.08	823	1.18	860	1.31	891	1.41	920	1.50	947	1.60	
6930	708	0.98	745	1.08	780	1.18	812	1.27	838	1.35	861	1.41	893	1.52	929	1.66	957	1.77	984	1.88	
<b>1.50 Nom kW Std Motor &amp; Drive</b>																					

Continued

m <sup>3</sup> /h		External Static Pressure (Pascals)																			
		275		300		325		350		375		400		425		450		475		500	
rpm	kW	rpm	kW	rpm	kW	rpm	kW	rpm	kW	rpm	kW	rpm	kW	rpm	kW	rpm	kW	rpm	kW	rpm	kW
<b>1.50 Nom kW Std Motor &amp; Drive</b>						<b>1.50 Nom kW Std Motor &amp; Field Supplied High Static Drive or 2.24 Nom kW Oversized Motor &amp; Drive<sup>(b)</sup></b>															
4620	861	1.01	888	1.08	914	1.15	939	1.22	962	1.29	986	1.37	1008	1.44	1031	1.51	1053	1.59	1072	1.66	
5200	899	1.21	924	1.29	947	1.36	971	1.44	995	1.52	1018	1.60	1040	1.68	1062	1.77	1084	1.85	1104	1.93	
5780	935	1.44	960	1.52	985	1.61	<sup>(c)</sup> 1009	1.69	1031	1.78	1053	1.87	1074	1.95	1095	2.04	1116	2.13	1137	2.22	
6350	973	1.70	997	1.79	1022	1.89	1045	1.98	1067	2.07	1089	2.16	1111	2.26	1131	2.35	1150	2.45	1170	2.54	
6930	1011	1.98	1035	2.08	1059	2.19	1083	2.30	1104	2.40	1126	2.50	1146	2.60	1168	2.71	1188	2.81	1207	2.91	
<b>2.24 Nom kW Oversized Motor &amp; Drive<sup>(d)</sup></b>																					

**Notes:**

1. For Standard Evaporator Fan Speed (RPM), reference [Table 97, p. 117](#).
2. Data includes pressure drop due to standard filters and wet coils.
3. Refer to [Table 107, p. 119](#) to determine additional static pressure drop due to other options/accessories.
4. 1.50 kW Fan Motor Heat (kW) = 1.20 x Fan kW + 0.06. 2.24 kW Fan Motor Heat (kW) = 1.140 x kW - .110.
5. Factory supplied motors, in commercial equipment, are definite purpose motors, specifically designed and tested to operate reliably and continuously at all cataloged conditions. Using the full horsepower range of our fan motors as shown in our tabular data will not result in nuisance tripping or premature motor failure. Our product's warranty will not be affected.

(a) BAYLSDR005A  
 (b) BAYHSDR013A (or 2.24 Nom kW Oversized Motor and Drive)  
 (c) BAYHSDR013A (or 2.24 Nom kW Oversized Motor and Drive)  
 (d) BAYHSMT097A



## Evaporator Fan Performance

**Table 56. Belt drive evaporator fan performance—8½ tons—YSC102ED—high gas heat—downflow airflow (IP)**

External Static Pressure (Inches of Water)																					
		.10		.20		.30		.40		.50		.60		.70		.80		.90		1.00	
cfm	rpm	bhp	rpm	bhp	rpm	bhp	rpm	bhp	rpm	bhp	rpm	bhp	rpm	bhp	rpm	bhp	rpm	bhp	rpm	bhp	
<b>2-hp Std Motor &amp; Field Supplied Low Static Drive<sup>(a)</sup></b>																					
2720	—	—	—	—	—	—	638	0.70	678	0.80	714	0.89	747	0.98	779	1.08	808	1.16	836	1.26	
3060	—	—	—	—	634	0.77	672	0.87	715	1.00	751	1.10	785	1.21	815	1.31	844	1.42	872	1.52	
3400	604	0.79	647	0.91	685	1.01	713	1.08	750	1.20	789	1.35	821	1.46	853	1.58	882	1.70	909	1.81	
3740	656	1.03	696	1.15	732	1.27	763	1.37	788	1.45	823	1.59	860	1.76	891	1.89	920	2.02	947	2.15	
4080	708	1.31	745	1.45	780	1.58	812	1.71	838	1.80	861	1.89	893	2.03	929	2.23	957	2.38	984	2.52	
<b>2-hp Std Motor &amp; Drive</b>																					

Continued

External Static Pressure (Inches of Water)																					
		1.10		1.20		1.30		1.40		1.50		1.60		1.70		1.80		1.90		2.00	
cfm	rpm	bhp	rpm	bhp	rpm	bhp	rpm	bhp	rpm	bhp	rpm	bhp	rpm	bhp	rpm	bhp	rpm	bhp	rpm	bhp	
<b>2-hp Std. Motor &amp; Drive</b>						<b>2-hp Std Motor &amp; Field Supplied High Static Drive or 3-hp Oversized Motor &amp; Drive<sup>(b)</sup></b>															
2720	861	1.35	888	1.45	914	1.54	939	1.64	962	1.73	986	1.83	1008	1.93	1031	2.03	1053	2.13	1072	2.22	
3060	899	1.62	924	1.72	947	1.82	971	1.93	995	2.04	1018	2.15	1040	2.25	1062	2.37	1084	2.48	1104	2.58	
3400	935	1.93	960	2.04	985	2.16	1009	2.27	1031	2.38	1053	2.50	1074	2.62	1095	2.74	1116	2.86	1137	2.98	
3740	973	2.27	997	2.40	1022	2.53	1045	2.65	1067	2.78	1089	2.90	1111	3.03	1131	3.15	1150	3.28	1170	3.41	
4080	1011	2.66	1035	2.79	1059	2.94	1083	3.08	1104	3.22	1126	3.36	1146	3.49	1168	3.63	1188	3.77	1207	3.90	
<b>3-hp Oversized Motor &amp; Drive<sup>(c)</sup></b>																					

**Notes:**

1. For Standard Evaporator Fan Speed (RPM), reference [Table 97, p. 117](#).
2. Data includes pressure drop due to standard filters and wet coils.
3. Refer to [Table 108, p. 119](#) to determine additional static pressure drop due to other options/accessories.
4. 2-hp Fan Motor Heat (MBh) = 3.100 x Fan bhp + .200. 3-hp Fan Motor Heat (MBh) = 2.900 x Fan bhp + .3800.
5. Factory supplied motors, in commercial equipment, are definite purpose motors, specifically designed and tested to operate reliably and continuously at all cataloged conditions. Using the full horsepower range of our fan motors as shown in our tabular data will not result in nuisance tripping or premature motor failure. Our product's warranty will not be affected.

(a) BAYLSDR005A  
 (b) BAYHSDR013A (or 3-hp Oversized Motor and Drive)  
 (c) BAYHSMT097A



## Evaporator Fan Performance

**Table 57. Belt drive evaporator fan performance—8½ tons—YSC102ED—low gas heat—horizontal airflow (SI)**

																						External Static Pressure (Pascals)									
		25		50		75		100		125		150		175		200		225		250											
m <sup>3</sup> /h	rpm	kW	rpm	kW	rpm	kW	rpm	kW	rpm	kW	rpm	kW	rpm	kW	rpm	kW	rpm	kW	rpm	kW											
											<b>1.50 Nom kW Std Motor &amp; Field Supplied Low Static Drive<sup>(a)</sup></b>																				
											<b>1.50 Nom kW Std Motor &amp; Drive</b>																				
4620	—	—	616	0.48	662	0.55	698	0.61	734	0.69	769	0.76	801	0.82	832	0.89	863	0.97	892	1.05											
5200	632	0.55	671	0.63	713	0.72	751	0.80	784	0.87	816	0.95	848	1.03	877	1.11	905	1.19	934	1.27											
5780	693	0.74	729	0.83	766	0.92	803	1.01	836	1.10	866	1.18	894	1.26	924	1.36	951	1.45	978	1.53											
6350	755	0.97	788	1.06	821	1.16	855	1.26	888	1.36	919	1.46	945	1.54	971	1.63	998	1.74	1024	1.84											
6930	817	1.24	849	1.34	878	1.44	909	1.55	940	1.66	971	1.77	999	1.88	1023	1.97	1048	2.07	1071	2.17											
											<b>2.24 Nom kW Oversized Motor &amp; Drive<sup>(b)</sup></b>																				

Continued

																						External Static Pressure (Pascals)									
		275		300		325		350		375		400		425		450		475		500											
m <sup>3</sup> /h	rpm	kW	rpm	kW	rpm	kW	rpm	kW	rpm	kW	rpm	kW	rpm	kW	rpm	kW	rpm	kW	rpm	kW											
							<b>1.50 Nom kW Std Motor &amp; Drive</b>																								
							<b>1.50 Nom kW Std Motor &amp; Field Supplied High Static Drive or 2.24 Nom kW Oversized Motor &amp; Drive<sup>(c)</sup></b>																								
4620	920	1.12	946	1.20	972	1.28	997	1.36	1021	1.44	1044	1.51	1067	1.59	1089	1.67	1110	1.75	1132	1.83											
5200	960	1.35	987	1.43	1012	1.52	1037	1.61	1061	1.69	1083	1.78	1105	1.87	1128	1.96	1149	2.04	1170	2.13											
5780	1003	1.62	1028	1.70	1054	1.80	1077	1.89	1101	1.98	1124	2.08	1146	2.18	1168	2.28	1189	2.37	1208	2.46											
6350	1049	1.93	1073	2.03	1097	2.12	1118	2.21	1142	2.31	1165	2.42	1186	2.52	1208	2.62	1229	2.73	1249	2.83											
6930	1096	2.28	1119	2.40	1143	2.50	1164	2.60	1186	2.71	1207	2.81	1228	2.91	1249	3.02	1269	3.13	1290	3.24											
											<b>2.24 Nom kW Oversized Motor &amp; Drive<sup>(d)</sup></b>																				

**Notes:**

1. For Standard Evaporator Fan Speed (RPM), reference [Table 97, p. 117](#).
2. Data includes pressure drop due to standard filters and wet coils.
3. Refer to [Table 107, p. 119](#) to determine additional static pressure drop due to other options/accessories.
4. 1.50 kW Fan Motor Heat (kW) = 1.20 x Fan kW + 0.06. 2.24 kW Fan Motor Heat (kW) = 1.140 x kW - .110.
5. Factory supplied motors, in commercial equipment, are definite purpose motors, specifically designed and tested to operate reliably and continuously at all cataloged conditions. Using the full horsepower range of our fan motors as shown in our tabular data will not result in nuisance tripping or premature motor failure. Our product's warranty will not be affected.

(a) BAYLSDR005A  
 (b) BAYHSMT097A  
 (c) BAYHSDR013A (or 2.24 Nom kW Oversized Motor and Drive)  
 (d) BAYHSMT097A



## Evaporator Fan Performance

**Table 58. Belt drive evaporator fan performance—8½ tons—YSC102ED—low gas heat—horizontal airflow (IP)**

External Static Pressure (Inches of Water)																						
		.10		.20		.30		.40		.50		.60		.70		.80		.90		1.00		
cfm	rpm	bhp	rpm	bhp	rpm	bhp	rpm	bhp	rpm	bhp	rpm	bhp	rpm	bhp	rpm	bhp	rpm	bhp	rpm	bhp	rpm	bhp
2-hp Std Motor & Field Supplied Low Static Drive <sup>(a)</sup>											2-hp Std Motor & Drive											
2720	—	—	616	0.64	662	0.74	698	0.82	734	0.92	769	1.01	801	1.11	832	1.20	863	1.30	892	1.40		
3060	632	0.74	671	0.85	713	0.96	751	1.07	784	1.17	816	1.27	848	1.38	877	1.49	905	1.59	934	1.70		
3400	693	0.99	729	1.11	766	1.23	803	1.36	836	1.47	866	1.58	894	1.69	924	1.82	951	1.94	978	2.05		
3740	755	1.30	788	1.42	821	1.55	855	1.69	888	1.82	919	1.95	945	2.07	971	2.19	998	2.33	1024	2.46		
4080	817	1.66	849	1.79	878	1.93	909	2.08	940	2.23	971	2.38	999	2.52	1023	2.65	1048	2.78	1071	2.92		
											3-hp Oversized Motor & Drive <sup>(b)</sup>											

Continued

External Static Pressure (Inches of Water)																						
		1.10		1.20		1.30		1.40		1.50		1.60		1.70		1.80		1.90		2.00		
cfm	rpm	bhp	rpm	bhp	rpm	bhp	rpm	bhp	rpm	bhp	rpm	bhp	rpm	bhp	rpm	bhp	rpm	bhp	rpm	bhp	rpm	bhp
2-hp Std. Motor & Drive								2-hp Std Motor & Field Supplied High Static Drive or 3-hp Oversized Motor & Drive <sup>(c)</sup>														
2720	920	1.51	946	1.61	972	1.71	997	1.82	1021	1.92	1044	2.03	1067	2.14	1089	2.24	1110	2.35	1132	2.46		
3060	960	1.81	987	1.92	1012	2.04	1037	2.15	1061	2.27	1083	2.39	1105	2.50	1128	2.63	1149	2.74	1170	2.86		
3400	1003	2.17	1028	2.28	1054	2.41	1077	2.53	1101	2.66	1124	2.79	1146	2.92	1168	3.05	1189	3.18	1208	3.30		
3740	1049	2.59	1073	2.72	1097	2.85	1118	2.97	1142	3.10	1165	3.24	1186	3.37	1208	3.51	1229	3.66	1249	3.80		
4080	1096	3.06	1119	3.21	1143	3.36	1164	3.49	1186	3.63	1207	3.77	1228	3.90	1249	4.05	1269	4.20	1290	4.35		
											3-hp Oversized Motor & Drive <sup>(d)</sup>											

**Notes:**

1. For Standard Evaporator Fan Speed (RPM), reference [Table 97, p. 117](#).
2. Data includes pressure drop due to standard filters and wet coils.
3. Refer to [Table 108, p. 119](#) to determine additional static pressure drop due to other options/accessories.
4. 2-hp Fan Motor Heat (MBh) = 3.100 x Fan bhp + 0.200. 3-hp Fan Motor Heat (MBh) = 2.900 x Fan bhp - .3800.
5. Factory supplied motors, in commercial equipment, are definite purpose motors, specifically designed and tested to operate reliably and continuously at all cataloged conditions. Using the full horsepower range of our fan motors as shown in our tabular data will not result in nuisance tripping or premature motor failure. Our product's warranty will not be affected.

(a) BAYLSDR005A  
 (b) BAYHSMT097A  
 (c) BAYHSDR013A (or 3-hp Oversized Motor and Drive)  
 (d) BAYHSMT097A

## Evaporator Fan Performance

**Table 59. Belt drive evaporator fan performance—8½ tons—YSC102ED—high gas heat—horizontal airflow (SI)**

																						External Static Pressure (Pascals)									
		25		50		75		100		125		150		175		200		225		250											
m <sup>3</sup> /h	rpm	kW	rpm	kW	rpm	kW	rpm	kW	rpm	kW	rpm	kW	rpm	kW	rpm	kW	rpm	kW	rpm	kW											
											<b>1.50 Nom kW Std Motor &amp; Field Supplied Low Static Drive<sup>(a)</sup></b>																				
											<b>1.50 Nom kW Std Motor &amp; Drive</b>																				
4620	—	—	644	0.52	690	0.61	729	0.69	764	0.76	797	0.84	828	0.91	856	0.98	885	1.06	911	1.13											
5200	670	0.63	702	0.69	744	0.79	784	0.88	818	0.97	850	1.06	879	1.14	908	1.22	934	1.31	961	1.39											
5780	738	0.85	766	0.91	800	1.01	838	1.12	873	1.22	904	1.32	933	1.41	960	1.51	986	1.60	<sup>(b)</sup> 1011	1.69											
6350	806	1.12	831	1.19	859	1.27	893	1.39	927	1.50	959	1.62	988	1.73	<sup>(c)</sup> 1014	1.83	1039	1.94	1064	2.04											
6930	874	1.43	898	1.51	921	1.59	950	1.70	982	1.83	1013	1.96	1042	2.08	1069	2.20	1094	2.32	1118	2.44											
											<b>2.24 Nom kW Oversized Motor &amp; Drive<sup>(d)</sup></b>																				

Continued

																						External Static Pressure (Pascals)									
		275		300		325		350		375		400		425		450		475		500											
m <sup>3</sup> /h	rpm	kW	rpm	kW	rpm	kW	rpm	kW	rpm	kW	rpm	kW	rpm	kW	rpm	kW	rpm	kW	rpm	kW											
								<b>1.50 Nom kW Std Motor &amp; Drive</b>																							
								<b>1.50 Nom kW Std Motor &amp; Field Supplied High Static Drive or 2.24 Nom kW Oversized Motor &amp; Drive<sup>(e)</sup></b>																							
4620	936	1.20	961	1.27	984	1.34	1008	1.41	1029	1.48	1052	1.55	1072	1.62	1093	1.69	1113	1.76	1132	1.83											
5200	985	1.47	1010	1.56	1033	1.63	1055	1.71	1077	1.79	1098	1.87	1119	1.95	1140	2.03	1158	2.11	1178	2.19											
5780	1036	1.78	1060	1.88	1082	1.97	1104	2.06	1126	2.15	1146	2.24	1167	2.33	1187	2.42	1206	2.50	1225	2.59											
6350	1087	2.14	1110	2.24	1132	2.34	1154	2.45	1176	2.55	1196	2.65	1216	2.75	1235	2.85	1254	2.94	1273	3.04											
6930	1141	2.55	1163	2.66	1184	2.77	1205	2.87	1226	2.99	1246	3.10	1266	3.21	1285	3.32	—	—	—	—											
											<b>2.24 Nom kW Oversized Motor &amp; Drive<sup>(f)</sup></b>																				

**Notes:**

1. For Standard Evaporator Fan Speed (RPM), reference [Table 97, p. 117](#).
2. Data includes pressure drop due to standard filters and wet coils.
3. Refer to [Table 107, p. 119](#) to determine additional static pressure drop due to other options/accessories.
4. 1.50 kW Fan Motor Heat (MBh) = 1.20 x Fan kW + 0.06. 2.24 kW Fan Motor Heat (kW) = 1.140 x kW - .110.
5. Factory supplied motors, in commercial equipment, are definite purpose motors, specifically designed and tested to operate reliably and continuously at all cataloged conditions. Using the full horsepower range of our fan motors as shown in our tabular data will not result in nuisance tripping or premature motor failure. Our product's warranty will not be affected.

(a) BAYLSDR005A  
 (b) BAYHSDR013A (or 2.24 Nom kW Oversized Motor and Drive)  
 (c) BAYHSDR013A (or 2.24 Nom kW Oversized Motor and Drive)  
 (d) BAYHSMT097A  
 (e) BAYHSDR013A (or 2.24 Nom kW Oversized Motor and Drive)  
 (f) BAYHSMT097A



## Evaporator Fan Performance

**Table 60. Belt drive evaporator fan performance—8½ tons—YSC102ED—high gas heat—horizontal airflow (IP)**

External Static Pressure (Inches of Water)																						
		.10		.20		.30		.40		.50		.60		.70		.80		.90		1.00		
cfm	rpm	bhp	rpm	bhp	rpm	bhp	rpm	bhp	rpm	bhp	rpm	bhp	rpm	bhp	rpm	bhp	rpm	bhp	rpm	bhp	rpm	bhp
2-hp Std Motor & Field Supplied Low Static Drive <sup>(a)</sup>											2-hp Std Motor & Drive											
2720	—	—	644	0.70	690	0.81	729	0.92	764	1.02	797	1.12	828	1.22	856	1.32	885	1.42	911	1.51		
3060	670	0.84	702	0.93	744	1.06	784	1.18	818	1.30	850	1.42	879	1.53	908	1.64	934	1.75	961	1.87		
3400	738	1.14	766	1.22	800	1.35	838	1.50	873	1.63	904	1.77	933	1.89	960	2.02	986	2.14	<sup>(b)</sup> 1011	2.27		
3740	806	1.50	831	1.59	859	1.70	893	1.86	927	2.02	959	2.17	988	2.31	<sup>(c)</sup> 1014	2.46	1039	2.60	1064	2.73		
4080	874	1.92	898	2.03	921	2.13	950	2.28	982	2.46	1013	2.63	1042	2.79	1069	2.95	1094	3.11	1118	3.26		
											3-hp Oversized Motor & Drive <sup>(d)</sup>											

Continued

External Static Pressure (Inches of Water)																						
		1.10		1.20		1.30		1.40		1.50		1.60		1.70		1.80		1.90		2.00		
cfm	rpm	bhp	rpm	bhp	rpm	bhp	rpm	bhp	rpm	bhp	rpm	bhp	rpm	bhp	rpm	bhp	rpm	bhp	rpm	bhp	rpm	bhp
2-hp Std. Motor & Drive								2-hp Std Motor & Field Supplied High Static Drive or 3-hp Oversized Motor & Drive <sup>(e)</sup>														
2720	936	1.61	961	1.70	984	1.80	1008	1.89	1029	1.98	1052	2.08	1072	2.17	1093	2.27	1113	2.36	1132	2.46		
3060	985	1.98	1010	2.09	1033	2.19	1055	2.30	1077	2.41	1098	2.51	1119	2.62	1140	2.73	1158	2.83	1178	2.94		
3400	1036	2.39	1060	2.52	1082	2.64	1104	2.76	1126	2.88	1146	3.00	1167	3.12	1187	3.24	1206	3.36	1225	3.48		
3740	1087	2.87	1110	3.00	1132	3.14	1154	3.28	1176	3.42	1196	3.55	1216	3.68	1235	3.82	1254	3.94	1273	4.08		
4080	1141	3.41	1163	3.56	1184	3.71	1205	3.85	1226	4.01	1246	4.15	1266	4.31	1285	4.45	—	—	—	—		
								3-hp Oversized Motor & Drive <sup>(f)</sup>														

**Notes:**

1. For Standard Evaporator Fan Speed (RPM), reference [Table 97, p. 117](#).
2. Data includes pressure drop due to standard filters and wet coils.
3. Refer to [Table 108, p. 119](#) to determine additional static pressure drop due to other options/accessories.
4. 2-hp Fan Motor Heat (MBh) = 3.100 x Fan bhp + 0.200. 3-hp Fan Motor Heat (MBh) = 2.900 x Fan bhp + .3800.
5. Factory supplied motors, in commercial equipment, are definite purpose motors, specifically designed and tested to operate reliably and continuously at all cataloged conditions. Using the full horsepower range of our fan motors as shown in our tabular data will not result in nuisance tripping or premature motor failure. Our product's warranty will not be affected.

- (a) BAYLSDR005A
- (b) BAYHSDR013A (or 3-hp Oversized Motor and Drive)
- (c) BAYHSDR013A (or 3-hp Oversized Motor and Drive)
- (d) BAYHSMT097A
- (e) BAYHSDR013A (or 3-hp Oversized Motor and Drive)
- (f) BAYHSMT097A

## Evaporator Fan Performance

**Table 61. Belt drive evaporator fan performance—10 tons—TSC120ED—downflow airflow (SI)**

																					External Static Pressure (Pascals)									
		25		50		75		100		125		150		175		200		225		250										
m <sup>3</sup> /h	rpm	rpm	kW	rpm	kW	rpm	kW	rpm	kW	rpm	kW	rpm	kW	rpm	kW	rpm	kW	rpm	kW	rpm	kW									
																					<b>2.24 Nom kW Std Motor &amp; Field Supplied High Static Drive<sup>(a)</sup></b>									
5440	—	—	—	—	—	—	—	—	—	703	0.74	741	0.83	776	0.92	808	1.00	841	1.10	871	1.18									
6120	—	—	—	—	—	—	—	703	0.82	743	0.92	780	1.02	814	1.12	846	1.22	877	1.33	906	1.42									
6800	—	—	—	—	704	0.90	746	1.02	784	1.13	819	1.24	853	1.36	885	1.47	915	1.58	943	1.69										
7480	—	—	704	0.97	749	1.11	789	1.24	826	1.37	861	1.50	894	1.63	925	1.75	953	1.87	983	2.00										
8160	705	1.05	752	1.21	794	1.36	833	1.50	869	1.65	903	1.79	934	1.93	965	2.06	994	2.20	1022	2.34										
																					<b>2.24 Nom kW Standard Motor &amp; Drive</b>									

**Continued**

																					External Static Pressure (Pascals)									
		275		300		325		350		375		400		425		450		475		500										
m <sup>3</sup> /h	rpm	rpm	kW	rpm	kW	rpm	kW	rpm	kW	rpm	kW	rpm	kW	rpm	kW	rpm	kW	rpm	kW	rpm	kW									
																					<b>2.24 Nom kW Standard Motor &amp; Drive</b>									
5440	894	1.25	916	1.31	944	1.40	972	1.49	999	1.59	1023	1.67	1047	1.77	1071	1.87	1095	1.98	1118	2.08										
6120	935	1.52	964	1.62	986	1.71	1007	1.78	1028	1.86	1051	1.95	1075	2.05	1100	2.15	1124	2.26	1146	2.36										
6800	971	1.80	998	1.91	1023	2.02	1050	2.14	1075	2.25	1096	2.34	1115	2.43	1133	2.51	1150	2.59	1172	2.69										
7480	1009	2.12	1036	2.24	1061	2.36	1086	2.48	1109	2.60	1132	2.72	1155	2.84	1179	2.97	1198	3.08	1216	3.18										
8160	1048	2.47	1074	2.60	1098	2.74	1122	2.87	1147	3.01	1170	3.14	1191	3.26	—	—	—	—	—	—										

**Notes:**

1. For Standard Evaporator Fan Speed (RPM), reference [Table 97, p. 117](#).
2. Data includes pressure drop due to standard filters and wet coils.
3. Refer to [Table 107, p. 119](#) to determine additional static pressure drop due to other options/accessories.
4. 2.24 kW Fan Motor Heat (kW) = 1.140 x kW - 0.110
5. Factory supplied motors, in commercial equipment, are definite purpose motors, specifically designed and tested to operate reliably and continuously at all cataloged conditions. Using the full horsepower range of our fan motors as shown in our tabular data will not result in nuisance tripping or premature motor failure. Our product's warranty will not be affected.

(a) BAYLSDR005A



## Evaporator Fan Performance

**Table 62. Belt drive evaporator fan performance—10 tons—TSC120ED—downflow airflow (IP)**

External Static Pressure (Inches of Water)																						
		.10		.20		.30		.40		.50		.60		.70		.80		.90		1.00		
cfm	rpm	bhp	rpm	bhp	rpm	bhp	rpm	bhp	rpm	bhp	rpm	bhp	rpm	bhp	rpm	bhp	rpm	bhp	rpm	bhp	rpm	bhp
<b>3-hp Std Motor &amp; Field Supplied Low Static Drive<sup>(a)</sup></b>																						
3200	—	—	—	—	—	—	—	—	703	1.00	741	1.12	776	1.23	808	1.35	841	1.47	871	1.58		
3600	—	—	—	—	—	—	703	1.10	743	1.24	780	1.37	814	1.51	846	1.64	877	1.78	906	1.90		
4000	—	—	—	—	704	1.20	746	1.36	784	1.51	819	1.67	853	1.82	885	1.97	915	2.12	943	2.27		
4400	—	—	704	1.31	749	1.49	789	1.66	826	1.84	861	2.01	894	2.18	925	2.35	953	2.51	983	2.68		
4800	705	1.41	752	1.62	794	1.82	833	2.01	869	2.21	903	2.40	934	2.58	965	2.77	994	2.95	1022	3.13		
<b>3-hp Std Motor &amp; Drive</b>																						

Continued

External Static Pressure (Inches of Water)																						
		1.10		1.20		1.30		1.40		1.50		1.60		1.70		1.80		1.90		2.00		
cfm	rpm	bhp	rpm	bhp	rpm	bhp	rpm	bhp	rpm	bhp	rpm	bhp	rpm	bhp	rpm	bhp	rpm	bhp	rpm	bhp	rpm	bhp
<b>3-hp Std. Motor &amp; Drive</b>																						
3200	894	1.67	916	1.76	944	1.87	972	2.00	999	2.13	1023	2.25	1047	2.37	1071	2.51	1095	2.65	1118	2.79		
3600	935	2.04	964	2.18	986	2.29	1007	2.39	1028	2.49	1051	2.61	1075	2.74	1100	2.89	1124	3.03	1146	3.16		
4000	971	2.42	998	2.56	1023	2.70	1050	2.86	1075	3.01	1096	3.14	1115	3.25	1133	3.36	1150	3.47	1172	3.61		
4400	1009	2.84	1036	3.01	1061	3.17	1086	3.33	1109	3.49	1132	3.64	1155	3.81	1179	3.98	1198	4.13	1216	4.26		
4800	1048	3.31	1074	3.49	1098	3.67	1122	3.85	1147	4.03	1170	4.21	1191	4.37	—	—	—	—	—	—		

**Notes:**

1. For Standard Evaporator Fan Speed (RPM), reference [Table 97, p. 117](#).
2. Data includes pressure drop due to standard filters and wet coils.
3. Refer to [Table 108, p. 119](#) to determine additional static pressure drop due to other options/accessories.
4. 3-hp Fan Motor Heat (MBh) = 2.900 x Fan bhp + 0.3800
5. Factory supplied motors, in commercial equipment, are definite purpose motors, specifically designed and tested to operate reliably and continuously at all cataloged conditions. Using the full horsepower range of our fan motors as shown in our tabular data will not result in nuisance tripping or premature motor failure. Our product's warranty will not be affected.

(a) BAYLSDR005A

## Evaporator Fan Performance

**Table 63. Belt drive evaporator fan performance—10 tons—TSC120ED—horizontal airflow (SI)**

																						External Static Pressure (Pascals)									
		25		50		75		100		125		150		175		200		225		250											
m <sup>3</sup> /h	rpm	rpm	kW	rpm	kW	rpm	kW	rpm	kW	rpm	kW	rpm	kW	rpm	kW	rpm	kW	rpm	kW	rpm	kW										
																						<b>2.24 Nom kW Std Motor &amp; Field Supplied Low Static Drive<sup>(a)</sup></b>									
5440	—	—	—	—	718	0.75	768	0.87	811	0.99	850	1.10	881	1.20	907	1.27	935	1.37	965	1.48											
6120	—	—	717	0.82	770	0.96	818	1.10	861	1.23	901	1.36	937	1.50	970	1.62	995	1.72	1018	1.80											
6800	716	0.89	773	1.05	823	1.21	869	1.36	911	1.51	950	1.66	987	1.81	1021	1.96	1052	2.10	1080	2.24											
7480	776	1.15	829	1.33	877	1.50	921	1.67	962	1.84	1000	2.01	1036	2.17	1070	2.33	1102	2.50	1132	2.65											
8160	836	1.45	887	1.65	932	1.84	974	2.03	1014	2.21	1051	2.40	1086	2.58	1119	2.76	1151	2.94	1182	3.12											
																						<b>2.24 Nom kW Standard Motor &amp; Drive</b>									

Continued

																						External Static Pressure (Pascals)									
		275		300		325		350		375		400		425		450		475		500											
m <sup>3</sup> /h	rpm	rpm	kW	rpm	kW	rpm	kW	rpm	kW	rpm	kW	rpm	kW	rpm	kW	rpm	kW	rpm	kW	rpm	kW										
																						<b>2.24 Nom kW Std. Motor &amp; Drive</b>									
5440	993	1.59	1019	1.69	1042	1.78	1065	1.87	1087	1.97	1108	2.06	1129	2.16	1151	2.26	1172	2.35	1193	2.46											
6120	1041	1.90	1069	2.02	1095	2.15	1120	2.27	1142	2.38	1163	2.48	1184	2.59	1204	2.70	1224	2.81	1243	2.92											
6800	1103	2.35	1124	2.44	1144	2.54	1167	2.66	1192	2.80	1216	2.95	1238	3.08	1258	3.20	1279	3.32	—	—											
7480	1161	2.82	1186	2.97	1208	3.10	1226	3.20	1245	3.30	1263	—	—	—	—	—	—	—	—	—											
8160	1211	3.29	—	—	—	—	—	—	—	—	—	—	—	—	—	—	—	—	—	—											
																						<b>2.24 Nom kW Std Motor &amp; Field Supplied High Static Drive<sup>(b)</sup></b>									

**Notes:**

1. For Standard Evaporator Fan Speed (RPM), reference [Table 97, p. 117](#).
2. Data includes pressure drop due to standard filters and wet coils.
3. Refer to [Table 108, p. 119](#) to determine additional static pressure drop due to other options/accessories.
4. 2.24 kW Fan Motor Heat (kW) = 1.140 x kW - 0.110
5. Factory supplied motors, in commercial equipment, are definite purpose motors, specifically designed and tested to operate reliably and continuously at all cataloged conditions. Using the full horsepower range of our fan motors as shown in our tabular data will not result in nuisance tripping or premature motor failure. Our product's warranty will not be affected.

(a) BAYLSDR005A  
(b) BAYHSDR013A



## Evaporator Fan Performance

**Table 64. Belt drive evaporator fan performance—10 tons—TSC120ED—horizontal airflow (IP)**

External Static Pressure (Inches of Water)																						
		.10		.20		.30		.40		.50		.60		.70		.80		.90		1.00		
cfm	rpm	bhp	rpm	bhp	rpm	bhp	rpm	bhp	rpm	bhp	rpm	bhp	rpm	bhp	rpm	bhp	rpm	bhp	rpm	bhp	rpm	bhp
<b>3-hp Std Motor &amp; Field Supplied Low Static Drive<sup>(a)</sup></b>																						
3200	—	—	—	—	718	1.01	768	1.17	811	1.32	850	1.48	881	1.61	907	1.71	935	1.83	965	1.99		
3600	—	—	717	1.10	770	1.29	818	1.47	861	1.65	901	1.83	937	2.01	970	2.18	995	2.30	1018	2.42		
4000	716	1.19	773	1.41	823	1.62	869	1.83	911	2.03	950	2.23	987	2.43	1021	2.62	1052	2.82	1080	3.01		
4400	776	1.54	829	1.78	877	2.01	921	2.24	962	2.47	1000	2.69	1036	2.91	1070	3.13	1102	3.35	1132	3.56		
4800	836	1.94	887	2.21	932	2.47	974	2.72	1014	2.97	1051	3.22	1086	3.45	1119	3.70	1151	3.94	1182	4.18		
<b>3-hp Std Motor &amp; Drive</b>																						

Continued

External Static Pressure (Inches of Water)																						
		1.10		1.20		1.30		1.40		1.50		1.60		1.70		1.80		1.90		2.00		
cfm	rpm	bhp	rpm	bhp	rpm	bhp	rpm	bhp	rpm	bhp	rpm	bhp	rpm	bhp	rpm	bhp	rpm	bhp	rpm	bhp	rpm	bhp
<b>3-hp Std. Motor &amp; Drive</b>																						
3200	993	2.13	1019	2.26	1042	2.38	1065	2.51	1087	2.64	1108	2.77	1129	2.90	1151	3.03	1172	3.16	1193	3.29		
3600	1041	2.54	1069	2.71	1095	2.89	1120	3.05	1142	3.19	1163	3.33	1184	3.47	1204	3.62	1224	3.76	1243	3.91		
4000	1103	3.15	1124	3.28	1144	3.41	1167	3.56	1192	3.76	1216	3.95	1238	4.13	1258	4.29	1279	4.46	—	—		
4400	1161	3.78	1186	3.98	1208	4.15	1226	4.28	1245	4.42	1263	—	—	—	—	—	—	—	—	—		
4800	1211	4.41	—	—	—	—	—	—	—	—	—	—	—	—	—	—	—	—	—	—		
<b>3-hp Std Motor &amp; Field Supplied High Static Drive<sup>(b)</sup></b>																						

**Notes:**

1. For Standard Evaporator Fan Speed (RPM), reference [Table 97, p. 117](#).
2. Data includes pressure drop due to standard filters and wet coils.
3. Refer to [Table 108, p. 119](#) to determine additional static pressure drop due to other options/accessories.
4. 3-hp Fan Motor Heat (MBh) = 2.900 x Fan bhp + 0.3800
5. Factory supplied motors, in commercial equipment, are definite purpose motors, specifically designed and tested to operate reliably and continuously at all cataloged conditions. Using the full horsepower range of our fan motors as shown in our tabular data will not result in nuisance tripping or premature motor failure. Our product's warranty will not be affected.

(a) BAYLSDR005A  
 (b) BAYHSDR013A



## Evaporator Fan Performance

**Table 65. Belt drive evaporator fan performance—10 tons—YSC120ED—low gas heat—downflow airflow (SI)**

																						External Static Pressure (Pascals)									
		25		50		75		100		125		150		175		200		225		250											
m <sup>3</sup> /h	rpm	kW	rpm	kW	rpm	kW	rpm	kW	rpm	kW	rpm	kW	rpm	kW	rpm	kW	rpm	kW	rpm	kW											
																						<b>2.24 Nom kW Std Motor &amp; Field Supplied Low Static Drive<sup>(a)</sup></b>									
5440	—	—	—	—	—	—	711	0.76	747	0.84	781	0.93	812	1.01	842	1.10	870	1.17	893	1.24											
6120	—	—	683	0.78	725	0.88	762	0.98	797	1.08	830	1.17	860	1.27	890	1.36	918	1.46	944	1.55											
6800	698	0.89	741	1.01	780	1.13	816	1.24	849	1.35	881	1.46	910	1.57	938	1.67	966	1.77	992	1.88											
7480	759	1.16	799	1.30	836	1.42	870	1.55	902	1.67	932	1.79	962	1.91	989	2.03	1015	2.14	1040	2.26											
8160	820	1.48	858	1.63	893	1.77	926	1.91	957	2.04	986	2.18	1014	2.31	1040	2.44	1066	2.57	1091	2.70											
																						<b>2.24 Nom kW Standard Motor &amp; Drive</b>									

**Continued**

																						External Static Pressure (Pascals)									
		275		300		325		350		375		400		425		450		475		500											
m <sup>3</sup> /h	rpm	kW	rpm	kW	rpm	kW	rpm	kW	rpm	kW	rpm	kW	rpm	kW	rpm	kW	rpm	kW	rpm	kW											
											<b>2.24 Nom kW Std Motor &amp; Field Supplied High Static Drive<sup>(b)</sup></b>																				
5440	917	1.32	942	1.40	970	1.49	994	1.58	1017	1.66	1040	1.74	1062	1.83	1084	1.91	1105	2.00	1126	2.09											
6120	969	1.64	992	1.72	1013	1.80	1034	1.88	1057	1.97	1079	2.07	1103	2.18	1124	2.27	1146	2.37	1165	2.46											
6800	1017	1.98	1041	2.09	1064	2.19	1086	2.29	1106	2.38	1124	2.46	1144	2.55	1163	2.65	1184	2.76	1206	2.88											
7480	1065	2.38	1089	2.49	1112	2.61	1134	2.72	1156	2.83	1176	2.94	1195	3.05	1213	3.15	1230	3.24	1247	3.34											
8160	1114	2.82	1137	2.95	1160	3.07	1181	3.19	1203	3.32	—	—	—	—	—	—	—	—	—	—											
											<b>2.24 Nom kW Std Motor &amp; Field Supplied High Static Drive<sup>(c)</sup></b>																				

**Notes:**

1. For Standard Evaporator Fan Speed (RPM), reference [Table 97, p. 117](#).
2. Data includes pressure drop due to standard filters and wet coils.
3. Refer to [Table 107, p. 119](#) to determine additional static pressure drop due to other options/accessories.
4. 2.24 kW Fan Motor Heat (kW) = 1.140 x kW - 0.110
5. Factory supplied motors, in commercial equipment, are definite purpose motors, specifically designed and tested to operate reliably and continuously at all cataloged conditions. Using the full horsepower range of our fan motors as shown in our tabular data will not result in nuisance tripping or premature motor failure. Our product's warranty will not be affected.

(a) BAYLSDR005A  
 (b) BAYLSDR005A  
 (c) BAYHSDR013A



## Evaporator Fan Performance

**Table 66. Belt drive evaporator fan performance—10 tons—YSC120ED—low gas heat—downflow airflow (IP)**

External Static Pressure (Inches of Water)																						
		.10		.20		.30		.40		.50		.60		.70		.80		.90		1.00		
cfm	rpm	bhp	rpm	bhp	rpm	bhp	rpm	bhp	rpm	bhp	rpm	bhp	rpm	bhp	rpm	bhp	rpm	bhp	rpm	bhp	rpm	bhp
<b>3-hp Std Motor &amp; Field Supplied Low Static Drive<sup>(a)</sup></b>																						
3200	—	—	—	—	—	—	711	1.02	747	1.13	781	1.24	812	1.36	842	1.47	870	1.57	893	1.67		
3600	—	—	683	1.04	725	1.18	762	1.31	797	1.44	830	1.57	860	1.70	890	1.82	918	1.95	944	2.07		
4000	698	1.20	741	1.36	780	1.51	816	1.67	849	1.81	881	1.96	910	2.10	938	2.24	966	2.38	992	2.52		
4400	759	1.56	799	1.74	836	1.91	870	2.08	902	2.24	932	2.40	962	2.56	989	2.72	1015	2.88	1040	3.03		
4800	820	1.99	858	2.18	893	2.37	926	2.56	957	2.74	986	2.92	1014	3.10	1040	3.27	1066	3.44	1091	3.61		
<b>3-hp Std Motor &amp; Drive</b>																						

Continued

External Static Pressure (Inches of Water)																						
		1.10		1.20		1.30		1.40		1.50		1.60		1.70		1.80		1.90		2.00		
cfm	rpm	bhp	rpm	bhp	rpm	bhp	rpm	bhp	rpm	bhp	rpm	bhp	rpm	bhp	rpm	bhp	rpm	bhp	rpm	bhp	rpm	bhp
<b>3-hp Std Motor &amp; Field Supplied Low Static Drive<sup>(b)</sup></b>											<b>3-hp Std. Motor &amp; Drive</b>											
3200	917	1.76	942	1.87	970	2.00	994	2.12	1017	2.22	1040	2.34	1062	2.45	1084	2.56	1105	2.68	1126	2.81		
3600	969	2.19	992	2.31	1013	2.41	1034	2.52	1057	2.65	1079	2.78	1103	2.92	1124	3.05	1146	3.17	1165	3.29		
4000	1017	2.66	1041	2.80	1064	2.93	1086	3.06	1106	3.18	1124	3.30	1144	3.42	1163	3.55	1184	3.70	1206	3.86		
4400	1065	3.19	1089	3.34	1112	3.49	1134	3.65	1156	3.80	1176	3.95	1195	4.09	1213	4.22	1230	4.35	1247	4.47		
4800	1114	3.78	1137	3.95	1160	4.12	1181	4.28	1203	4.45	—	—	—	—	—	—	—	—	—	—	—	—
<b>3-hp Std Motor &amp; Field Supplied High Static Drive<sup>(c)</sup></b>																						

**Notes:**

1. For Standard Evaporator Fan Speed (RPM), reference [Table 97, p. 117](#).
2. Data includes pressure drop due to standard filters and wet coils.
3. Refer to [Table 108, p. 119](#) to determine additional static pressure drop due to other options/accessories.
4. 3-hp Fan Motor Heat (MBh) = 2.900 x Fan bhp - .3800
5. Factory supplied motors, in commercial equipment, are definite purpose motors, specifically designed and tested to operate reliably and continuously at all cataloged conditions. Using the full horsepower range of our fan motors as shown in our tabular data will not result in nuisance tripping or premature motor failure. Our product's warranty will not be affected.

(a) BAYLSDR005A  
 (b) BAYLSDR005A  
 (c) BAYHSDR013A

## Evaporator Fan Performance

**Table 67. Belt drive evaporator fan performance—10 tons—YSC120ED—high gas heat—downflow airflow (SI)**

																						External Static Pressure (Pascals)									
		25		50		75		100		125		150		175		200		225		250											
m <sup>3</sup> /h	rpm	kW	rpm	kW	rpm	kW	rpm	kW	rpm	kW	rpm	kW	rpm	kW	rpm	kW	rpm	kW	rpm	kW											
																						<b>2.24 Nom kW Std Motor &amp; Field Supplied Low Static Drive<sup>(a)</sup></b>									
5440	—	—	—	—	695	0.70	734	0.79	769	0.87	804	0.96	839	1.05	870	1.13	896	1.20	920	1.27											
6120	—	—	712	0.82	752	0.92	789	1.02	823	1.11	855	1.21	886	1.30	918	1.40	948	1.51	976	1.60											
6800	731	0.95	773	1.07	811	1.18	846	1.29	879	1.40	909	1.51	939	1.61	966	1.72	995	1.82	1023	1.94											
7480	796	1.24	834	1.37	870	1.49	904	1.62	935	1.74	965	1.86	993	1.97	1020	2.09	1046	2.20	1071	2.32											
8160	861	1.58	897	1.72	931	1.86	963	1.99	993	2.13	1022	2.26	1048	2.39	1075	2.52	1101	2.65	1124	2.77											
																						<b>2.24 Nom kW Standard Motor &amp; Drive</b>									

**Continued**

																						External Static Pressure (Pascals)									
		275		300		325		350		375		400		425		450		475		500											
m <sup>3</sup> /h	rpm	kW	rpm	kW	rpm	kW	rpm	kW	rpm	kW	rpm	kW	rpm	kW	rpm	kW	rpm	kW	rpm	kW											
											<b>2.24 Nom kW Std Motor &amp; Field Supplied Low Static Drive<sup>(b)</sup></b>																				
											<b>2.24 Nom kW Std. Motor &amp; Drive</b>																				
5440	948	1.36	978	1.47	1005	1.56	1029	1.65	1054	1.74	1076	1.83	1099	1.92	1121	2.01	1142	2.09	1163	2.19											
6120	999	1.68	1021	1.75	1043	1.83	1069	1.94	1097	2.07	1121	2.18	1142	2.28	1165	2.38	1185	2.48	1206	2.58											
6800	1051	2.06	1076	2.17	1099	2.26	1119	2.34	1138	2.42	1158	2.51	1182	2.63	1206	2.77	1229	2.90	1251	3.02											
7480	1097	2.44	1123	2.57	1149	2.70	1172	2.82	1195	2.94	1214	3.03	1231	3.12	1249	3.21	1268	3.30	—	—											
8160	1148	2.90	1171	3.03	1194	3.16	1219	3.30	—	—	—	—	—	—	—	—	—	—	—	—											
																						<b>2.24 Nom kW Std Motor &amp; Field Supplied High Static Drive<sup>(c)</sup></b>									

**Notes:**

1. For Standard Evaporator Fan Speed (RPM), reference [Table 97, p. 117](#).
2. Data includes pressure drop due to standard filters and wet coils.
3. Refer to [Table 107, p. 119](#) to determine additional static pressure drop due to other options/accessories.
4. 2.24 kW Fan Motor Heat (kW) = 1.140 x kW - 0.110
5. Factory supplied motors, in commercial equipment, are definite purpose motors, specifically designed and tested to operate reliably and continuously at all cataloged conditions. Using the full horsepower range of our fan motors as shown in our tabular data will not result in nuisance tripping or premature motor failure. Our product's warranty will not be affected.

(a) BAYLSDR005A  
 (b) BAYLSDR005A  
 (c) BAYHSDR013A



## Evaporator Fan Performance

**Table 68. Belt drive evaporator fan performance—10 tons—YSC120ED—high gas heat—downflow airflow (IP)**

External Static Pressure (Inches of Water)																					
		.10		.20		.30		.40		.50		.60		.70		.80		.90		1.00	
cfm	rpm	bhp	rpm	bhp	rpm	bhp	rpm	bhp	rpm	bhp	rpm	bhp	rpm	bhp	rpm	bhp	rpm	bhp	rpm	bhp	
<b>3-hp Std Motor &amp; Field Supplied Low Static Drive<sup>(a)</sup></b>																					
3200	—	—	—	—	695	0.94	734	1.05	769	1.16	804	1.28	839	1.41	870	1.52	896	1.61	920	1.70	
3600	—	—	712	1.09	752	1.23	789	1.36	823	1.49	855	1.62	886	1.74	918	1.88	948	2.02	976	2.15	
4000	731	1.27	773	1.43	811	1.58	846	1.73	879	1.88	909	2.02	939	2.16	966	2.30	995	2.45	1023	2.60	
4400	796	1.66	834	1.83	870	2.00	904	2.17	935	2.33	965	2.49	993	2.65	1020	2.80	1046	2.95	1071	3.11	
4800	861	2.11	897	2.30	931	2.49	963	2.67	993	2.85	1022	3.03	1048	3.20	1075	3.38	1101	3.55	1124	3.72	
<b>3-hp Std Motor &amp; Drive</b>																					

Continued

External Static Pressure (Inches of Water)																					
		1.10		1.20		1.30		1.40		1.50		1.60		1.70		1.80		1.90		2.00	
cfm	rpm	bhp	rpm	bhp	rpm	bhp	rpm	bhp	rpm	bhp	rpm	bhp	rpm	bhp	rpm	bhp	rpm	bhp	rpm	bhp	
<b>3-hp Std Motor &amp; Field Supplied Low Static Drive<sup>(b)</sup></b>											<b>3-hp Std. Motor &amp; Drive</b>										
3200	948	1.82	978	1.97	1005	2.10	1029	2.21	1054	2.33	1076	2.45	1099	2.57	1121	2.69	1142	2.81	1163	2.93	
3600	999	2.25	1021	2.35	1043	2.45	1069	2.60	1097	2.77	1121	2.92	1142	3.05	1165	3.19	1185	3.32	1206	3.45	
4000	1051	2.75	1076	2.90	1099	3.03	1119	3.14	1138	3.24	1158	3.36	1182	3.52	1206	3.71	1229	3.89	1251	4.05	
4400	1097	3.28	1123	3.44	1149	3.62	1172	3.78	1195	3.94	1214	4.06	1231	4.18	1249	4.30	1268	4.43	—	—	
4800	1148	3.89	1171	4.06	1194	4.23	1219	4.42	—	—	—	—	—	—	—	—	—	—	—	—	
<b>3-hp Std Motor &amp; Field Supplied High Static Drive<sup>(c)</sup></b>																					

**Notes:**

1. For Standard Evaporator Fan Speed (RPM), reference [Table 97, p. 117](#).
2. Data includes pressure drop due to standard filters and wet coils.
3. Refer to [Table 108, p. 119](#) to determine additional static pressure drop due to other options/accessories.
4. 3-hp Fan Motor Heat (MBh) = 2.900 x Fan bhp + 0.3800
5. Factory supplied motors, in commercial equipment, are definite purpose motors, specifically designed and tested to operate reliably and continuously at all cataloged conditions. Using the full horsepower range of our fan motors as shown in our tabular data will not result in nuisance tripping or premature motor failure. Our product's warranty will not be affected.

(a) BAYLSDR005A  
 (b) BAYLSDR005A  
 (c) BAYHSDR013A

## Evaporator Fan Performance

**Table 69. Belt drive evaporator fan performance—10 tons—YSC120ED—low gas heat—horizontal airflow (SI)**

																					External Static Pressure (Pascals)									
		25		50		75		100		125		150		175		200		225		250										
m <sup>3</sup> /h	rpm	kW	rpm	kW	rpm	kW	rpm	kW	rpm	kW	rpm	kW	rpm	kW	rpm	kW	rpm	kW	rpm	kW										
<b>2.24 Nom kW Std Motor &amp; Field Supplied Low Static Drive<sup>(a)</sup></b>																														
5440	—	—	740	0.82	777	0.91	810	0.99	842	1.08	874	1.17	904	1.26	933	1.36	962	1.46	990	1.57										
6120	776	1.00	813	1.11	848	1.21	880	1.31	910	1.41	938	1.50	966	1.61	994	1.71	1020	1.81	1046	1.92										
6800	854	1.35	888	1.47	921	1.58	951	1.70	980	1.80	1006	1.91	1032	2.02	1057	2.13	1083	2.25	1107	2.36										
7480	932	1.77	964	1.90	995	2.03	1023	2.15	1051	2.28	1077	2.39	1101	2.51	1124	2.63	1148	2.76	1171	2.88										
8160	1011	2.27	1041	2.41	1069	2.55	1097	2.69	1123	2.83	1148	2.96	1172	3.09	1194	3.22	1215	3.35	—	—										
<b>2.24 Nom kW Standard Motor &amp; Drive</b>												<b>2.24 Nom kW Std Motor &amp; Field Supplied High Static Drive<sup>(b)</sup></b>																		

Continued

																					External Static Pressure (Pascals)									
		275		300		325		350		375		400		425		450		475		500										
m <sup>3</sup> /h	rpm	kW	rpm	kW	rpm	kW	rpm	kW	rpm	kW	rpm	kW	rpm	kW	rpm	kW	rpm	kW	rpm	kW										
<b>2.24 Nom kW Std. Motor &amp; Drive</b>																														
5440	1016	1.67	1042	1.77	1067	1.87	1090	1.98	1114	2.08	1138	2.19	1160	2.30	1183	2.40	1205	2.51	1226	2.62										
6120	1073	2.04	1098	2.16	1122	2.27	1145	2.39	1167	2.50	1190	2.61	1212	2.73	1233	2.85	1253	2.96	1274	3.09										
6800	1131	2.48	1155	2.59	1178	2.72	1202	2.86	1224	2.99	1246	3.11	1267	3.24	1287	3.36	—	—	—	—										
7480	1193	3.01	1216	3.13	1238	3.26	—	—	—	—	—	—	—	—	—	—	—	—	—	—										
8160	—	—	—	—	—	—	—	—	—	—	—	—	—	—	—	—	—	—	—	—										
<b>2.24 Nom kW Std Motor &amp; Field Supplied High Static Drive<sup>(c)</sup></b>																														

**Notes:**

1. For Standard Evaporator Fan Speed (RPM), reference [Table 97, p. 117](#).
2. Data includes pressure drop due to standard filters and wet coils.
3. Refer to [Table 107, p. 119](#) to determine additional static pressure drop due to other options/accessories.
4. 2.24 kW Fan Motor Heat (MBh) = 1.140 x kW - 0.110
5. Factory supplied motors, in commercial equipment, are definite purpose motors, specifically designed and tested to operate reliably and continuously at all cataloged conditions. Using the full horsepower range of our fan motors as shown in our tabular data will not result in nuisance tripping or premature motor failure. Our product's warranty will not be affected.

(a) BAYLSDR005A  
 (b) BAYHSDR013A  
 (c) BAYHSDR013A



## Evaporator Fan Performance

**Table 70. Belt drive evaporator fan performance—10 tons—YSC120ED—low gas heat—horizontal airflow (IP)**

External Static Pressure (Inches of Water)																						
		.10		.20		.30		.40		.50		.60		.70		.80		.90		1.00		
cfm	rpm	bhp	rpm	bhp	rpm	bhp	rpm	bhp	rpm	bhp	rpm	bhp	rpm	bhp	rpm	bhp	rpm	bhp	rpm	bhp	rpm	bhp
<b>3-hp Std Motor &amp; Field Supplied Low Static Drive<sup>(a)</sup></b>																						
3200	—	—	740	1.10	777	1.22	810	1.33	842	1.45	874	1.57	904	1.69	933	1.82	962	1.96	990	2.10		
3600	776	1.35	813	1.49	848	1.62	880	1.76	910	1.88	938	2.02	966	2.16	994	2.29	1020	2.43	1046	2.57		
4000	854	1.81	888	1.97	921	2.12	951	2.27	980	2.42	1006	2.56	1032	2.71	1057	2.86	1083	3.02	1107	3.17		
4400	932	2.37	964	2.55	995	2.72	1023	2.88	1051	3.05	1077	3.21	1101	3.37	1124	3.52	1148	3.69	1171	3.86		
4800	1011	3.04	1041	3.23	1069	3.42	1097	3.61	1123	3.79	1148	3.97	1172	4.15	1194	4.32	1215	4.49	—	—		
<b>3-hp Std Motor &amp; Drive</b>												<b>3-hp Std Motor &amp; Field Supplied High Static Drive<sup>(b)</sup></b>										

Continued

External Static Pressure (Inches of Water)																						
		1.10		1.20		1.30		1.40		1.50		1.60		1.70		1.80		1.90		2.00		
cfm	rpm	bhp	rpm	bhp	rpm	bhp	rpm	bhp	rpm	bhp	rpm	bhp	rpm	bhp	rpm	bhp	rpm	bhp	rpm	bhp	rpm	bhp
<b>3-hp Std. Motor &amp; Drive</b>																						
3200	1016	2.24	1042	2.37	1067	2.51	1090	2.65	1114	2.79	1138	2.94	1160	3.08	1183	3.22	1205	3.37	1226	3.51		
3600	1073	2.73	1098	2.89	1122	3.05	1145	3.20	1167	3.35	1190	3.50	1212	3.66	1233	3.82	1253	3.97	1274	4.14		
4000	1131	3.32	1155	3.47	1178	3.65	1202	3.83	1224	4.00	1246	4.17	1267	4.34	1287	4.51	—	—	—	—		
4400	1193	4.03	1216	4.20	1238	4.36	—	—	—	—	—	—	—	—	—	—	—	—	—	—		
4800	—	—	—	—	—	—	—	—	—	—	—	—	—	—	—	—	—	—	—	—		
<b>3-hp Std Motor &amp; Drive</b>												<b>3-hp Std Motor &amp; Field Supplied High Static Drive<sup>(c)</sup></b>										

**Notes:**

1. For Standard Evaporator Fan Speed (RPM), reference [Table 97, p. 117](#).
2. Data includes pressure drop due to standard filters and wet coils.
3. Refer to [Table 108, p. 119](#) to determine additional static pressure drop due to other options/accessories.
4. 3-hp Fan Motor Heat (MBh) = 2.900 x Fan bhp + 0.3800
5. Factory supplied motors, in commercial equipment, are definite purpose motors, specifically designed and tested to operate reliably and continuously at all cataloged conditions. Using the full horsepower range of our fan motors as shown in our tabular data will not result in nuisance tripping or premature motor failure. Our product's warranty will not be affected.

(a) BAYLSDR005A  
 (b) BAYHSDR013A  
 (c) BAYHSDR013A

## Evaporator Fan Performance

**Table 71. Belt drive evaporator fan performance—10 tons—YSC120ED—high gas heat—horizontal airflow (SI)**

																					External Static Pressure (Pascals)									
		25		50		75		100		125		150		175		200		225		250										
m <sup>3</sup> /h	rpm	kW	rpm	kW	rpm	kW	rpm	kW	rpm	kW	rpm	kW	rpm	kW	rpm	kW	rpm	kW	rpm	kW										
															<b>2.24 Nom kW Std Motor &amp; Field Supplied Low Static Drive<sup>(a)</sup></b>					<b>2.24 Nom kW Standard Motor &amp; Drive</b>										
5440	754	0.83	789	0.92	823	1.01	855	1.10	884	1.18	912	1.27	939	1.35	967	1.45	994	1.55	1019	1.64										
6120	839	1.15	871	1.26	902	1.36	931	1.46	960	1.56	986	1.66	1011	1.75	1035	1.84	1060	1.94	1085	2.05										
6800	925	1.55	955	1.67	983	1.78	1010	1.90	1037	2.01	1062	2.12	1086	2.23	1109	2.33	1131	2.43	1153	2.54										
7480	1011	2.04	1039	2.17	1065	2.29	1091	2.42	1115	2.55	1139	2.67	1162	2.79	1185	2.91	1206	3.03	1227	3.14										
8160	1098	2.62	1124	2.76	1149	2.90	1172	3.04	1195	3.17	1218	3.31	—	—	—	—	—	—	—	—										
															<b>2.24 Nom kW Std Motor &amp; Field Supplied High Static Drive<sup>(b)</sup></b>															

Continued

																					External Static Pressure (Pascals)									
		275		300		325		350		375		400		425		450		475		500										
m <sup>3</sup> /h	rpm	kW	rpm	kW	rpm	kW	rpm	kW	rpm	kW	rpm	kW	rpm	kW	rpm	kW	rpm	kW	rpm	kW										
<b>2.24 Nom kW Std. Motor &amp; Drive</b>																														
5440	1044	1.74	1068	1.83	1092	1.93	1115	2.02	1138	2.12	1160	2.22	1182	2.32	1204	2.43	1225	2.53	1246	2.64										
6120	1109	2.16	1132	2.27	1154	2.37	1176	2.48	1198	2.59	1219	2.69	1239	2.80	1260	2.91	1280	3.02	1300	3.13										
6800	1175	2.65	1198	2.78	1220	2.90	1241	3.01	1261	3.13	1282	3.25	—	—	—	—	—	—	—	—										
7480	1246	3.25	—	—	—	—	—	—	—	—	—	—	—	—	—	—	—	—	—	—										
8160	—	—	—	—	—	—	—	—	—	—	—	—	—	—	—	—	—	—	—	—										
<b>2.24 Nom kW Std Motor &amp; Field Supplied High Static Drive<sup>(c)</sup></b>																														

**Notes:**

1. For Standard Evaporator Fan Speed (RPM), reference [Table 97, p. 117](#).
2. Data includes pressure drop due to standard filters and wet coils.
3. Refer to [Table 107, p. 119](#) to determine additional static pressure drop due to other options/accessories.
4. 2.24 kW Fan Motor Heat (MBh) = 1.140 x kW - .110
5. Factory supplied motors, in commercial equipment, are definite purpose motors, specifically designed and tested to operate reliably and continuously at all cataloged conditions. Using the full horsepower range of our fan motors as shown in our tabular data will not result in nuisance tripping or premature motor failure. Our product's warranty will not be affected.

(a) BAYLSDR005A  
 (b) BAYHSDR013A  
 (c) BAYHSDR013A



## Evaporator Fan Performance

**Table 72. Belt drive evaporator fan performance—10 tons—YSC120ED—high gas heat—horizontal airflow (IP)**

External Static Pressure (Inches of Water)																					
		.10		.20		.30		.40		.50		.60		.70		.80		.90		1.00	
cfm	rpm	bhp	rpm	bhp	rpm	bhp	rpm	bhp	rpm	bhp	rpm	bhp	rpm	bhp	rpm	bhp	rpm	bhp	rpm	bhp	
3-hp Std Motor & Field Supplied Low Static Drive <sup>(a)</sup>														3-hp Std Motor & Drive							
3200	754	1.11	789	1.23	823	1.36	855	1.47	884	1.59	912	1.70	939	1.81	967	1.94	994	2.07	1019	2.20	
3600	839	1.54	871	1.68	902	1.82	931	1.96	960	2.09	986	2.22	1011	2.34	1035	2.47	1060	2.61	1085	2.75	
4000	925	2.08	955	2.24	983	2.39	1010	2.54	1037	2.69	1062	2.84	1086	2.99	1109	3.13	1131	3.26	1153	3.40	
4400	1011	2.73	1039	2.91	1065	3.08	1091	3.25	1115	3.41	1139	3.58	1162	3.74	1185	3.90	1206	4.06	1227	4.21	
4800	1098	3.51	1124	3.70	1149	3.89	1172	4.07	1195	4.26	1218	4.44	—	—	—	—	—	—	—	—	
														3-hp Std Motor & Field Supplied High Static Drive <sup>(b)</sup>							

Continued

External Static Pressure (Inches of Water)																					
		1.10		1.20		1.30		1.40		1.50		1.60		1.70		1.80		1.90		2.00	
cfm	rpm	bhp	rpm	bhp	rpm	bhp	rpm	bhp	rpm	bhp	rpm	bhp	rpm	bhp	rpm	bhp	rpm	bhp	rpm	bhp	
3-hp Std. Motor & Drive																					
3200	1044	2.33	1068	2.45	1092	2.58	1115	2.71	1138	2.84	1160	2.98	1182	3.11	1204	3.26	1225	3.40	1246	3.54	
3600	1109	2.90	1132	3.04	1154	3.18	1176	3.32	1198	3.47	1219	3.61	1239	3.75	1260	3.90	1280	4.05	1300	4.20	
4000	1175	3.55	1198	3.72	1220	3.88	1241	4.04	1261	4.20	1282	4.36	—	—	—	—	—	—	—	—	
4400	1246	4.36	—	—	—	—	—	—	—	—	—	—	—	—	—	—	—	—	—	—	
4800	—	—	—	—	—	—	—	—	—	—	—	—	—	—	—	—	—	—	—	—	
														3-hp Std Motor & Field Supplied High Static Drive <sup>(c)</sup>							

**Notes:**

1. For Standard Evaporator Fan Speed (RPM), reference [Table 97, p. 117](#).
2. Data includes pressure drop due to standard filters and wet coils.
3. Refer to [Table 108, p. 119](#) to determine additional static pressure drop due to other options/accessories.
4. 3-hp Fan Motor Heat (MBh) = 2.900 x Fan bhp - .3800
5. Factory supplied motors, in commercial equipment, are definite purpose motors, specifically designed and tested to operate reliably and continuously at all cataloged conditions. Using the full horsepower range of our fan motors as shown in our tabular data will not result in nuisance tripping or premature motor failure. Our product's warranty will not be affected.

(a) BAYLSDR005A  
 (b) BAYHSDR013A  
 (c) BAYHSDR013A



## Evaporator Fan Performance

**Table 73. Belt drive evaporator fan performance—10 tons—WSC120ED—downflow airflow (SI)**

External Static Pressure (Pascals)																						
		25		50		75		100		125		150		175		200		225		250		
m <sup>3</sup> /h	rpm	rpm	kW	rpm	kW	rpm	kW	rpm	kW	rpm	kW	rpm	kW	rpm	kW	rpm	kW	rpm	kW	rpm	kW	
<b>2.24 Nom kW Std Motor &amp; Field Supplied Low Static Drive<sup>(a)</sup></b>																						
5440	—	—	—	—	—	—	—	—	—	703	0.74	741	0.83	776	0.92	808	1.00	841	1.10	871	1.18	
6120	—	—	—	—	—	—	—	703	0.82	743	0.92	780	1.02	814	1.12	846	1.22	877	1.33	906	1.42	
6800	—	—	—	—	704	0.90	746	1.02	784	1.13	819	1.24	853	1.36	885	1.47	915	1.58	943	1.69		
7480	—	—	704	0.97	749	1.11	789	1.24	826	1.37	861	1.50	894	1.63	925	1.75	953	1.87	983	2.00		
8160	705	1.05	752	1.21	794	1.36	833	1.50	869	1.65	903	1.79	934	1.93	965	2.06	994	2.20	1022	2.34		
<b>2.24 Nom kW Standard Motor &amp; Drive</b>																						

**Continued**

External Static Pressure (Pascals)																						
		275		300		325		350		375		400		425		450		475		500		
m <sup>3</sup> /h	rpm	rpm	kW	rpm	kW	rpm	kW	rpm	kW	rpm	kW	rpm	kW	rpm	kW	rpm	kW	rpm	kW	rpm	kW	
<b>2.24 Nom kW Std. Motor &amp; Drive</b>																						
5440	894	1.25	916	1.31	944	1.40	972	1.49	999	1.59	1023	1.67	1047	1.77	1071	1.87	1095	1.98	1118	2.08		
6120	935	1.52	964	1.62	986	1.71	1007	1.78	1028	1.86	1051	1.95	1075	2.05	1100	2.15	1124	2.26	1146	2.36		
6800	971	1.80	998	1.91	1023	2.02	1050	2.14	1075	2.25	1096	2.34	1115	2.43	1133	2.51	1150	2.59	1172	2.69		
7480	1009	2.12	1036	2.24	1061	2.36	1086	2.48	1109	2.60	1132	2.72	1155	2.84	1179	2.97	1198	3.08	1216	3.18		
8160	1048	2.47	1074	2.60	1098	2.74	1122	2.87	1147	3.01	1170	3.14	1191	3.26	—	—	—	—	—	—		

**Notes:**

1. For Standard Evaporator Fan Speed (RPM), reference [Table 101, p. 117](#).
2. Data includes pressure drop due to standard filters and wet coils.
3. Refer to [Table 109, p. 120](#) to determine additional static pressure drop due to other options/accessories.
4. 2.24 kW Fan Motor Heat (MBh) = 1.140 x Fan kW + 0.110
5. Factory supplied motors, in commercial equipment, are definite purpose motors, specifically designed and tested to operate reliably and continuously at all cataloged conditions. Using the full horsepower range of our fan motors as shown in our tabular data will not result in nuisance tripping or premature motor failure. Our product's warranty will not be affected.

(a) BAYLSDR005A



## Evaporator Fan Performance

**Table 74. Belt drive evaporator fan performance—10 tons—WSC120ED—downflow airflow (IP)**

External Static Pressure (Inches of Water)																						
		.10		.20		.30		.40		.50		.60		.70		.80		.90		1.00		
cfm	rpm	bhp	rpm	bhp	rpm	bhp	rpm	bhp	rpm	bhp	rpm	bhp	rpm	bhp	rpm	bhp	rpm	bhp	rpm	bhp	rpm	bhp
<b>3-hp Std Motor &amp; Field Supplied Low Static Drive<sup>(a)</sup></b>																						
3200	—	—	—	—	—	—	—	—	703	1.00	741	1.12	776	1.23	808	1.35	841	1.47	871	1.58		
3600	—	—	—	—	—	—	703	1.10	743	1.24	780	1.37	814	1.51	846	1.64	877	1.78	906	1.90		
4000	—	—	—	—	704	1.20	746	1.36	784	1.51	819	1.67	853	1.82	885	1.97	915	2.12	943	2.27		
4400	—	—	704	1.31	749	1.49	789	1.66	826	1.84	861	2.01	894	2.18	925	2.35	953	2.51	983	2.68		
4800	705	1.41	752	1.62	794	1.82	833	2.01	869	2.21	903	2.40	934	2.58	965	2.77	994	2.95	1022	3.13		
<b>3-hp Std Motor &amp; Drive</b>																						

Continued

External Static Pressure (Inches of Water)																						
		1.10		1.20		1.30		1.40		1.50		1.60		1.70		1.80		1.90		2.00		
cfm	rpm	bhp	rpm	bhp	rpm	bhp	rpm	bhp	rpm	bhp	rpm	bhp	rpm	bhp	rpm	bhp	rpm	bhp	rpm	bhp	rpm	bhp
<b>3-hp Std. Motor &amp; Drive</b>																						
3200	894	1.67	916	1.76	944	1.87	972	2.00	999	2.13	1023	2.25	1047	2.37	1071	2.51	1095	2.65	1118	2.79		
3600	935	2.04	964	2.18	986	2.29	1007	2.39	1028	2.49	1051	2.61	1075	2.74	1100	2.89	1124	3.03	1146	3.16		
4000	971	2.42	998	2.56	1023	2.70	1050	2.86	1075	3.01	1096	3.14	1115	3.25	1133	3.36	1150	3.47	1172	3.61		
4400	1009	2.84	1036	3.01	1061	3.17	1086	3.33	1109	3.49	1132	3.64	1155	3.81	1179	3.98	1198	4.13	1216	4.26		
4800	1048	3.31	1074	3.49	1098	3.67	1122	3.85	1147	4.03	1170	4.21	1191	4.37	—	—	—	—	—	—		

**Notes:**

1. For Standard Evaporator Fan Speed (RPM), reference [Table 101, p. 117](#).
2. Data includes pressure drop due to standard filters and wet coils.
3. Refer to [Table 110, p. 120](#) to determine additional static pressure drop due to other options/accessories.
4. 3-hp Fan Motor Heat (MBh) = 2.900 x Fan bhp + 0.3800
5. Factory supplied motors, in commercial equipment, are definite purpose motors, specifically designed and tested to operate reliably and continuously at all cataloged conditions. Using the full horsepower range of our fan motors as shown in our tabular data will not result in nuisance tripping or premature motor failure. Our product's warranty will not be affected.

(a) BAYLSDR005A

## Evaporator Fan Performance

**Table 75. Belt drive evaporator fan performance—10 tons—WSC120ED—horizontal airflow (SI)**

																					External Static Pressure (Pascals)									
		25		50		75		100		125		150		175		200		225		250										
m <sup>3</sup> /h	rpm	rpm	kW	rpm	kW	rpm	kW	rpm	kW	rpm	kW	rpm	kW	rpm	kW	rpm	kW	rpm	kW	rpm	kW									
																					<b>2.24 Nom kW Std Motor &amp; Field Supplied Low Static Drive<sup>(a)</sup></b>									
5440	—	—	—	—	718	0.75	768	0.87	811	0.99	850	1.10	881	1.20	907	1.27	935	1.37	965	1.48										
6120	—	—	717	0.82	770	0.96	818	1.10	861	1.23	901	1.36	937	1.50	970	1.62	995	1.72	1018	1.80										
6800	716	0.89	773	1.05	823	1.21	869	1.36	911	1.51	950	1.66	987	1.81	1021	1.96	1052	2.10	1080	2.24										
7480	776	1.15	829	1.33	877	1.50	921	1.67	962	1.84	1000	2.01	1036	2.17	1070	2.33	1102	2.50	1132	2.65										
8160	836	1.45	887	1.65	932	1.84	974	2.03	1014	2.21	1051	2.40	1086	2.58	1119	2.76	1151	2.94	1182	3.12										
																					<b>2.24 Nom kW Standard Motor &amp; Drive</b>									

**Continued**

																					External Static Pressure (Pascals)									
		275		300		325		350		375		400		425		450		475		500										
m <sup>3</sup> /h	rpm	rpm	kW	rpm	kW	rpm	kW	rpm	kW	rpm	kW	rpm	kW	rpm	kW	rpm	kW	rpm	kW	rpm	kW									
																					<b>2.24 Nom kW Std. Motor &amp; Drive</b>									
5440	993	1.59	1019	1.69	1042	1.78	1065	1.87	1087	1.97	1108	2.06	1129	2.16	1151	2.26	1172	2.35	1193	2.46										
6120	1041	1.90	1069	2.02	1095	2.15	1120	2.27	1142	2.38	1163	2.48	1184	2.59	1204	2.70	1224	2.81	1243	2.92										
6800	1103	2.35	1124	2.44	1144	2.54	1167	2.66	1192	2.80	1216	2.95	1238	3.08	1258	3.20	1279	3.32	—	—										
7480	1161	2.82	1186	2.97	1208	3.10	1226	3.20	1245	3.30	1263	—	—	—	—	—	—	—	—	—										
8160	1211	3.29	—	—	—	—	—	—	—	—	—	—	—	—	—	—	—	—	—	—										
																					<b>2.24 Nom kW Std Motor &amp; Field Supplied High Static Drive<sup>(b)</sup></b>									

**Notes:**

1. For Standard Evaporator Fan Speed (RPM), reference [Table 101, p. 117](#).
2. Data includes pressure drop due to standard filters and wet coils.
3. Refer to [Table 109, p. 120](#) to determine additional static pressure drop due to other options/accessories.
4. 2.24 kW Fan Motor Heat (MBh) = 1.140 x Fan kW - 0.110
5. Factory supplied motors, in commercial equipment, are definite purpose motors, specifically designed and tested to operate reliably and continuously at all cataloged conditions. Using the full horsepower range of our fan motors as shown in our tabular data will not result in nuisance tripping or premature motor failure. Our product's warranty will not be affected.

(a) BAYLSDR005A  
(b) BAYHSDR013A



## Evaporator Fan Performance

**Table 76. Belt drive evaporator fan performance—10 tons—WSC120ED—horizontal airflow (IP)**

External Static Pressure (Inches of Water)																					
		.10		.20		.30		.40		.50		.60		.70		.80		.90		1.00	
cfm	rpm	bhp	rpm	bhp	rpm	bhp	rpm	bhp	rpm	bhp	rpm	bhp	rpm	bhp	rpm	bhp	rpm	bhp	rpm	bhp	
<b>3-hp Std Motor &amp; Field Supplied Low Static Drive<sup>(a)</sup></b>																					
3200	—	—	—	—	718	1.01	768	1.17	811	1.32	850	1.48	881	1.61	907	1.71	935	1.83	965	1.99	
3600	—	—	717	1.10	770	1.29	818	1.47	861	1.65	901	1.83	937	2.01	970	2.18	995	2.30	1018	2.42	
4000	716	1.19	773	1.41	823	1.62	869	1.83	911	2.03	950	2.23	987	2.43	1021	2.62	1052	2.82	1080	3.01	
4400	776	1.54	829	1.78	877	2.01	921	2.24	962	2.47	1000	2.69	1036	2.91	1070	3.13	1102	3.35	1132	3.56	
4800	836	1.94	887	2.21	932	2.47	974	2.72	1014	2.97	1051	3.22	1086	3.45	1119	3.70	1151	3.94	1182	4.18	
<b>3-hp Std Motor &amp; Drive</b>																					

Continued

External Static Pressure (Inches of Water)																					
		1.10		1.20		1.30		1.40		1.50		1.60		1.70		1.80		1.90		2.00	
cfm	rpm	bhp	rpm	bhp	rpm	bhp	rpm	bhp	rpm	bhp	rpm	bhp	rpm	bhp	rpm	bhp	rpm	bhp	rpm	bhp	
<b>3-hp Std. Motor &amp; Drive</b>																					
3200	993	2.13	1019	2.26	1042	2.38	1065	2.51	1087	2.64	1108	2.77	1129	2.90	1151	3.03	1172	3.16	1193	3.29	
3600	1041	2.54	1069	2.71	1095	2.89	1120	3.05	1142	3.19	1163	3.33	1184	3.47	1204	3.62	1224	3.76	1243	3.91	
4000	1103	3.15	1124	3.28	1144	3.41	1167	3.56	1192	3.76	1216	3.95	1238	4.13	1258	4.29	1279	4.46	—	—	
4400	1161	3.78	1186	3.98	1208	4.15	1226	4.28	1245	4.42	1263	—	—	—	—	—	—	—	—	—	
4800	1211	4.41	—	—	—	—	—	—	—	—	—	—	—	—	—	—	—	—	—	—	
<b>3-hp Std Motor &amp; Field Supplied High Static Drive<sup>(b)</sup></b>																					

**Notes:**

1. For Standard Evaporator Fan Speed (RPM), reference [Table 101, p. 117](#).
2. Data includes pressure drop due to standard filters and wet coils.
3. Refer to [Table 110, p. 120](#) to determine additional static pressure drop due to other options/accessories.
4. 3-hp Fan Motor Heat (MBh) = 2.900 x Fan bhp + 0.3800
5. Factory supplied motors, in commercial equipment, are definite purpose motors, specifically designed and tested to operate reliably and continuously at all cataloged conditions. Using the full horsepower range of our fan motors as shown in our tabular data will not result in nuisance tripping or premature motor failure. Our product's warranty will not be affected.

(a) BAYLSDR005A  
(b) BAYHSDR013A



# Fan Performance

**Table 1. Standard motor & sheave/fan speed (rpm)**

Tons	Unit Model Number	Fan Sheave	6 Turns Open	5 Turns Open	4 Turns Open	3 Turns Open	2 Turns Open	1 Turn Open	Closed
5	T/YSC060ED	AK44x3/4"	N/A	1070	1138	1206	1274	1341	1409
6	T/YSC072ED	AK56x1"	N/A	822	874	926	978	1030	1082
7½	T/YSC090ED	AK57x1"	904	951	998	1045	1093	1140	N/A
8.5	T/YSC102ED	AK62x1"	797	838	878	919	960	1000	N/A
10	T/YSC120ED	AK105X1"	956	1006	1057	1107	1158	1208	N/A

Note: Factory set at 3 turns open.

**Table 2. Standard motor & low static drive accessory sheave/fan speed (rpm)**

Tons	Unit Model Number	Fan Sheave	6 Turns Open	5 Turns Open	4 Turns Open	3 Turns Open	2 Turns Open	1 Turn Open	Closed
5	T/YSC060ED	AK44x3/4"	N/A	720	791	861	931	1002	1072
6	T/YSC072ED	AK56x1"	N/A	558	612	665	718	772	825
7½	T/YSC090ED	AK57x1"	N/A	688	737	787	837	887	N/A
8½	T/YSC102ED	AK62x1"	N/A	606	651	695	739	784	N/A
10	T/YSC120ED	AK105X1"	N/A	724	776	828	880	932	984

Note: Factory set at 3 turns open.

**Table 3. Standard motor & high static drive accessory sheave/fan speed (rpm)**

Tons	Unit Model Number	Fan Sheave	6 Turns Open	5 Turns Open	4 Turns Open	3 Turns Open	2 Turns Open	1 Turn Open	Closed
6	T/YSC072ED	AK56x1"	N/A	968	1018	1068	1118	1169	1219
7½	T/YSC090ED	AK57x1"	1053	1091	1129	1166	1204	1242	N/A
8½	T/YSC102ED	AK62x1"	926	964	1002	1041	1079	1118	N/A
10	T/YSC120ED	AK105X1"	1110	1159	1209	1258	1308	1357	N/A

Note: Factory set at 3 turns open.

**Table 4. Oversized motor & drive sheave/fan speed (rpm)**

Tons	Unit Model Number	Fan Sheave	6 Turns Open	5 Turns Open	4 Turns Open	3 Turns Open	2 Turns Open	1 Turn Open	Closed
7½	T/YSC090ED	AK85x1"	1186	1249	1311	1373	1436	N/A	N/A
8½	T/YSC102ED	AK85x1"	1036	1093	1151	1208	1266	1323	N/A

Notes: Factory set at 3 turns open.

\* Indicates both standard and high efficiency units and both ReliaTel™ and electromechanical controls.

**Table 5. Standard motor & sheave/fan speed (rpm)**

Tons	Unit Model Number	Fan Sheave	6 Turns Open	5 Turns Open	4 Turns Open	3 Turns Open	2 Turns Open	1 Turn Open	Closed
5	WSC060ED	AK44x3/4"	N/A	1070	1138	1206	1274	1341	1409
6	WSC072ED	AK56x1"	N/A	822	874	926	978	1030	1082
7½	WSC090ED	AK57x1"	904	951	998	1045	1093	1140	N/A
10	WSC120ED	AK105X1"	956	1006	1057	1107	1158	1208	N/A

Note: Factory set at 3 turns open.



## Fan Performance

**Table 6. Standard motor & low static drive accessory sheave/fan speed (rpm)**

Tons	Unit Model Number	Fan Sheave	6 Turns Open	5 Turns Open	4 Turns Open	3 Turns Open	2 Turns Open	1 Turn Open	Closed
5	WSC060ED	AK44x3/4"	N/A	720	791	861	931	1002	1072
6	WSC072ED	AK56x1"	N/A	558	612	665	718	772	825
7½	WSC090ED	AK57x1"	N/A	688	737	787	837	887	N/A
10	WSC120ED	AK105X1"	N/A	724	776	828	880	932	984

Note: Factory set at 3 turns open.

**Table 7. Standard motor & high static drive accessory sheave/fan speed (rpm)**

Tons	Unit Model Number	Fan Sheave	6 Turns Open	5 Turns Open	4 Turns Open	3 Turns Open	2 Turns Open	1 Turn Open	Closed
6	WSC072ED	AK56x1"	N/A	968	1018	1068	1118	1169	1219
7½	WSC090ED	AK57x1"	1053	1091	1129	1166	1204	1242	N/A
10	WSC120ED	AK105X1"	1110	1159	1209	1258	1308	1357	N/A

Note: Factory set at 3 turns open.

**Table 8. Oversized motor & high static drive accessory sheave/fan speed (rpm)**

Tons	Unit Model Number	Fan Sheave	6 Turns Open	5 Turns Open	4 Turns Open	3 Turns Open	2 Turns Open	1 Turn Open	Closed
7½	WSC090ED	AK85x1"	1186	1249	1311	1373	1436	N/A	N/A

Note: Factory set at 3 turns open.

**Table 9. Outdoor sound power level—dB (ref. 10—2 W)**

Tons	Unit Model Number	Octave Center Frequency								Overall dBA
		63	125	250	500	1000	2000	4000	8000	
5	T/YSC060ED	84	91	79	77	74	71	68	63	80
6	T/YSC072ED	83	90	86	82	79	75	70	63	85
7½	T/YSC090ED	83	90	86	83	80	75	71	64	85
8.5	T/YSC102ED	83	89	84	81	77	72	69	62	83
10	T/YSC120ED	83	86	80	77	73	69	66	60	79

Note: Tests follow ARI270-95.

**Table 10. Outdoor sound power level—dB (ref. 10—12 W)**

Tons	Unit Model Number	Octave Center Frequency								Overall dBA
		63	125	250	500	1000	2000	4000	8000	
5	WSC060ED	84	91	79	77	74	71	68	63	80
6	WSC072ED	83	90	86	82	79	75	70	63	85
7½	WSC090ED	83	90	86	83	80	75	71	64	85
10	WSC120ED	83	86	80	77	73	69	66	60	79

Note: Tests follow ARI270-95.

**Table 11. Static pressure drop through accessories (pascals)—5 to 10 tons**

Tons	Unit Model Number	Airflow (m <sup>3</sup> /h)	Standard Filters <sup>(a)</sup>	2" MERV 8 Filter	2" MERV 13 Filter	Economizer with OA/RA Dampers <sup>(b)</sup>				Electric Heater Accessory (kW) <sup>(c),(d)</sup>		
						100% OA	100% RA	100% OA	100% RA	9	13-27	40
						Downflow		Horizontal				
5	T/YSC060ED	1600	0.04	0.07	0.07	0.13	0.04	0.13	0.02	0.05	0.05	—
5	T/YSC060ED	2000	0.06	0.10	0.09	0.18	0.07	0.18	0.02	0.07	0.08	—
5	T/YSC060ED	2400	0.08	0.13	0.10	0.25	0.11	0.25	0.03	0.10	0.12	—
6	T/YSC072ED	1920	0.04	0.07	0.10	0.10	0.01	0.06	0.02	—	0.02	—
6	T/YSC072ED	2400	0.06	0.09	0.13	0.11	0.02	0.08	0.02	—	0.03	—
6	T/YSC072ED	2880	0.09	0.12	0.15	0.13	0.04	0.10	0.04	—	0.05	—
7½	T/YSC090ED	2400	0.04	0.06	0.12	0.11	0.02	0.08	0.02	—	0.02	—
7½	T/YSC090ED	3000	0.06	0.09	0.13	0.14	0.05	0.12	0.05	—	0.03	—
7½	T/YSC090ED	3600	0.09	0.13	0.15	0.21	0.07	0.25	0.08	—	0.05	—
8½	T/YSC102ED	2720	0.05	0.08	0.13	0.12	0.03	0.09	0.04	—	0.03	—
8½	T/YSC102ED	3400	0.08	0.11	0.14	0.19	0.06	0.18	0.06	—	0.04	—
8½	T/YSC102ED	4080	0.12	0.16	0.16	0.30	0.07	0.31	0.09	—	0.06	—
10	T/YSC120ED	3200	0.07	0.10	0.14	0.17	0.05	0.14	0.05	—	0.03	0.05
10	T/YSC120ED	4000	0.11	0.15	0.16	0.26	0.07	0.30	0.08	—	0.03	0.05
10	T/YSC120ED	4800	0.16	0.20	0.18	0.34	0.09	0.35	0.10	—	0.04	0.06

(a) Tested with standard filters. Difference in pressure drop should be considered when utilizing optional 2" MERV 8 and MERV 13 filters.

(b) OA = Outside Air and RA = Return Air.

(c) Nominal kW ratings at 415 volts. Heaters only available on T units.

(d) Electric heaters restricted on applications below 320 cfm/ton.

**Table 12. Static pressure drop through accessories (inches water column)—5 to 10 tons**

Tons	Unit Model Number	cfm	Standard Filters <sup>(a)</sup>	2" MERV 8 Filter	2" MERV 13 Filter	Economizer with OA/RA Dampers <sup>(b)</sup>				Electric Heater Accessory (kW) <sup>(c),(d)</sup>		
						100% OA	100% RA	100% OA	100% RA	9	13-27	40
						Downflow		Horizontal				
5	T/YSC060ED	1600	0.04	0.07	0.07	0.13	0.04	0.13	0.02	0.05	0.05	—
5	T/YSC060ED	2000	0.06	0.10	0.09	0.18	0.07	0.18	0.02	0.07	0.08	—
5	T/YSC060ED	2400	0.08	0.13	0.10	0.25	0.11	0.25	0.03	0.10	0.12	—
6	T/YSC072ED	1920	0.04	0.07	0.10	0.10	0.01	0.06	0.02	—	0.02	—
6	T/YSC072ED	2400	0.06	0.09	0.13	0.11	0.02	0.08	0.02	—	0.03	—
6	T/YSC072ED	2880	0.09	0.12	0.15	0.13	0.04	0.10	0.04	—	0.05	—
7½	T/YSC090ED	2400	0.04	0.06	0.12	0.11	0.02	0.08	0.02	—	0.02	—
7½	T/YSC090ED	3000	0.06	0.09	0.13	0.14	0.05	0.12	0.05	—	0.03	—
7½	T/YSC090ED	3600	0.09	0.13	0.15	0.21	0.07	0.25	0.08	—	0.05	—
8½	T/YSC102ED	2720	0.05	0.08	0.13	0.12	0.03	0.09	0.04	—	0.03	—
8½	T/YSC102ED	3400	0.08	0.11	0.14	0.19	0.06	0.18	0.06	—	0.04	—
8½	T/YSC102ED	4080	0.12	0.16	0.16	0.30	0.07	0.31	0.09	—	0.06	—
10	T/YSC120ED	3200	0.07	0.10	0.14	0.17	0.05	0.14	0.05	—	0.03	0.05
10	T/YSC120ED	4000	0.11	0.15	0.16	0.26	0.07	0.30	0.08	—	0.03	0.05
10	T/YSC120ED	4800	0.16	0.20	0.18	0.34	0.09	0.35	0.10	—	0.04	0.06

(a) Tested with standard filters. Difference in pressure drop should be considered when utilizing optional 2" MERV 8 and MERV 13 filters.

(b) OA = Outside Air and RA = Return Air.

(c) Nominal kW ratings at 415 volts. Heaters only available on T units.

(d) Electric heaters restricted on applications below 320 cfm/ton.



## Fan Performance

**Table 13. Static pressure drop through accessories (pascals)—5 to 10 tons**

Tons	Unit Model Number	Airflow (m <sup>3</sup> /h)	Standard Filters <sup>(a)</sup>	2" MERV 8 Filter	2" MERV 13 Filter	Economizer with OA/RA Dampers <sup>(b)</sup>				Electric Heater Accessory (kW) <sup>(c),(d)</sup>		
						100% OA	100% RA	100% OA	100% RA	9	13-27	40
						Downflow		Horizontal				
5	WSC060ED	2720	7	15	12	22	2	12	2	2	5	—
5	WSC060ED	3400	12	20	17	27	2	17	5	2	7	—
5	WSC060ED	4080	17	25	25	30	7	22	7	5	10	—
6	WSC072ED	3260	10	17	25	25	2	15	5	—	5	—
6	WSC072ED	4080	15	22	32	27	5	20	5	—	8	—
6	WSC072ED	4890	22	30	37	32	10	25	10	—	13	—
7½	WSC090ED	4080	10	15	30	27	5	20	5	—	5	—
7½	WSC090ED	5100	15	22	32	35	12	30	12	—	8	—
7½	WSC090ED	6120	22	32	37	52	17	62	20	—	11	—
10	WSC120ED	5440	17	25	35	42	12	35	12	—	8	11
10	WSC120ED	6800	27	37	40	65	17	75	20	—	8	13
10	WSC120ED	8160	40	50	45	85	22	87	25	—	9	14

(a) Tested with standard filters. Difference in pressure drop should be considered when utilizing optional 2" MERV 8 and MERV 13 filters.

(b) OA = Outside Air and RA = Return Air.

(c) Nominal kW ratings at 415 volts. Heaters only available on T units.

(d) Electric heaters restricted on applications below 320 cfm/ton.

**Table 14. Static pressure drop through accessories (inches water column)—5 to 10 tons**

Tons	Unit Model Number	cfm	Standard Filters <sup>(a)</sup>	2" MERV 8 Filter	2" MERV 13 Filter	Economizer with OA/RA Dampers <sup>(b)</sup>				Electric Heater Accessory (kW) <sup>(c),(d)</sup>		
						100% OA	100% RA	100% OA	100% RA	9	13-27	40
						Downflow		Horizontal				
5	WSC060ED	1600	0.03	0.06	0.05	0.09	0.01	0.05	0.01	0.01	0.02	—
5	WSC060ED	2000	0.05	0.08	0.07	0.11	0.01	0.07	0.02	0.01	0.03	—
5	WSC060ED	2400	0.07	0.10	0.10	0.12	0.03	0.09	0.03	0.02	0.04	—
6	WSC072ED	1920	0.04	0.07	0.10	0.10	0.01	0.06	0.02	—	0.02	—
6	WSC072ED	2400	0.06	0.09	0.13	0.11	0.02	0.08	0.02	—	0.03	—
6	WSC072ED	2880	0.09	0.12	0.15	0.13	0.04	0.10	0.04	—	0.05	—
7½	WSC090ED	2400	0.04	0.06	0.12	0.11	0.02	0.08	0.02	—	0.02	—
7½	WSC090ED	3000	0.06	0.09	0.13	0.14	0.05	0.12	0.05	—	0.03	—
7½	WSC090ED	3600	0.09	0.13	0.15	0.21	0.07	0.25	0.08	—	0.05	—
10	WSC120ED	3200	0.07	0.10	0.14	0.17	0.05	0.14	0.05	—	0.03	0.05
10	WSC120ED	4000	0.11	0.15	0.16	0.26	0.07	0.30	0.08	—	0.03	0.05
10	WSC120ED	4800	0.16	0.20	0.18	0.34	0.09	0.35	0.10	—	0.04	0.06

(a) Tested with standard filters. Difference in pressure drop should be considered when utilizing optional 2" MERV 8 and MERV 13 filters.

(b) OA = Outside Air and RA = Return Air.

(c) Nominal kW ratings at 415 volts. Heaters only available on T units.

(d) Electric heaters restricted on applications below 320 cfm/ton.



**Table 15. Gas-fired heating capacities for G20, G25 and G31**

Tons	Unit	Furnace	Heating Input		Heating Output	
	Model No.	Model	Input kW	Input MBh	Output kW	Output MBh
5	YSC060EDRL	G80	19.6	67	15.7	54
5	YSC060EDRH	G120	29.3	100	23.4	80
6	YSC072EDRL	G120	29.3	100	23.4	80
6	YSC072EDRH	G200	48.9	167	39.1	134
7½	YSC090EDRL	G120	29.3	100	23.4	80
7½	YSC090EDRH	G200	48.9	167	39.1	134
8½	YSC102EDRL	G150	36.7	125	29.3	100
8½	YSC102EDRH	G250	60.9	208	48.7	166
10	YSC120EDRL	G150	36.7	125	29.3	100
10	YSC120EDRH	G250	60.9	208	48.7	166

**Note:** Ratings shown are for elevations up to 2,000 ft. For higher elevations, reduce ratings at a rate of 4% per 1,000 ft. elevation.

**Table 16. Auxiliary electric heat capacity**

Tons	Unit Model Number	Unit Voltage	Total <sup>(a)</sup>		No. of Stages	Stage1		Stage 2	
			kW Input <sup>(b)</sup>	MBh Output		kW Input	MBh Output	kW Input	MBh Output
5	TSC060ED	380-415/50/3	7.5/9.0	26/31	2	3.75/4.5	13/16	3.75/4.5	13/16
5	TSC060ED	380-415/50/3	10.9/13.0	38/45	2	5.45/6.5	19/23	5.45/6.5	19/23
5	TSC060ED	380-415/50/3	14.4/17.2	50/59	2	8.95/10.7	31/37	5.45/6.5	19/23
6	TSC072ED	380-415/50/3	11.3/13.5	39/47	1	11.3/13.5	39/47	—	—
6	TSC072ED	380-415/50/3	16.9/ 20.2	58/69	2	11.3/13.5	39/47	5.6/6.7	20/23
6	TSC072ED	380-415/50/3	22.6/26.9	78/92	2	11.3/13.5	39/47	11.3/13.5	39/47
7½	TSC090ED	380-415/50/3	11.3/13.5	39/47	1	11.3/13.5	39/47	—	—
7½	TSC090ED	380-415/50/3	16.9/20.2	58/69	2	11.3/13.5	39/47	5.6/6.7	20/23
7½	TSC090ED	380-415/50/3	22.6/26.9	78/92	2	11.3/13.5	39/47	11.3/13.5	39/47
8½	TSC102ED	380-415/50/3	16.9/20.2	58/69	2	11.3/13.5	39/47	5.6/6.7	20/23
8½	TSC102ED	380-415/50/3	22.6/26.9	78/92	2	11.3/13.5	39/47	11.3/13.5	39/47
10	TSC120ED	380-415/50/3	16.9/20.2	58/69	2	11.3/13.5	39/47	5.6/6.7	20/23
10	TSC120ED	380-415/50/3	22.6/26.9	78/92	2	11.3/13.5	39/47	11.3/13.5	39/47
10	TSC120ED	380-415/50/3	33.9/40.4	116/138	2	11.3/13.5	39/47	22.5/26.9	77/92

(a) Heaters are rated at 380/415V. For other than rated voltage, CAP= (voltage/rated voltage)<sup>2</sup> x rated cap.

(b) All input/output does not include indoor fan power or heat.

**Table 17. Auxiliary electric heat capacity**

Tons	Unit Model Number	Unit Voltage	Total <sup>(a)</sup>		No. of Stages	Stage1		Stage 2	
			kW Input <sup>(b)</sup>	MBh Output		kW Input	MBh Output	kW Input	MBh Output
5	WSC060ED	380-415/50/3	7.5/9.0	26/31	2	3.75/4.5	13/16	3.75/4.5	13/16
5	WSC060ED	380-415/50/3	10.9/13.0	38/45	2	5.45/6.5	19/23	5.45/6.5	19/23
5	WSC060ED	380-415/50/3	14.4/17.2	50/59	2	8.95/10.7	31/37	5.45/6.5	19/23
6	WSC072ED	380-415/50/3	11.3/13.5	39/47	1	11.3/13.5	39/47	—	—
6	WSC072ED	380-415/50/3	16.9/20.2	58/69	2	11.3/13.5	39/47	5.6/6.7	20/23
6	WSC072ED	380-415/50/3	22.6/26.9	78/92	2	11.3/13.5	39/47	11.3/13.5	39/47

continued on next page



## Fan Performance

**Table 17. Auxiliary electric heat capacity (continued)**

Tons	Unit Model Number	Unit Voltage	Total <sup>(a)</sup>		No. of Stages	Stage1		Stage 2	
			kW Input <sup>(b)</sup>	MBh Output		kW Input	MBh Output	kW Input	MBh Output
7½	WSC090ED	380-415/50/3	11.3/13.5	39/47	1	11.3/13.5	39/47	—	—
7½	WSC090ED	380-415/50/3	16.9/20.2	58/69	2	11.3/13.5	39/47	5.6/6.7	20/23
7½	WSC090ED	380-415/50/3	22.6/26.9	78/92	2	11.3/13.5	39/47	11.3/13.5	39/47
10	WSC120ED	380-415/50/3	16.9/20.2	58/69	2	11.3/13.5	39/47	5.6/6.7	20/23
10	WSC120ED	380-415/50/3	22.6/26.9	78/92	2	11.3/13.5	39/47	11.3/13.5	39/47
10	WSC120ED	380-415/50/3	33.9/40.4	116/138	2	11.3/13.5	39/47	22.5/26.9	77/92

(a) Does not include fan power or heat.

(b) Heaters are rated at 380/415V. For other than rated voltage, CAP= (voltage/rated voltage)<sup>2</sup> x rated cap.

**Table 18. Electric heater voltage correction factors (applicable to auxiliary heat capacity)**

Nominal Voltage	Distribution Voltage	Capacity Multiplier
415	380	0.84
415	400	0.93
415	415	1.00

**Table 19. Air temperature rise across electric heaters (°C)**

kW	Stages	5 Tons	6 Tons	7½ Tons	8½ Tons	10 Tons
		3400 m <sup>3</sup> /H	4100 m <sup>3</sup> /H	5100 m <sup>3</sup> /H	5800 m <sup>3</sup> /H	6800 m <sup>3</sup> /H
380V/415V		TSC060ED	TSC072ED	TSC072ED	TSC072ED	TSC072ED
07.5/09.0	2	6.6/7.9	—	—	—	—
10.9/13.0	2	9.6/11.4	—	—	—	—
11.3/13.5	1	—	8.3/9.9	6.6/7.9	—	—
14.4/17.2	2	12.6/15.1	—	—	—	—
16.9/20.2	2	—	12.4/14.8	9.9/11.8	8.7/10.4	7.4/8.9
22.6/26.9	2	—	16.5/19.7	13.2/15.7	11.7/13.9	9.9/11.8
33.8/40.4	2	—	—	—	—	14.8/17.7

**Notes:**

1. For minimum design airflow, see airflow performance table for each unit.

2. To calculate temp rise at different airflow, use the following formula: Temp. Rise (C<sup>0</sup>) across Elect Htr= (kW x 2985)/(M<sup>3</sup>/H)

**Table 20. Air temperature rise across electric heaters (°F)**

kW	Stages	5 Tons	6 Tons	7½ Tons	8½ Tons	10 Tons
		2000 m <sup>3</sup> /H	2400 m <sup>3</sup> /H	3000 m <sup>3</sup> /H	3400 m <sup>3</sup> /H	4000 m <sup>3</sup> /H
380V/415V		TSC060ED	TSC072ED	TSC072ED	TSC072ED	TSC072ED
07.5/09.0	2	11.9/14.2	—	—	—	—
10.9/13.0	2	17.2/20.5	—	—	—	—
11.3/13.5	1	—	14.9/17.8	11.9/14.2	—	—
14.4/17.2	2	22.8/27.2	—	—	—	—
16.9/20.2	2	—	22.3/26.6	17.8/21.3	15.7/18.8	13.4/16.0
22.6/26.9	2	—	29.8/35.4	23.8/28.3	21.0/25.0	17.9/21.3
33.8/40.4	2	—	—	—	—	26.7/31.9

**Notes:**

1. For minimum design airflow, see airflow performance table for each unit.

2. To calculate temp rise at different airflow, use the following formula: Temp. Rise (F<sup>0</sup>) across elect htr. = (kW x 3414)/(1.08 x cfm)

**Table 21. Air temperature rise across electric heaters (°C)**

kW	Stages	5 Tons	6 Tons	7½ Tons	10 Tons
		3400 m³/H	4100 m³/H	5100 m³/H	6800 m³/H
380V/415V		WSC060ED	WSC072ED	WSC090ED	WSC120ED
7.5	2	6.6	—	—	—
9.0	2	7.9	—	—	—
10.9	2	9.6	—	—	—
11.3	1	—	8.3	6.6	—
13.0	2	11.4	—	—	—
13.5	1	—	9.9	7.9	—
14.4	2	12.6	—	—	—
16.9	2	—	12.4	9.9	7.4
17.2	2	15.1	—	—	—
20.2	2	—	14.8	11.8	8.9
22.6	2	—	16.5	13.2	9.9
26.9	2	—	19.7	15.7	11.8
33.9	2	—	—	—	14.9
40.4	2	—	—	—	17.7

**Notes:**

1. For minimum design airflow, see airflow performance table for each unit.
2. To calculate temp rise at different airflow, use the following formula: Temp. Rise (C<sup>0</sup>) across Elect Htr = (kW x 2985)/(M<sup>3</sup>/H)

**Table 22. Air temperature rise across electric heaters (°F)**

kW	Stages	5 Tons	6 Tons	7½ Tons	10 Tons
		2000 cfm	2400 cfm	3000 cfm	4000 cfm
380V/415V		WSC060ED	WSC072ED	WSC072ED	WSC072ED
7.5	2	11.9	—	—	—
9.0	2	14.2	—	—	—
10.9	2	17.2	—	—	—
11.3	1	—	14.9	11.9	—
13.0	2	20.5	—	—	—
13.5	1	—	17.8	14.2	—
14.4	2	22.8	—	—	—
16.9	2	—	22.3	17.8	13.4
17.2	2	27.2	—	—	—
20.2	2	—	26.6	21.3	16.0
22.6	2	—	29.8	23.8	17.9
26.9	2	—	35.4	28.3	21.3
33.9	2	—	—	—	26.8
40.4	2	—	—	—	31.9

**Notes:**

1. For minimum design airflow, see airflow performance table for each unit.
2. To calculate temp rise at different airflow, use the following formula: Temp. Rise (F<sup>0</sup>) across Elect Htr = (kW x 3414)/(1.08 x cfm)



# Heating Performance Data

**Table 1. 5 Ton three phase net heating capacities (kW) WSC060ED at 3,400 m<sup>3</sup>/h (SI)**

(C)	Instantaneous Heating Capacity (kW) at Indicated Indoor Dry Bulb (C)				Integrated Heating Capacity (kW) at Indicated Indoor Dry Bulb <sup>(a)</sup> (C)				Total Power in Kilowatts at Indicated Indoor Dry Bulb (C)			
	15	21	24	27	15	21	24	27	15	21	24	27
-24	6.23	5.73	5.47	5.21	5.29	4.87	4.66	4.44	3.65	3.99	4.18	4.38
-21	6.90	6.42	6.17	5.92	5.85	5.45	5.24	5.03	3.70	4.05	4.24	4.45
-18	7.65	7.19	6.95	6.70	6.47	6.09	5.89	5.68	3.75	4.11	4.31	4.52
-15	8.47	8.02	7.78	7.54	7.16	6.78	6.58	6.38	3.81	4.18	4.38	4.59
-12	9.35	8.90	8.66	8.42	7.89	7.51	7.31	7.11	3.86	4.24	4.44	4.66
-9	10.27	9.81	9.57	9.33	8.65	8.27	8.07	7.87	3.91	4.30	4.51	4.73
-6	11.22	10.75	10.51	10.26	9.35	8.96	8.76	8.56	3.98	4.37	4.58	4.80
-3	12.21	11.72	11.47	11.21	10.16	9.76	9.55	9.34	4.03	4.43	4.64	4.87
0	13.22	12.71	12.45	12.18	10.99	10.57	10.36	10.14	4.09	4.49	4.71	4.93
0	14.24	13.72	13.46	13.18	11.84	11.41	11.19	10.96	4.15	4.56	4.77	5.00
6	15.31	14.76	14.48	14.19	12.71	12.26	12.03	11.79	4.21	4.62	4.84	5.07
9	16.40	15.83	15.53	15.23	16.40	15.83	15.53	15.23	4.37	4.80	5.02	5.26
12	17.53	16.92	16.61	16.29	17.53	16.92	16.61	16.29	4.44	4.87	5.10	5.34
15	18.68	18.04	17.71	17.38	18.68	18.04	17.71	17.38	4.51	4.94	5.17	5.41
18	19.87	19.19	18.85	18.50	19.87	19.19	18.85	18.50	4.58	5.02	5.25	5.49
21	21.08	20.37	20.01	19.64	21.08	20.37	20.01	19.64	4.66	5.10	5.33	5.58
24	22.32	21.58	21.20	20.82	22.32	21.58	21.20	20.82	4.74	5.18	5.42	5.66

**Notes:**

1. For other airflow conditions, see heating capacity correction factor [Table 114, p. 122](#).
  2. Net heating capacity and power input includes indoor fan heat at ARI esp. To obtain net heating at other conditions, subtract fan heat at this condition and add fan heat at new condition.
- (a) Integrated heating capacities and powers include the effects of defrost in the frost region. All heating capacities and power (kw) are at 70% OD relative humidity and demand defrost cycle.

## Heating Performance Data

**Table 2. 5 Ton three phase net heating capacities (MBh) WSC060ED at 2,000 cfm (IP)**

(F)	Instantaneous Heating Capacity (MBh) at Indicated Indoor Dry Bulb (F)				Integrated Heating Capacity (MBh) at Indicated Indoor Dry Bulb <sup>(a)</sup> (F)				Total Power in Kilowatts at Indicated Indoor Dry Bulb (F)			
	60	70	75	80	60	70	75	80	60	70	75	80
-8	21.27	19.55	18.67	17.77	18.06	16.63	15.89	15.14	3.65	3.99	4.18	4.38
-3	23.54	21.90	21.06	20.19	19.95	18.59	17.88	17.16	3.70	4.05	4.24	4.45
2	26.11	24.53	23.71	22.87	22.09	20.77	20.09	19.39	3.75	4.11	4.31	4.52
7	28.91	27.36	26.56	25.74	24.42	23.13	22.46	21.78	3.81	4.18	4.38	4.59
12	31.90	30.35	29.56	28.74	26.91	25.62	24.95	24.27	3.86	4.24	4.44	4.66
17	35.04	33.47	32.66	31.84	29.51	28.21	27.54	26.85	3.91	4.30	4.51	4.73
22	38.29	36.69	35.86	35.01	31.90	30.58	29.90	29.20	3.98	4.37	4.58	4.80
27	41.65	39.99	39.13	38.25	34.67	33.29	32.59	31.86	4.03	4.43	4.64	4.87
32	45.11	43.37	42.47	41.56	37.51	36.08	35.34	34.59	4.09	4.49	4.71	4.93
37	48.60	46.83	45.91	44.98	40.39	38.92	38.17	37.40	4.15	4.56	4.77	5.00
42	52.23	50.37	49.41	48.43	43.38	41.84	41.05	40.25	4.21	4.62	4.84	5.07
47	55.97	54.00	52.99	51.96	55.97	54.00	52.99	51.96	4.37	4.80	5.02	5.26
52	59.80	57.73	56.66	55.58	59.80	57.73	56.66	55.58	4.44	4.87	5.10	5.34
57	63.74	61.55	60.44	59.30	63.74	61.55	60.44	59.30	4.51	4.94	5.17	5.41
62	67.78	65.48	64.31	63.11	67.78	65.48	64.31	63.11	4.58	5.02	5.25	5.49
67	71.92	69.51	68.27	67.02	71.92	69.51	68.27	67.02	4.66	5.10	5.33	5.58
72	76.16	73.63	72.34	71.03	76.16	73.63	72.34	71.03	4.74	5.18	5.42	5.66

**Notes:**

1. For other airflow conditions, see heating capacity correction factor [Table 114, p. 122](#).
2. Net heating capacity and power input includes indoor fan heat at ARI esp. To obtain net heating at other conditions, subtract fan heat at this condition and add fan heat at new condition.

(a) Integrated heating capacities and powers include the effects of defrost in the frost region. All heating capacities and power (kw) are at 70% OD relative humidity and demand defrost cycle.



## Heating Performance Data

**Table 3. 6 Ton three phase net heating capacities (kW) WSC072ED at 4,080 m<sup>3</sup>/h (SI)**

(C)	Instantaneous Heating Capacity (kW) at Indicated Indoor Dry Bulb (C)				Integrated Heating Capacity (kW) at Indicated Indoor Dry Bulb <sup>(a)</sup> (C)				Total Power in Kilowatts at Indicated Indoor Dry Bulb (C)			
	15	21	24	27	15	21	24	27	15	21	24	27
-24	7.27	6.93	6.76	6.60	6.82	6.50	6.34	6.19	5.08	5.67	6.00	6.34
-21	8.46	8.09	7.92	7.74	7.93	7.59	7.42	7.26	5.17	5.77	6.10	6.44
-18	9.66	9.26	9.07	8.89	9.05	8.68	8.50	8.33	5.25	5.86	6.19	6.53
-15	10.87	10.45	10.25	10.04	10.18	9.78	9.59	9.40	5.33	5.94	6.27	6.62
-12	12.11	11.66	11.44	11.22	11.33	10.91	10.70	10.50	5.41	6.03	6.36	6.71
-9	13.37	12.89	12.66	12.43	12.51	12.06	11.84	11.63	5.50	6.11	6.45	6.80
-6	14.68	14.16	13.91	13.67	12.72	12.28	12.07	11.86	5.11	5.66	5.96	6.28
-3	16.01	15.47	15.20	14.94	13.88	13.41	13.18	12.95	5.19	5.75	6.05	6.37
0	17.39	16.81	16.53	16.25	15.06	14.56	14.32	14.08	5.28	5.84	6.14	6.46
0	18.82	18.21	17.91	17.62	16.29	15.77	15.51	15.26	5.37	5.93	6.24	6.56
6	20.28	19.64	19.32	19.01	17.55	17.00	16.73	16.46	5.47	6.04	6.35	6.67
9	21.78	21.10	20.77	20.44	21.78	21.10	20.77	20.44	5.64	6.21	6.52	6.84
12	23.32	22.60	22.25	21.91	23.32	22.60	22.25	21.91	5.75	6.32	6.63	6.96
15	24.89	24.14	23.78	23.41	24.89	24.14	23.78	23.41	5.87	6.45	6.76	7.09
18	26.51	25.72	25.34	24.96	26.51	25.72	25.34	24.96	6.00	6.58	6.89	7.22
21	28.16	27.34	26.94	26.54	28.16	27.34	26.94	26.54	6.13	6.71	7.03	7.36
24	29.86	29.01	28.59	28.17	29.86	29.01	28.59	28.17	6.27	6.85	7.17	7.51

**Notes:**

1. For other airflow conditions, see heating capacity correction factor [Table 114, p. 122](#).
2. Net heating capacity and power input includes indoor fan heat at ARI esp. To obtain net heating at other conditions, subtract fan heat at this condition and add fan heat at new condition.

(a) Integrated heating capacities and powers include the effects of defrost in the frost region. All heating capacities and power (kw) are at 70% OD relative humidity and demand defrost cycle.

## Heating Performance Data

**Table 4. 6 Ton three phase net heating capacities (MBh) WSC072ED at 2,400 cfm (IP)**

(F)	Instantaneous Heating Capacity (MBh) at Indicated Indoor Dry Bulb (F)				Integrated Heating Capacity (MBh) at Indicated Indoor Dry Bulb <sup>(a)</sup> (F)				Total Power in Kilowatts at Indicated Indoor Dry Bulb (F)			
	60	70	75	80	60	70	75	80	60	70	75	80
-8	24.81	23.64	23.07	22.52	23.27	22.18	21.65	21.13	5.08	5.67	6.00	6.34
-3	28.88	27.62	27.01	26.41	27.06	25.88	25.32	24.76	5.17	5.77	6.10	6.44
2	32.96	31.61	30.96	30.32	30.87	29.61	29.00	28.41	5.25	5.86	6.19	6.53
7	37.10	35.66	34.96	34.27	34.72	33.38	32.73	32.09	5.33	5.94	6.27	6.62
12	41.32	39.78	39.03	38.30	38.65	37.22	36.52	35.84	5.41	6.03	6.36	6.71
17	45.64	43.99	43.20	42.41	42.68	41.15	40.40	39.67	5.50	6.11	6.45	6.80
22	50.07	48.32	47.47	46.63	43.42	41.91	41.18	40.46	5.11	5.66	5.96	6.28
27	54.64	52.78	51.87	50.97	47.35	45.74	44.96	44.19	5.19	5.75	6.05	6.37
32	59.33	57.36	56.39	55.44	51.39	49.69	48.86	48.04	5.28	5.84	6.14	6.46
37	64.22	62.14	61.12	60.12	55.60	53.81	52.93	52.07	5.37	5.93	6.24	6.56
42	69.20	67.01	65.93	64.87	59.89	58.00	57.07	56.16	5.47	6.04	6.35	6.67
47	74.31	72.00	70.87	69.74	74.31	72.00	70.87	69.74	5.64	6.21	6.52	6.84
52	79.56	77.13	75.93	74.75	79.56	77.13	75.93	74.75	5.75	6.32	6.63	6.96
57	84.94	82.38	81.13	79.89	84.94	82.38	81.13	79.89	5.87	6.45	6.76	7.09
62	90.45	87.78	86.46	85.16	90.45	87.78	86.46	85.16	6.00	6.58	6.89	7.22
67	96.10	93.30	91.93	90.56	96.10	93.30	91.93	90.56	6.13	6.71	7.03	7.36
72	101.89	98.97	97.54	96.11	101.89	98.97	97.54	96.11	6.27	6.85	7.17	7.51

**Notes:**

1. For other airflow conditions, see heating capacity correction factor [Table 114, p. 122](#).
2. Net heating capacity and power input includes indoor fan heat at ARI esp. To obtain net heating at other conditions, subtract fan heat at this condition and add fan heat at new condition.

(a) Integrated heating capacities and powers include the effects of defrost in the frost region. All heating capacities and power (kw) are at 70% OD relative humidity and demand defrost cycle.



## Heating Performance Data

**Table 5. 7½ Ton three phase net heating capacities (kW) WSC072ED at 5,100 m<sup>3</sup>/h (SI)**

(C)	Instantaneous Heating Capacity (kW) at Indicated Indoor Dry Bulb (C)				Integrated Heating Capacity (kW) at Indicated Indoor Dry Bulb <sup>(a)</sup> (C)				Total Power in Kilowatts at Indicated Indoor Dry Bulb (C)			
	15	21	24	27	15	21	24	27	15	21	24	27
-24	10.16	9.74	9.49	9.21	8.85	8.49	8.28	8.04	5.65	6.18	6.47	6.77
-21	11.57	11.16	10.92	10.65	10.05	9.70	9.50	9.27	5.77	6.31	6.60	6.91
-18	12.96	12.56	12.32	12.06	11.24	10.90	10.70	10.47	5.88	6.43	6.73	7.04
-15	14.37	13.96	13.72	13.45	12.45	12.10	11.89	11.67	5.99	6.54	6.84	7.15
-12	15.81	15.39	15.14	14.86	13.68	13.32	13.10	12.87	6.09	6.65	6.95	7.26
-9	17.30	16.85	16.58	16.29	14.95	14.57	14.34	14.09	6.18	6.75	7.05	7.36
-6	18.84	18.35	18.06	17.75	14.40	14.03	13.82	13.58	6.10	6.66	6.96	7.28
-3	20.43	19.89	19.57	19.24	15.59	15.18	14.95	14.70	6.19	6.75	7.06	7.37
0	22.07	21.46	21.12	20.75	16.82	16.36	16.11	15.83	6.28	6.85	7.15	7.47
0	23.72	23.07	22.71	22.33	18.05	17.57	17.30	17.01	6.38	6.95	7.26	7.58
6	25.42	24.71	24.32	23.90	19.33	18.80	18.50	18.19	6.49	7.06	7.37	7.69
9	27.16	26.38	25.95	25.49	27.16	26.38	25.95	25.49	6.75	7.33	7.64	7.96
12	28.92	28.06	27.59	27.10	28.92	28.06	27.59	27.10	6.88	7.45	7.76	8.08
15	30.69	29.76	29.25	28.72	30.69	29.76	29.25	28.72	7.01	7.59	7.90	8.22
18	32.48	31.47	30.92	30.35	32.48	31.47	30.92	30.35	7.16	7.74	8.05	8.37
21	34.29	33.19	32.61	32.00	34.29	33.19	32.61	32.00	7.32	7.90	8.21	8.54
24	36.11	34.94	34.32	33.67	36.11	34.94	34.32	33.67	7.49	8.07	8.39	8.71

**Notes:**

1. For other airflow conditions, see heating capacity correction factor [Table 114, p. 122](#).
2. Net heating capacity and power input includes indoor fan heat at ARI esp. To obtain net heating at other conditions, subtract fan heat at this condition and add fan heat at new condition.

(a) Integrated heating capacities and powers include the effects of defrost in the frost region. All heating capacities and power (kw) are at 70% OD relative humidity and demand defrost cycle.



## Heating Performance Data

**Table 6. 7½ Ton three phase net heating capacities (MBh) WSC090ED at 3,000 cfm (IP)**

(F)	Instantaneous Heating Capacity (MBh) at Indicated Indoor Dry Bulb (F)				Integrated Heating Capacity (MBh) at Indicated Indoor Dry Bulb <sup>(a)</sup> (F)				Total Power in Kilowatts at Indicated Indoor Dry Bulb (F)			
	60	70	75	80	60	70	75	80	60	70	75	80
-8	34.68	33.22	32.37	31.42	30.21	28.97	28.24	27.43	5.65	6.18	6.47	6.77
-3	39.46	38.07	37.24	36.33	34.30	33.11	32.40	31.62	5.77	6.31	6.60	6.91
2	44.22	42.85	42.04	41.13	38.36	37.19	36.50	35.73	5.88	6.43	6.73	7.04
7	49.02	47.64	46.82	45.91	42.47	41.28	40.58	39.81	5.99	6.54	6.84	7.15
12	53.95	52.50	51.65	50.71	46.67	45.44	44.71	43.91	6.09	6.65	6.95	7.26
17	59.03	57.49	56.58	55.59	51.02	49.70	48.93	48.08	6.18	6.75	7.05	7.36
22	64.29	62.60	61.63	60.57	49.14	47.88	47.15	46.35	6.10	6.66	6.96	7.28
27	69.72	67.86	66.79	65.64	53.20	51.81	51.01	50.15	6.19	6.75	7.06	7.37
32	75.30	73.22	72.06	70.81	57.38	55.83	54.95	54.02	6.28	6.85	7.15	7.47
37	80.93	78.73	77.49	76.18	61.59	59.94	59.02	58.04	6.38	6.95	7.26	7.58
42	86.75	84.32	82.98	81.55	65.95	64.14	63.13	62.06	6.49	7.06	7.37	7.69
47	92.67	90.00	88.54	86.98	92.67	90.00	88.54	86.98	6.75	7.33	7.64	7.96
52	98.67	95.74	94.15	92.46	98.67	95.74	94.15	92.46	6.88	7.45	7.76	8.08
57	104.73	101.53	99.80	97.99	104.73	101.53	99.80	97.99	7.01	7.59	7.90	8.22
62	110.83	107.37	105.51	103.56	110.83	107.37	105.51	103.56	7.16	7.74	8.05	8.37
67	117.00	113.26	111.26	109.18	117.00	113.26	111.26	109.18	7.32	7.90	8.21	8.54
72	123.23	119.22	117.09	114.87	123.23	119.22	117.09	114.87	7.49	8.07	8.39	8.71

**Notes:**

1. For other airflow conditions, see heating capacity correction factor [Table 114, p. 122](#).
2. Net heating capacity and power input includes indoor fan heat at ARI esp. To obtain net heating at other conditions, subtract fan heat at this condition and add fan heat at new condition.

(a) Integrated heating capacities and powers include the effects of defrost in the frost region. All heating capacities and power (kw) are at 70% OD relative humidity and demand defrost cycle.



## Heating Performance Data

**Table 7. 10 Ton three phase net heating capacities (kW) WSC072ED at 6,800 m<sup>3</sup>/h (SI)**

(C)	Instantaneous Heating Capacity (kW) at Indicated Indoor Dry Bulb (C)				Integrated Heating Capacity (kW) at Indicated Indoor Dry Bulb <sup>(a)</sup> (C)				Total Power in Kilowatts at Indicated Indoor Dry Bulb (C)			
	15	21	24	27	15	21	24	27	15	21	24	27
-24	13.15	11.93	11.29	10.64	10.82	9.84	9.34	8.82	7.17	7.79	8.13	8.49
-21	15.01	13.93	13.37	12.80	12.30	11.44	11.00	10.54	7.29	7.93	8.27	8.65
-18	16.76	15.81	15.31	14.79	13.70	12.94	12.54	12.13	7.39	8.05	8.41	8.79
-15	18.50	17.63	17.17	16.70	15.09	14.39	14.03	13.65	7.50	8.17	8.53	8.92
-12	20.27	19.45	19.01	18.57	16.50	15.84	15.50	15.14	7.60	8.28	8.65	9.05
-9	22.11	21.31	20.88	20.44	17.97	17.33	16.99	16.64	7.70	8.40	8.78	9.18
-6	24.05	23.23	22.80	22.35	16.93	16.38	16.08	15.78	7.70	8.40	8.77	9.17
-3	26.09	25.23	24.77	24.30	18.33	17.74	17.43	17.11	7.81	8.52	8.90	9.30
0	28.21	27.28	26.79	26.29	19.77	19.14	18.81	18.46	7.94	8.65	9.03	9.44
0	30.29	29.36	28.86	28.36	21.19	20.55	20.22	19.87	8.06	8.78	9.17	9.58
6	32.53	31.51	30.98	30.43	22.72	22.03	21.66	21.29	8.19	8.92	9.31	9.73
9	34.82	33.70	33.12	32.53	34.82	33.70	33.12	32.53	8.60	9.36	9.78	10.21
12	37.15	35.92	35.28	34.63	37.15	35.92	35.28	34.63	8.75	9.52	9.94	10.37
15	39.49	38.15	37.45	36.74	39.49	38.15	37.45	36.74	8.91	9.68	10.10	10.54
18	41.85	40.38	39.63	38.86	41.85	40.38	39.63	38.86	9.07	9.85	10.27	10.71
21	44.21	42.63	41.81	40.99	44.21	42.63	41.81	40.99	9.24	10.03	10.45	10.89
24	46.59	44.89	44.02	43.13	46.59	44.89	44.02	43.13	9.42	10.21	10.63	11.08

**Notes:**

1. For other airflow conditions, see heating capacity correction factor [Table 114, p. 122](#).
2. Net heating capacity and power input includes indoor fan heat at ARI esp. To obtain net heating at other conditions, subtract fan heat at this condition and add fan heat at new condition.

(a) Integrated heating capacities and powers include the effects of defrost in the frost region. All heating capacities and power (kw) are at 70% OD relative humidity and demand defrost cycle.

## Heating Performance Data

**Table 8. 10 Ton three phase net heating capacities (MBh) WSC120ED at 4,000 cfm (IP)**

(F)	Instantaneous Heating Capacity (MBh) at Indicated Indoor Dry Bulb (F)				Integrated Heating Capacity (MBh) at Indicated Indoor Dry Bulb <sup>(a)</sup> (F)				Total Power in Kilowatts at Indicated Indoor Dry Bulb (F)			
	60	70	75	80	60	70	75	80	60	70	75	80
-8	44.88	40.69	38.53	36.31	36.92	33.59	31.86	30.08	7.17	7.79	8.13	8.49
-3	51.20	47.53	45.62	43.66	41.97	39.04	37.52	35.95	7.29	7.93	8.27	8.65
2	57.20	53.94	52.23	50.47	46.75	44.15	42.79	41.39	7.39	8.05	8.41	8.79
7	63.11	60.14	58.58	56.97	51.47	49.10	47.86	46.57	7.50	8.17	8.53	8.92
12	69.15	66.35	64.88	63.35	56.29	54.06	52.88	51.66	7.60	8.28	8.65	9.05
17	75.45	72.70	71.26	69.76	61.31	59.12	57.97	56.78	7.70	8.40	8.78	9.18
22	82.07	79.28	77.80	76.28	57.78	55.87	54.87	53.83	7.70	8.40	8.77	9.17
27	89.03	86.08	84.53	82.93	62.54	60.52	59.46	58.37	7.81	8.52	8.90	9.30
32	96.26	93.09	91.42	89.71	67.47	65.30	64.17	63.00	7.94	8.65	9.03	9.44
37	103.36	100.16	98.49	96.76	72.32	70.13	68.99	67.81	8.06	8.78	9.17	9.58
42	111.00	107.52	105.70	103.84	77.54	75.16	73.92	72.64	8.19	8.92	9.31	9.73
47	118.82	115.00	113.02	110.98	118.82	115.00	113.02	110.98	8.60	9.36	9.78	10.21
52	126.75	122.56	120.39	118.16	126.75	122.56	120.39	118.16	8.75	9.52	9.94	10.37
57	134.74	130.16	127.79	125.37	134.74	130.16	127.79	125.37	8.91	9.68	10.10	10.54
62	142.78	137.79	135.21	132.59	142.78	137.79	135.21	132.59	9.07	9.85	10.27	10.71
67	150.85	145.45	142.67	139.85	150.85	145.45	142.67	139.85	9.24	10.03	10.45	10.89
72	158.97	153.17	150.19	147.17	158.97	153.17	150.19	147.17	9.42	10.21	10.63	11.08

**Notes:**

1. For other airflow conditions, see heating capacity correction factor [Table 114, p. 122](#).
2. Net heating capacity and power input includes indoor fan heat at ARI esp. To obtain net heating at other conditions, subtract fan heat at this condition and add fan heat at new condition.

(a) Integrated heating capacities and powers include the effects of defrost in the frost region. All heating capacities and power (kw) are at 70% OD relative humidity and demand defrost cycle.



# Controls

## ReliaTel™ Controlled Units

Zone sensors are the building occupant's comfort control devices. The following zone sensor options are available for Precedent™ units with ReliaTel control:

### Differential Enthalpy

Differential enthalpy replaces the standard dry bulb control with two enthalpy sensors that compare total heat content of the indoor air and outdoor air to determine the most efficient air source. This control option offers the highest level of comfort control, plus energy efficiency, available.

### Differential Pressure Switches

The factory-installed or field-installed option allows individual fan failure and dirty filter indication. The fan failure switch will disable all unit functions and "flash" the Service LED on the zone sensor. The dirty filter switch will light the Service LED on the zone sensor and allow continued unit operation.

### Manual Changeover

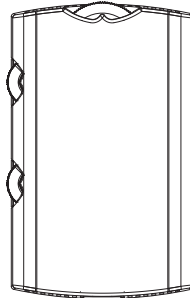

Heat, Cool, or Off system switch. Fan Auto or Off switch. One temperature setpoint lever.

### Manual/Automatic Changeover

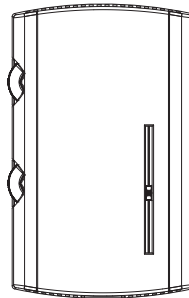

Auto, Heat, Cool, or Off system switch. Fan Auto or Off switch. Two temperature setpoint levers.

### Manual/Automatic Changeover

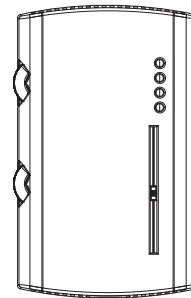

Auto, Heat, Cool, or Off system switch. Fan Auto or Off switch. Two temperature setpoint levers. Status indication LED lights, System On, Heat, Cool, or Service.

**Manual/Automatic Changeover**

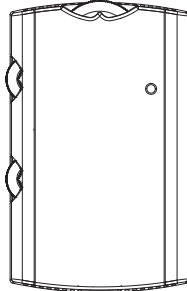

Auto, Heat, Cool, or Off system switch. Fan Auto or Off switch. Two temperature setpoint levers.

**Remote Sensor**

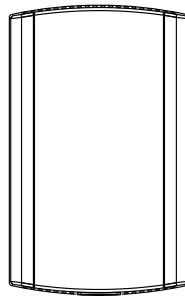

Sensor(s) available for all zone sensors to provide remote sensing capabilities.

**Integrated Comfort™ System**

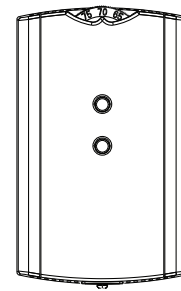

Sensor(s) available with optional temperature adjustment and override buttons to provide central control through a Trane Integrated Comfort™ system.

**Digital Display Programmable Thermostat (1H/1C)**

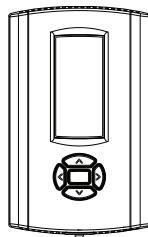

One heat/One Cool Auto changeover digital display thermostat.

**Digital Display Thermostat (3H/2C)**

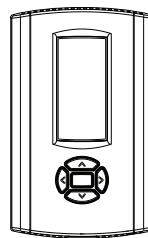

Three Heat, Two Cool Auto changeover digital display thermostat.

**Digital Display Programmable Thermostat (3H/2C)**

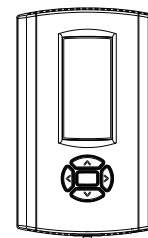

Three Heat/Two Cool Auto changeover digital display thermostat. Seven-day programmable stat with night setback is available.

**Programmable Night Setback**

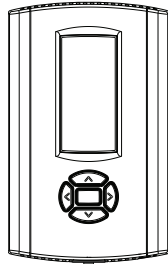

Auto or manual changeover with seven-day programming. Keyboard selection of Heat, Cool, Fan, Auto, or On. All programmable sensors have System On, Heat, Cool, Service LED/indicators as standard. Night Setback Sensors have one Occupied, one Unoccupied, and one Override program per day.

**Wireless Zone Sensor**

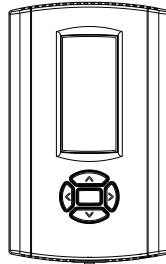

LCD display that provides heat, cool, auto or off. Includes two temperature setpoints and a lockable setting with °F or °C indicators.

**CO<sub>2</sub> Sensing**

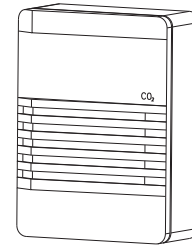

The CO<sub>2</sub> sensor shall have the ability to monitor the concentration (parts per million, ppm) of CO<sub>2</sub> (Carbon Dioxide) in the air. As the CO<sub>2</sub> concentration changes, the outside air damper modulates to meet the current ventilation needs of the zone.

**Touchscreen Programmable Thermostat (2H/2C)**

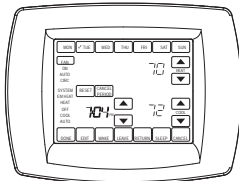

Two Heat/Two Cool programmable thermostat with touch screen digital display. Menu-driven programming. Effortless set-up. Program each day separately with no need to copy multiple days. All programming can be done on one screen. Easy to read and use. Large, clear backlit digital display.

**Digital Display Programmable Thermostat with Built-In Relative Humidity Sensing (3H/2C)**

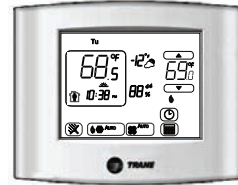

Three Heat, Two Cool digital display thermostat with built-in humidity control and display. This thermostat combines both humidity and dry bulb into one.

Not compatible with VAV units.

**Economizer Controls**

The standard equipment offering is a fixed dry bulb changeover control. In addition, there are two optional controls, Enthalpy and Differential Enthalpy Control.

**Enthalpy Control**

Replaces the dry bulb control with a wet bulb changeover controller which has a fully adjustable setpoint. Enthalpy control offers a higher level of comfort control, along with energy savings potential, than the standard dry bulb control. This is due to the additional wet bulb sensing capability.

**RA Remote Sensor**

Return Air Remote Sensor, which can be mounted in the return air duct to report return air temperature.

**Room Remote Sensor**

Space Remote Sensor, which can be mounted on the wall to report/control from a remote location in the space.

**Remote Potentiometer**

Minimum position setting of economizer can be remotely adjusted with this accessory.

**Trane® Communication Interface (TCI)**

This factory-installed or field-installed micro-processor interface allows the unit to communicate to Trane's Integrated Comfort™ system.



# Electrical Data

**Table 1. Unit wiring—standard efficiency**

Tons	Unit Model Number	Voltage Range	Standard Indoor Fan Motor <sup>(a)</sup>		Oversized Indoor Fan Motor	
			MCA	Max Fuse Size or Max Circuit Breaker	MCA	Max Fuse Size or Max Circuit Breaker
5	T/YSC060ED	342 - 456	17.8/17.9	25/25	—/—	—/—
6	T/YSC072ED	342 - 456	24.8/24.9	35/35	—/—	—/—
7½	T/YSC090ED	342 - 456	28.8/28.6	45/45	28.7/28.8	45/45
8½	T/YSC102ED	342 - 456	30.8/30.6	40/40	30.7/30.8	40/40
10	T/YSC120ED	342 - 456	30.8/30.9	40/40	—/—	—/—

(a) Ratings @380/415V.

**Table 2. Unit wiring—standard efficiency**

Tons	Unit Model Number	Voltage Range	Standard Indoor Fan Motor <sup>(a)</sup>		Oversized Indoor Fan Motor	
			MCA	Max Fuse Size or Max Circuit Breaker	MCA	Max Fuse Size or Max Circuit Breaker
5	WSC060ED	342 - 456	17.8/17.9	25/25	—/—	—/—
6	WSC072ED	342 - 456	21.7/21.8	30/30	—/—	—/—
7½	WSC090ED	342 - 456	28.8/28.6	45/45	28.7/28.8	45/45
10	WSC120ED	342 - 456	31.7/31.8	40/40	—/—	—/—

(a) Ratings @380/415V.

**Table 3. Unit wiring with electric heat (single point connection)—standard efficiency**

Tons	Unit Model Number	Heater Model Number	Heater		Control Stages	Standard Indoor Motor		Oversized Indoor Motor	
			kW Rating <sup>(a)</sup>	MBh <sup>(a)</sup>		MCA <sup>(a)</sup>	Max Fuse Size or Max Circuit Breaker <sup>(a)</sup>	MCA <sup>(a)</sup>	Max Fuse Size or Max Circuit Breaker <sup>(a)</sup>
<b>380/415 Volts Three Phase</b>									
5	TSC060ED	BAYHTRR412B	7.5/9.0	26/31	2	18.6/20.1	25/25	—/—	—/—
5	TSC060ED	BAYHTRR418B	10.9/13.0	38/45	2	25.1/27.1	30/30	—/—	—/—
5	TSC060ED	BAYHTRR423B	14.4/17.2	50/59	2	31.8/34.4	35/35	—/—	—/—
6	TSC072ED	BAYHTRS418B	11.3/13.5	39/47	1	25.9/28.0	35/35	—/—	—/—
6	TSC072ED	BAYHTRS427B	16.9/20.2	58/69	2	36.5/39.6	40/40	—/—	—/—
6	TSC072ED	BAYHTRS436B	22.6/26.9	78/92	2	47.3/51.3	50/60	—/—	—/—
7½	TSC090ED	BAYHTRS418B	11.3/13.5	39/47	1	28.8/29.5	45/45	28.7/29.8	45/45
7½	TSC090ED	BAYHTRS427B	16.9/20.2	58/69	2	38.4/41.1	45/45	38.3/41.4	45/45
7½	TSC090ED	BAYHTRS436B	22.6/26.9	78/92	2	49.1/52.8	50/60	49.0/53.0	50/60
8½	TSC102ED	BAYHTRT427B	16.9/20.2	58/69	2	38.4/41.1	40/45	38.3/41.4	40/45
8½	TSC102ED	BAYHTRT436B	22.6/26.9	78/92	2	49.1/52.8	50/60	49.0/53.0	50/60
10	TSC120ED	BAYHTRT427B	16.9/20.2	58/69	2	38.3/41.4	40/45	—/—	—/—
10	TSC120ED	BAYHTRT436B	22.6/26.9	78/92	2	49.0/53.0	50/60	—/—	—/—
10	TSC120ED	BAYHTRT454B	33.9/40.4	116/138	2	70.4/76.5	80/80	—/—	—/—

(a) Rating @380/415 volt.



**Table 4. Unit wiring with electric heat (single point connection)—standard efficiency**

Tons	Unit Model Number	Heater Model Number	Heater		Control Stages	Standard Indoor Motor		Oversized Indoor Motor	
			kW Rating <sup>(a)</sup>	MBh <sup>(a)</sup>		MCA <sup>(a)</sup>	Max Fuse Size or Max Circuit Breaker <sup>(a)</sup>	MCA <sup>(a)</sup>	Max Fuse Size or Max Circuit Breaker <sup>(a)</sup>
<b>380/415 Volts Three Phase</b>									
5	WSC060ED	BAYHTRR412B	7.5/9.0	26/31	2	32.0/33.5	35/40	—/—	—/—
5	WSC060ED	BAYHTRR418B	10.9/13.0	38/45	2	38.5/40.5	45/45	—/—	—/—
5	WSC060ED	BAYHTRR423B	14.4/17.2	50/59	2	45.1/47.7	50/50	—/—	—/—
6	WSC072ED	BAYHTRS418B	11.3/13.5	39/47	1	43.2/45.3	50/50	—/—	—/—
6	WSC072ED	BAYHTRS427B	16.9/20.2	58/69	2	53.8/56.9	60/60	—/—	—/—
6	WSC072ED	BAYHTRS436B	22.6/26.9	78/92	2	64.5/68.5	70/70	—/—	—/—
7½	WSC090ED	BAYHTRS418B	11.3/13.5	39/47	1	50.3/52.1	60/60	50.2/52.3	60/60
7½	WSC090ED	BAYHTRS427B	16.9/20.2	58/69	2	60.9/63.7	70/70	60.8/63.9	70/70
7½	WSC090ED	BAYHTRS436B	22.6/26.9	78/92	2	71.7/75.3	80/80	71.6/75.5	80/80
10	WSC120ED	BAYHTRT427B	16.9/20.2	58/69	2	63.8/66.9	70/70	—/—	—/—
10	WSC120ED	BAYHTRT436B	22.6/26.9	78/92	2	74.5/78.5	80/80	—/—	—/—
10	WSC120ED	BAYHTRT454B	33.9/40.4	116/138	2	95.9/102.0	100/110	—/—	—/—

(a) Rating @380/415 volt.

**Table 5. Electrical characteristics—compressor motor and condenser motor—50 cycle—standard efficiency**

Tons	Unit Model Number	No.	Compressor Motors						Condenser Fan Motors					
			Volts	Phase	hp Cir 1/Cir 2	rpm Cir 1/Cir 2	Amps		Volts	Phase	hp	Amps		
							RLA Cir 1/Cir 2	LRA Cir 1/Cir 2				FLA	LRA	
5	T/YSC060ED	1	380 - 420	3	4.8	2900	10.6	67-74	1	380 - 415	1	0.40	1.0	2.1
6	T/YSC072ED	1	380 - 420	3	6.5	2900	14.7	86-95	1	380 - 415	1	0.75	2.9	7.1
7½	T/YSC090ED	1	380 - 420	3	7.3	2900	16.7	100-111	1	380 - 415	1	0.75	2.9	7.1
8½	T/YSC102ED	2	380 - 420	3	4.8/3.6	2900/2900	10.6/9.6	67-74/58-64	1	380 - 415	1	0.75	2.9	7.1
10	T/YSC120ED	2	380 - 420	3	5.2/3.9	2900/2900	11.2/9.0	68-75/58-64	1	380 - 415	1	0.75	2.9	7.1
5	WSC060ED	1	380 - 420	3	4.8	2900	10.6	67-74	1	380 - 415	1	0.40	1.0	2.1
6	WSC072ED	1	380 - 420	3	5.9	2900	12.2	91-101	1	380 - 415	1	0.75	2.9	7.1
7½	WSC090ED	1	380 - 420	3	7.3	2900	16.7	100-111	1	380 - 415	1	0.75	2.9	7.1
10	WSC120ED	2	380 - 420	3	4.8/4.8	2900/2900	10.6/10.6	67-74/67-74	1	380 - 415	1	0.75	2.9	7.1

**Table 6. Electrical characteristics—standard evaporator fan motor—50 cycle—belt drive—standard efficiency**

Tons	Unit Model Number	Drive	No.	Motor Voltage	Motor Hz	Motor Phase	hp	Amps	
								FLA	LRA
5	T/YSC060ED	Belt Drive	1	380 - 415	50	3	1.5	3.5 - 3.6	22.6 - 25.3
6	T/YSC072ED	Belt Drive	1	380 - 415	50	3	1.5	3.5 - 3.6	22.6 - 25.3
7½	T/YSC090ED	Belt Drive	1	380 - 415	50	3	2.0	5.0 - 4.8	23.7 - 26.1
8½	T/YSC102ED	Belt Drive	1	380 - 415	50	3	2.0	5.0 - 4.8	23.7 - 26.1
10	T/YSC120ED	Belt Drive	1	380 - 415	50	3	3.0	4.9 - 5.0	48.0 - 57.0
5	WSC060ED	Belt Drive	1	380 - 415	50	3	1.5	3.5 - 3.6	22.6 - 25.3
6	WSC072ED	Belt Drive	1	380 - 415	50	3	1.5	3.5 - 3.6	22.6 - 25.3
7½	WSC090ED	Belt Drive	1	380 - 415	50	3	2.0	5.0 - 4.8	23.7 - 26.1
10	WSC120ED	Belt Drive	1	380 - 415	50	3	3.0	4.9 - 5.0	48.0 - 57.0



## Electrical Data

**Table 7. Electrical characteristics—oversize evaporator fan motor—50 cycle—belt drive—standard efficiency**

Tons	Unit Model Number	Drive	No.	Motor Voltage	Motor Hz	Motor Phase	hp	Amps	
								FLA	LRA
7½	T/YSC090ED	Belt Drive	1	380 - 415	50	3	3.0	4.9 - 5.0	48.0 - 57.0
8½	T/YSC102ED	Belt Drive	1	380 - 415	50	3	3.0	4.9 - 5.0	48.0 - 57.0
7½	WSC090ED	Belt Drive	1	380 - 415	50	3	3.0	4.9 - 5.0	48.0 - 57.0

**Table 8. Electrical characteristics—inducer motor**

Unit Model Number	Stages	hp	rpm	Volts	Phase	FLA
YSC(060-090)ED*(L) YSC060ED*(H)	1	1/35	2500	208-230	1	0.6
YSC(072-090)ED*(H) YSC(102-120)ED*(L,H)	2	1/15	2800	208-230	1	0.5

# Jobsite Connections

**Table 1. Typical Number of Wires**

Zone Sensors		
A	Manual Changeover .....	4
	Manual/Auto Changeover .....	5
	Manual/Auto Changeover with Status Indication LEDs .....	10
	Programmable Night Setback with Status Indication LEDs .....	7
Thermostats		
A	3 Wires, 24V, Cooling only	
	4 Wires, 24V, with Electric Heat	
B	3 Power Wires + 1 Ground Wire (3-phase)	
	2 Power Wires + 1 Ground Wire (1-phase)	

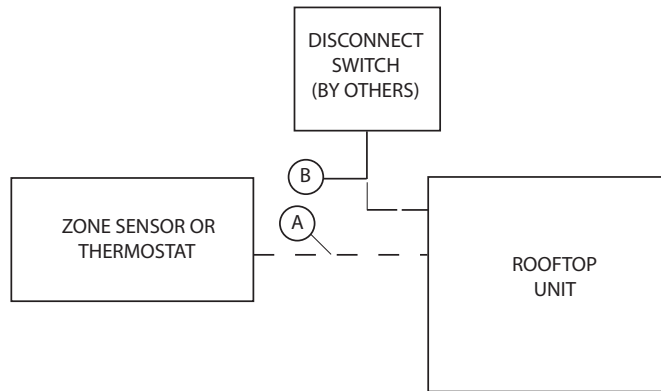

**Notes:**

- For specific wiring information, see the installation instructions.
- All wiring except power wire is low voltage.
- All customer-supplied wiring to be copper and must conform to applicable electrical codes (such as NEC or CEC) and local electric codes. Wiring shown dotted is to be furnished and installed by the customer.

# Dimensional Data

**Figure 1. Cooling and gas/electric—5 tons standard efficiency**

**Notes:**

1. All dimensions are in inches/millimeters.
2. 1/2 NPT Gas Connection = (Y\_C Models only)

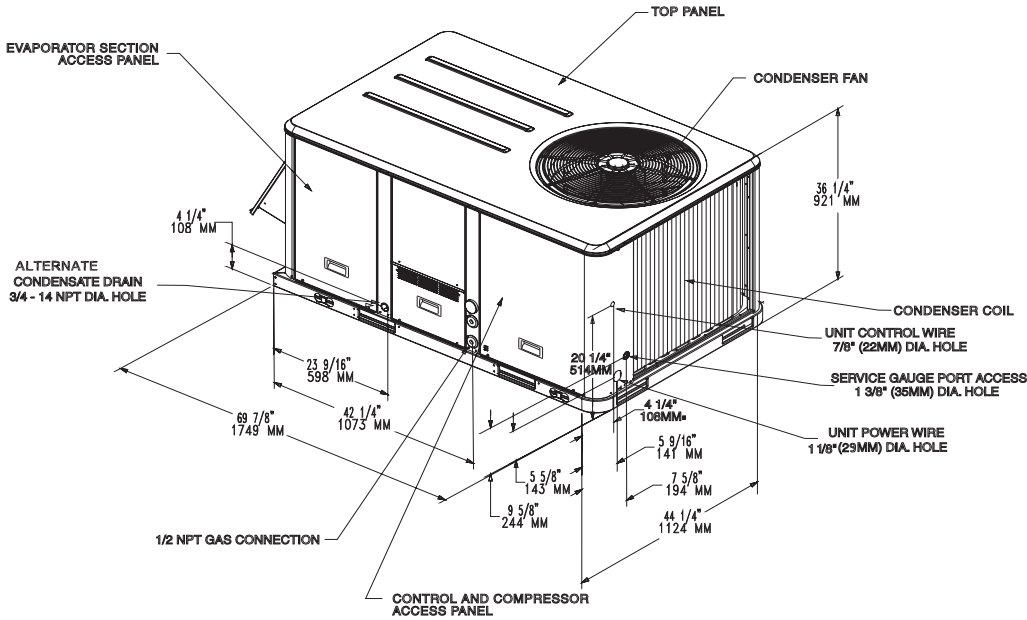

**Figure 2. Heat pumps—5 tons standard efficiency**

**Notes:**

1. All dimensions are in inches/millimeters.

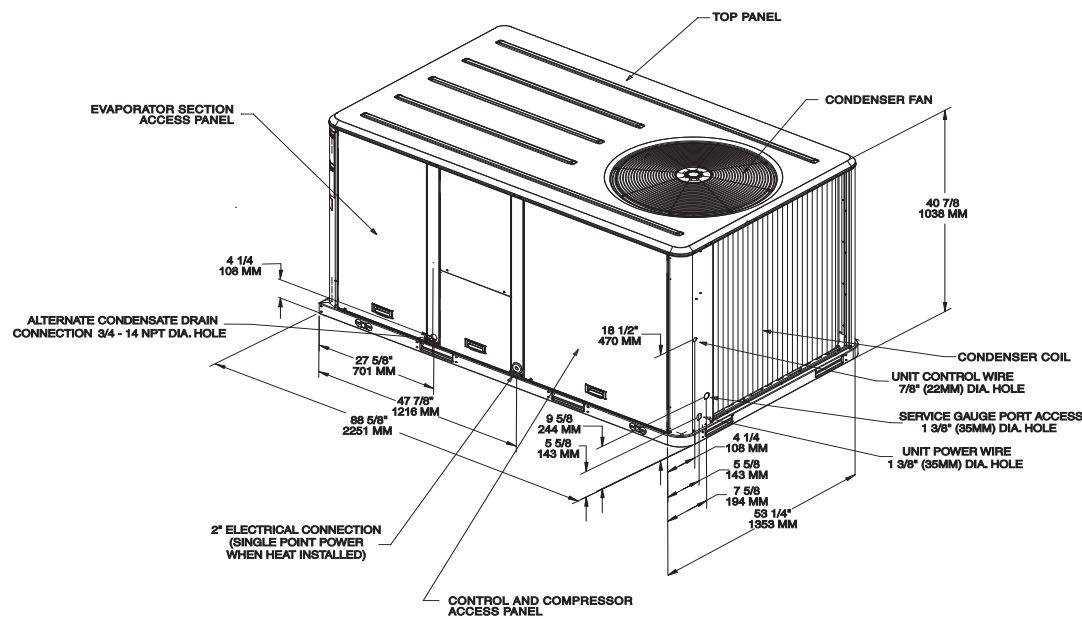

**Figure 3. Cooling, gas/electric and heat pump—5 tons standard efficiency—downflow airflow supply/return through the base utilities**

**Note:** All dimensions are in inches/millimeters.

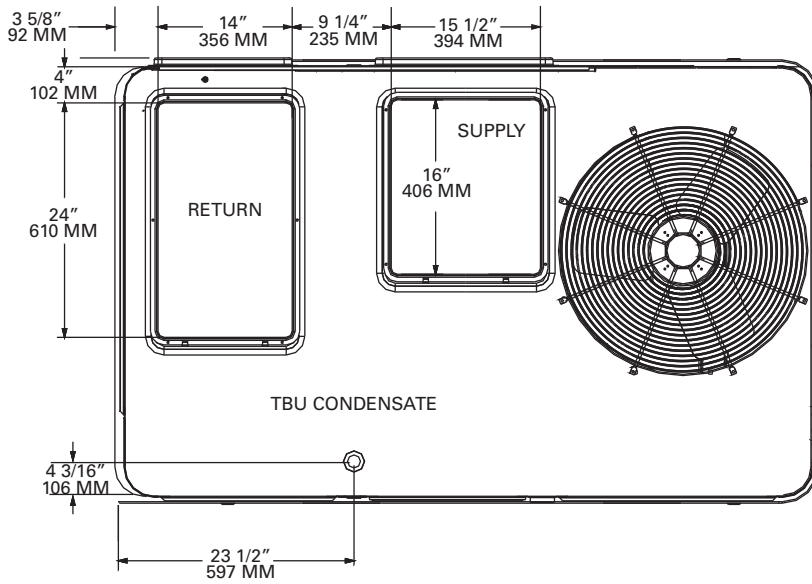

**Figure 4. Cooling, gas/electric and heat pump—5 tons standard efficiency—horizontal airflow supply/return**

**Note:** All dimensions are in inches/millimeters.

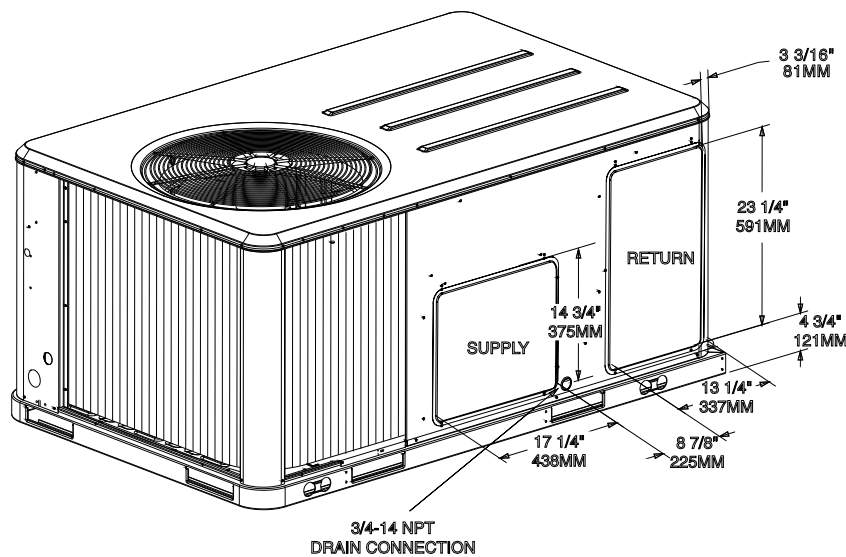

## Dimensional Data

**Figure 5. Cooling, gas/electric and heat pump—5 tons standard efficiency—unit clearance and roof opening**

Note: All dimensions are in inches/millimeters.

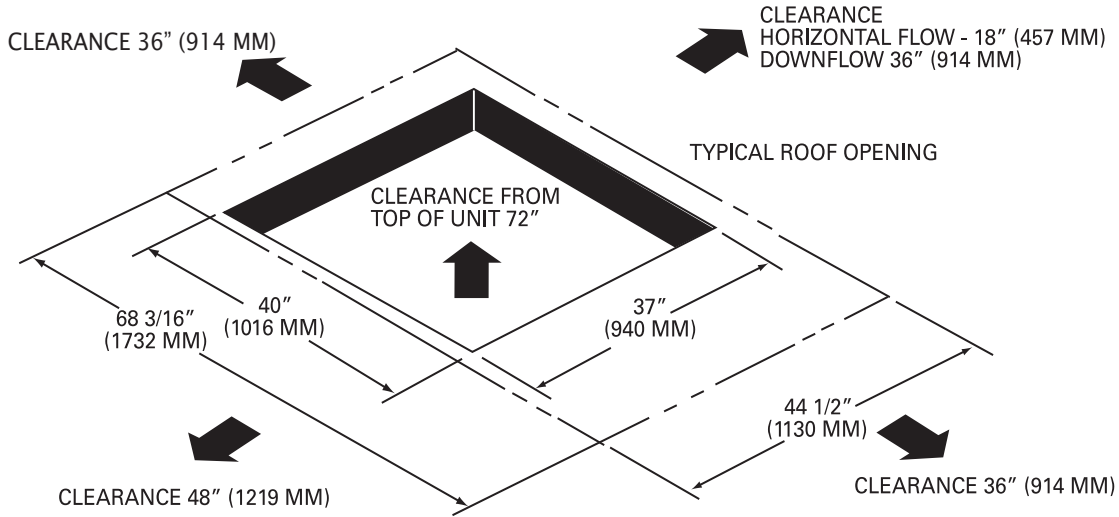

**Figure 6. Cooling, gas/electric and heat pump—5 tons standard efficiency—roof curb**

Note: All dimensions are in inches/millimeters.

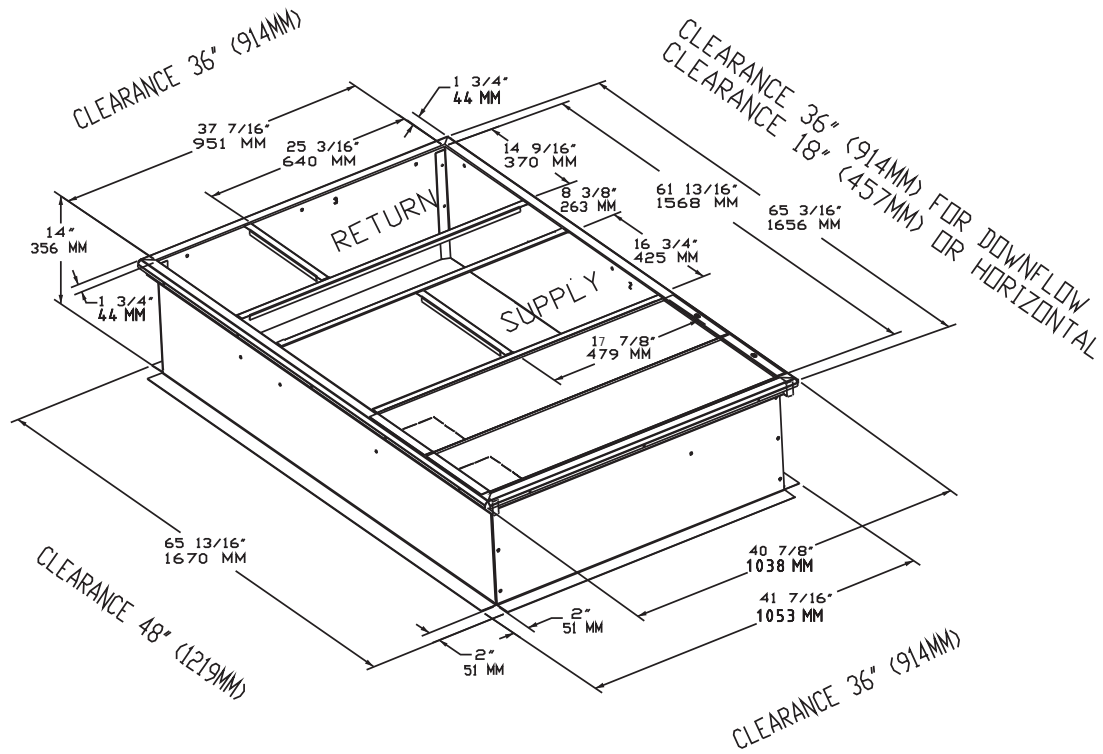

**Figure 7. Cooling, gas/electric and heat pump—5 tons standard efficiency—downflow duct connections - field fabricated**

**Note:** All dimensions are in inches/millimeters.

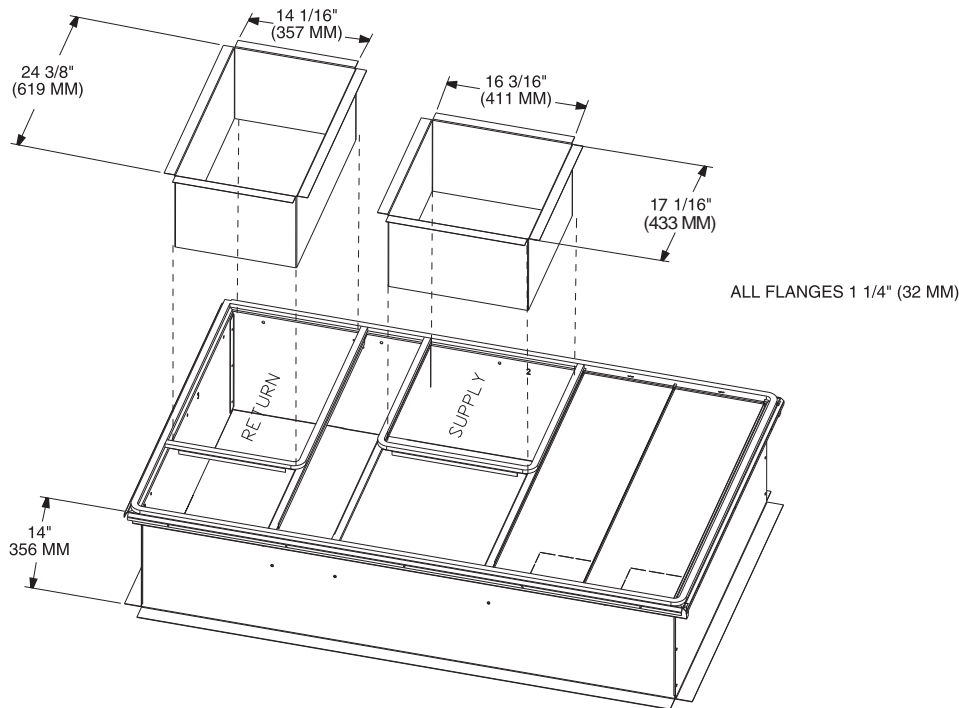

**Figure 8. Cooling, gas/electric and heat pump—5 tons standard efficiency, swing diameter for hinged door(s) option**

**Note:** All dimensions are in inches/millimeters.

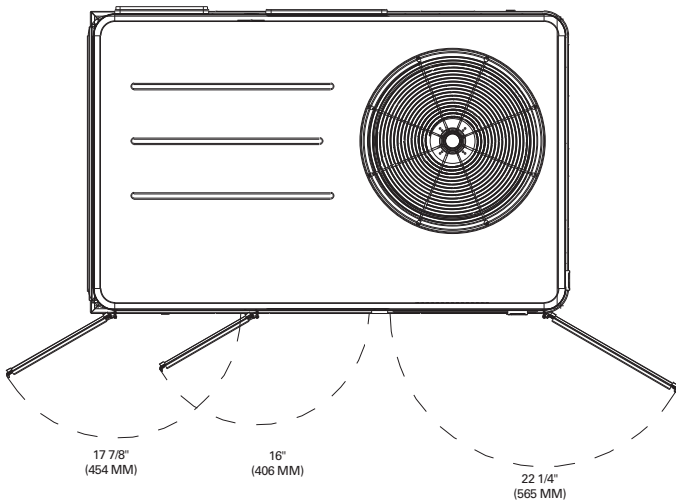

**Figure 9. Cooling, gas/electric and heat pump—5 tons standard efficiency, economizer & barometric relief damper hood**

**Note:** All dimensions are in inches/millimeters.

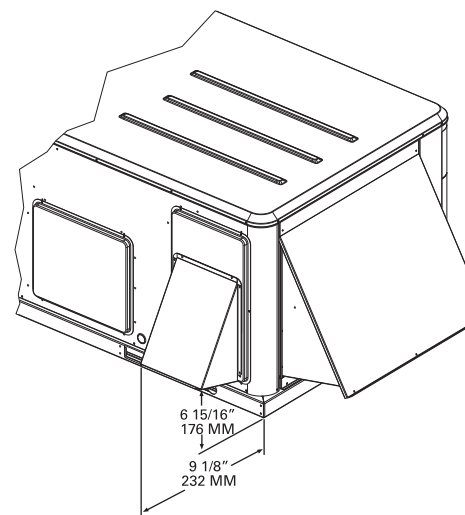

## Dimensional Data

**Figure 10. Cooling and gas/electric—6, 7½ tons standard efficiency**

**Note:** All dimensions are in inches/millimeters.

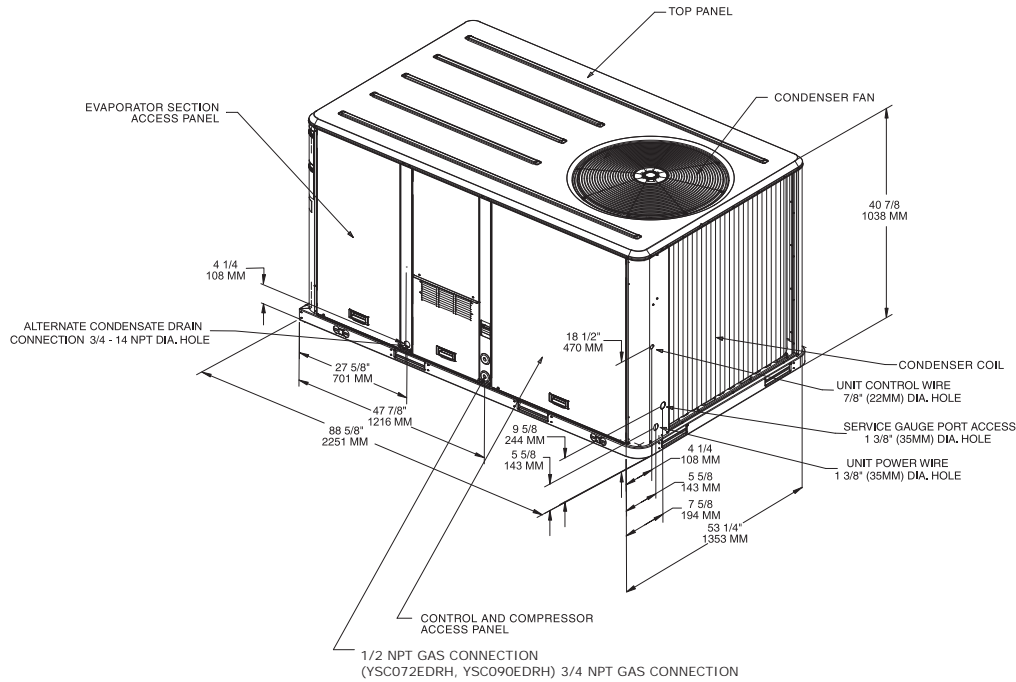

**Figure 11. Heat pump—6, 7½ tons standard efficiency**

**Note:** All dimensions are in inches/millimeters.

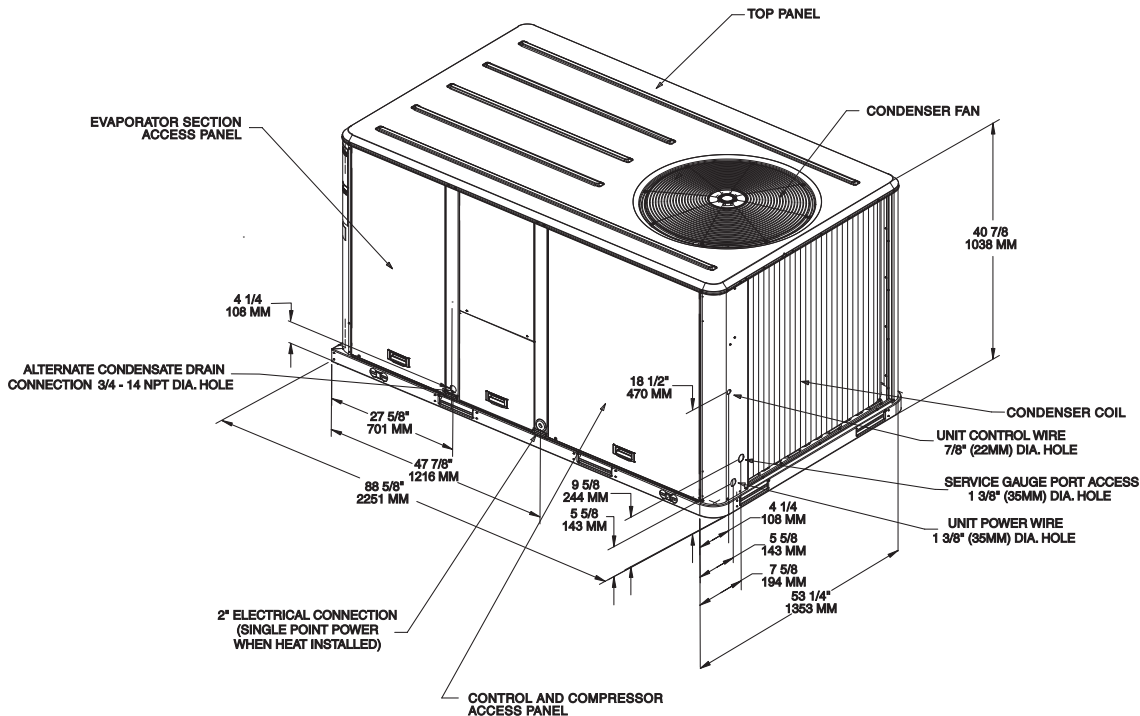



**Figure 12. Cooling, gas/electric and heat pump – 6, 7½ tons standard efficiency downflow airflow supply/return—through the base utilities**

**Note:** All dimensions are in inches/millimeters.

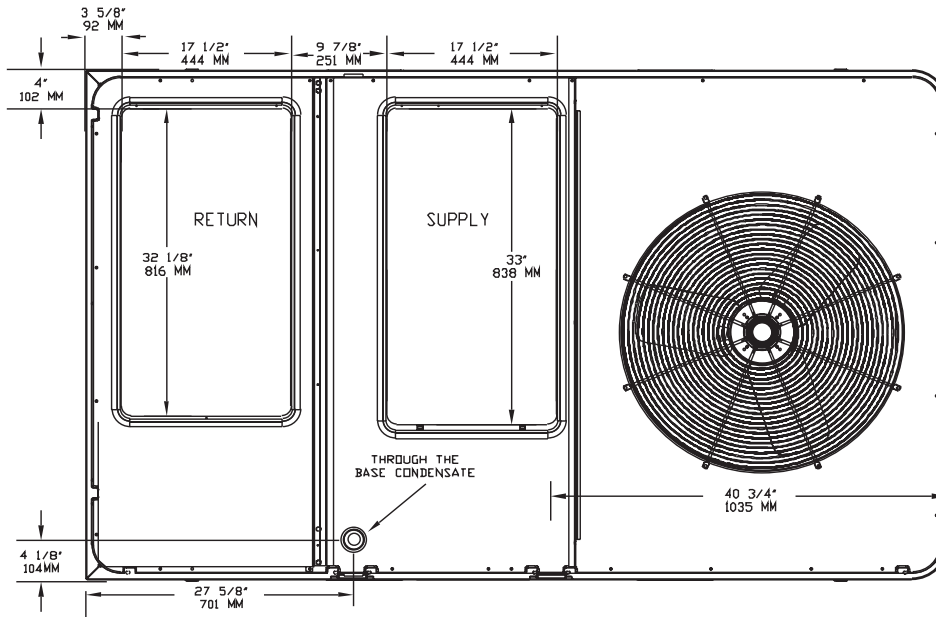

**Figure 13. Cooling, gas/electric and heat pumps—6, 7½ tons standard efficiency—horizontal airflow supply and return**

**Note:** All dimensions are in inches/millimeters.

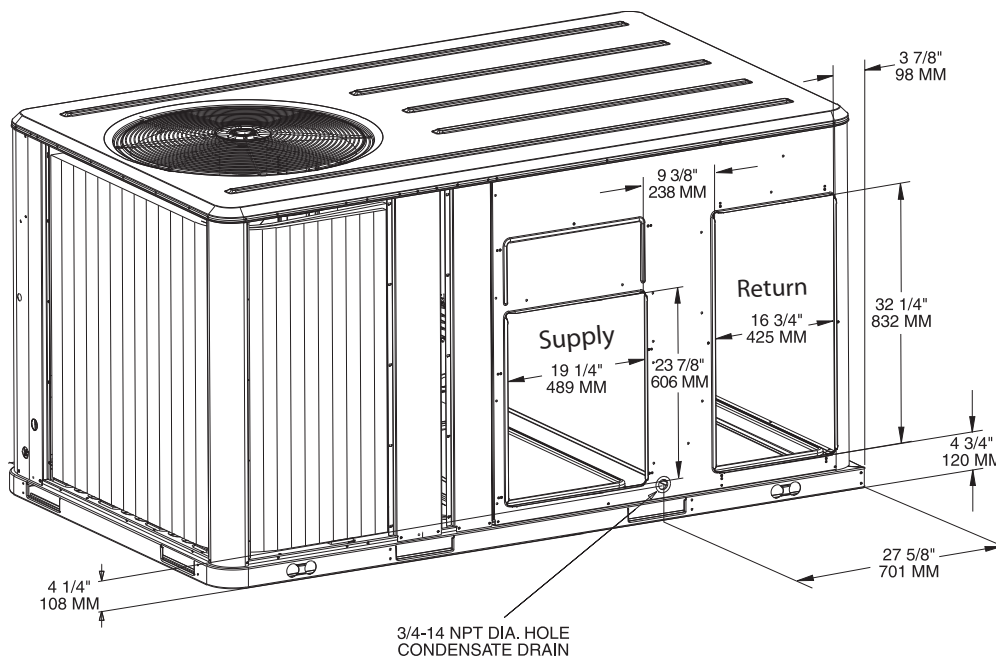

## Dimensional Data

**Figure 14. Cooling, gas/electric and heat pump—6, 7½ tons standard efficiency—unit clearance and roof opening**

Note: All dimensions are in inches/millimeters.

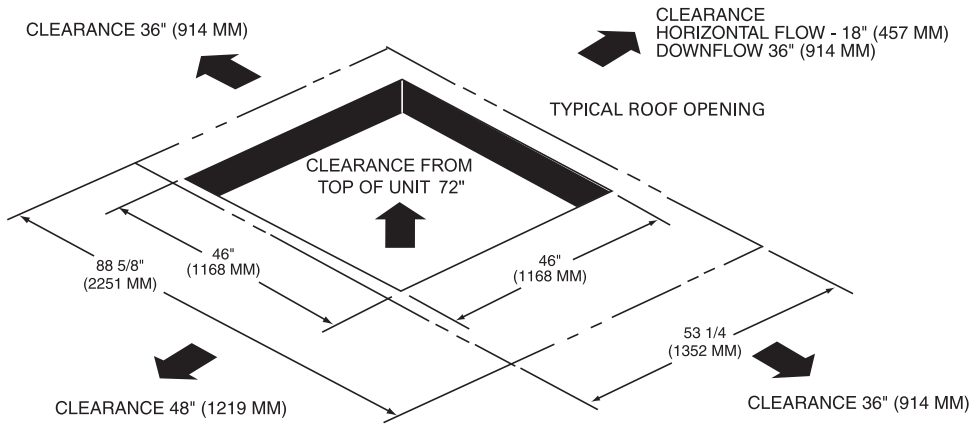

**Figure 15. Cooling, gas/electric and heat pump—6, 7½ tons standard efficiency—roof curb**

Note: All dimensions are in inches/millimeters.

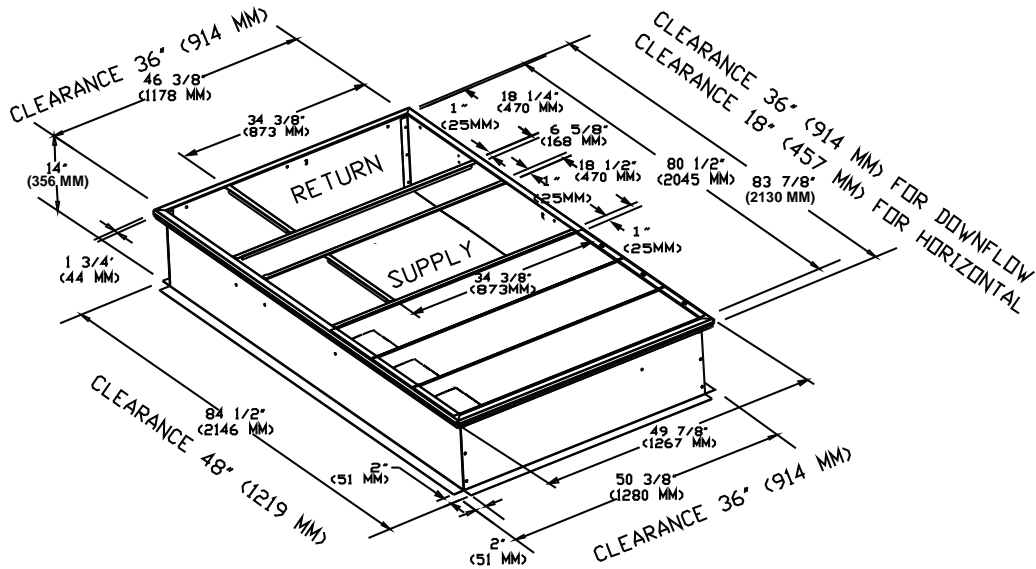

**Figure 16. Cooling, gas/electric and heat pumps—6, 7½ tons standard efficiency—downflow duct connections field fabricated**

**Note:** All dimensions are in inches/millimeters.

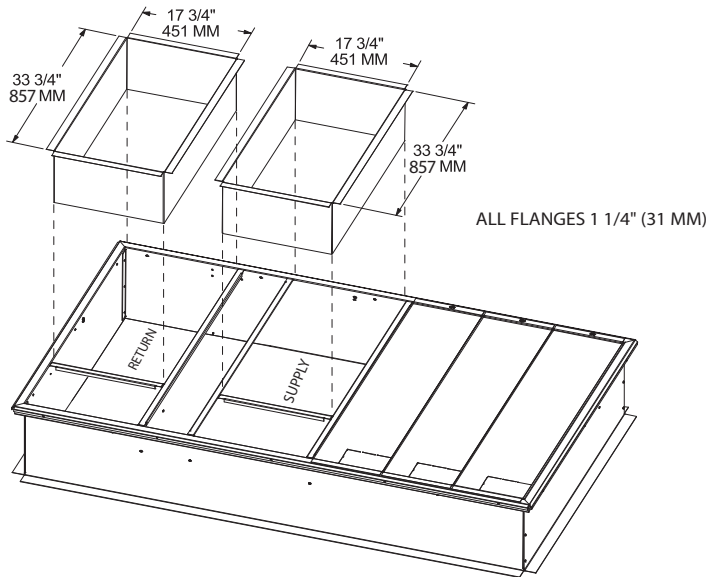

**Figure 17. Cooling, gas/electric and heat pump—6, 7½ tons standard efficiency—swing diameter for hinged door(s) option**

**Note:** All dimensions are in inches/millimeters.

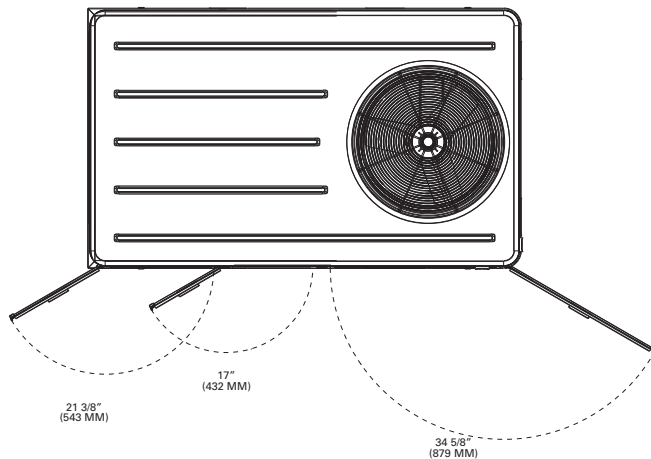

**Figure 18. Cooling, gas/electric and heat pump—6, 7½ tons standard efficiency—economizer, manual or motorized fresh air damper**

**Note:** All dimensions are in inches/millimeters.

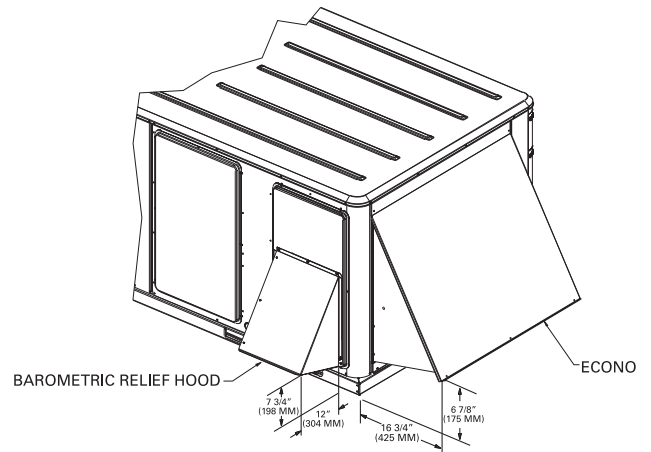

## Dimensional Data

**Figure 19. Cooling and gas/electric—8½, 10 tons standard efficiency**

**Note:** All dimensions are in inches/millimeters.

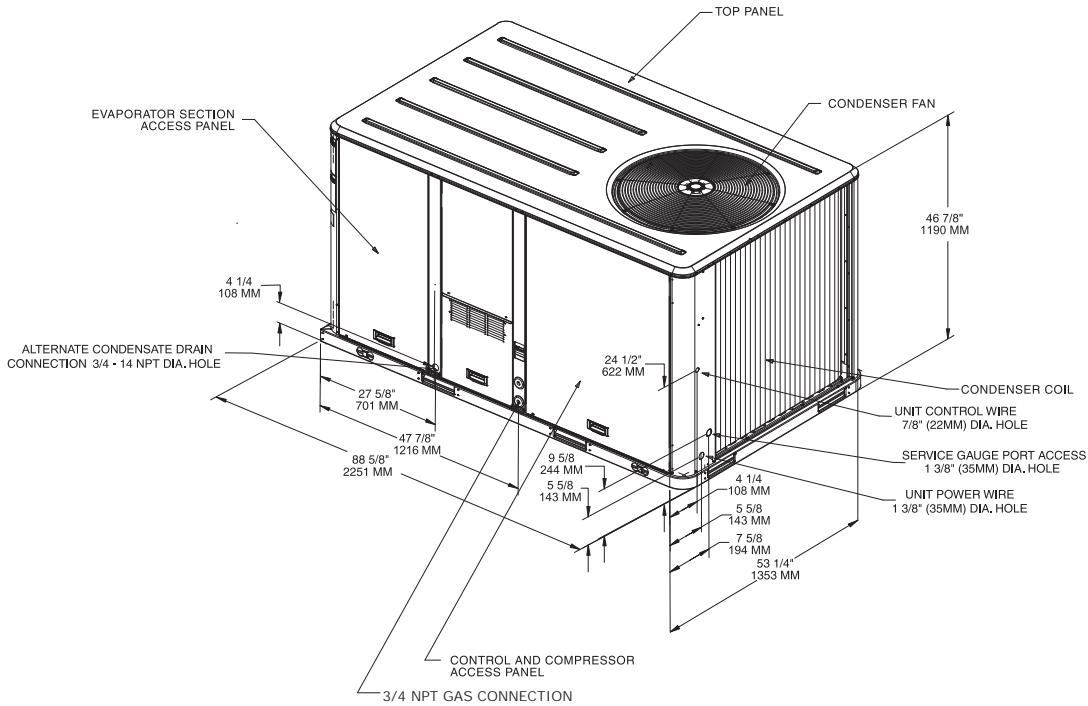

**Figure 20. Heat pump—10 tons standard efficiency**

**Note:** All dimensions are in inches/millimeters.

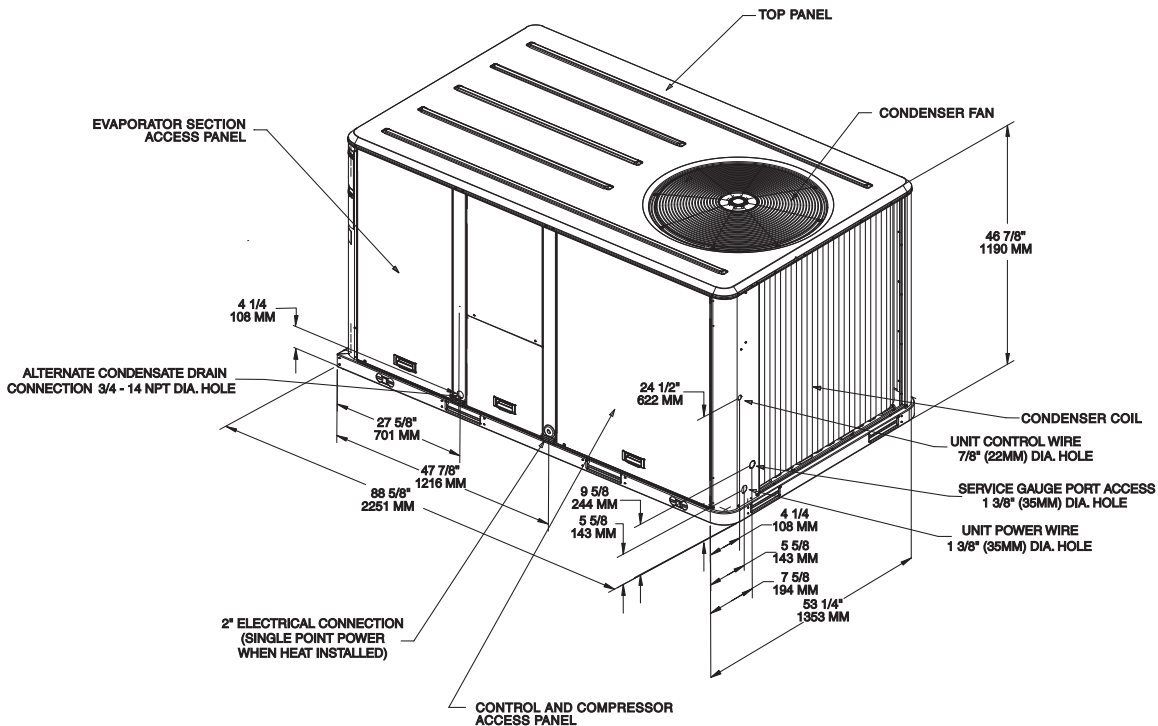

**Figure 21. Cooling and gas/electric—8½, 10 tons standard efficiency; Heat pump—10 tons—downflow airflow supply/return through the base utilities**

**Note:** All dimensions are in inches/millimeters.

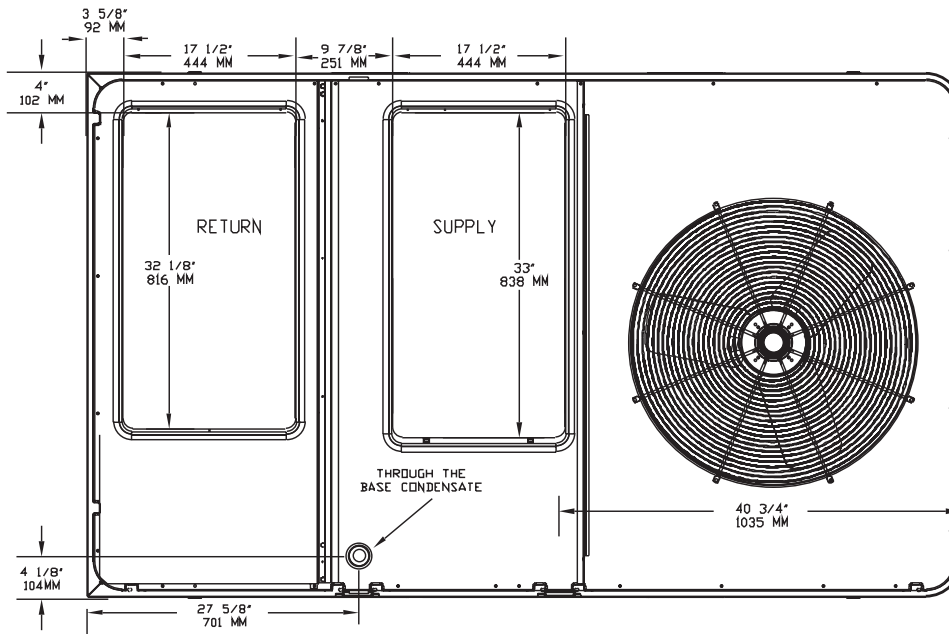

**Figure 22. Cooling and gas/electric—8½, 10 tons standard efficiency; Heat pump—10 ton—horizontal airflow supply and return**

**Note:** All dimensions are in inches/millimeters.

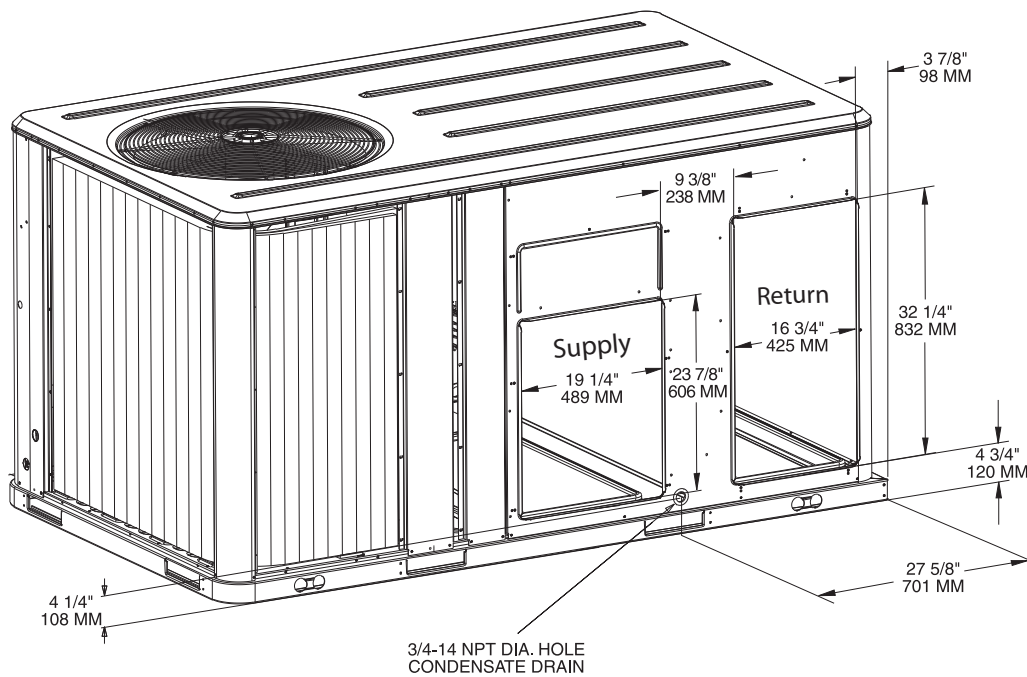

## Dimensional Data

**Figure 23. Cooling and gas/electric—8½, 10 tons standard efficiency; Heat pump—10 ton—unit clearance and roof opening**

**Note:** All dimensions are in inches/millimeters.

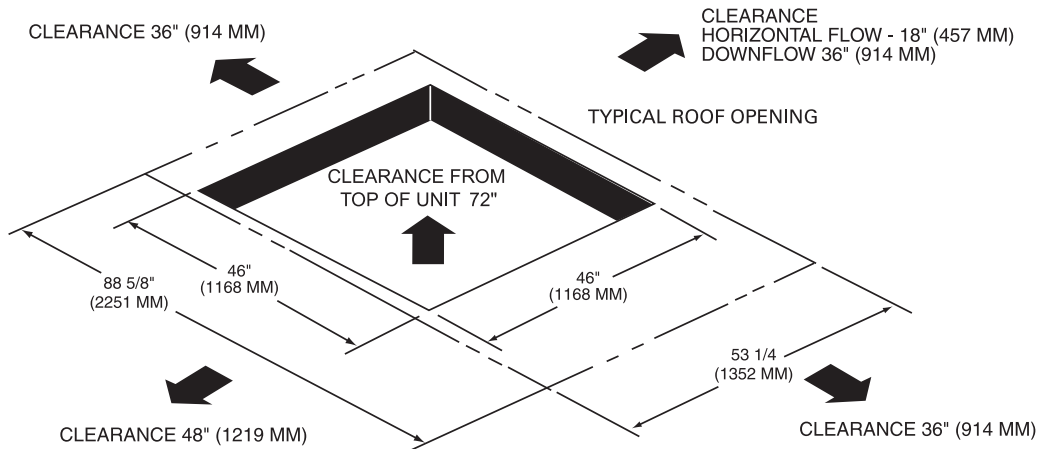

**Figure 24. Cooling and gas/electric—8½, 10 tons standard efficiency; Heat pump—10 ton—roof curb**

**Note:** All dimensions are in inches/millimeters.

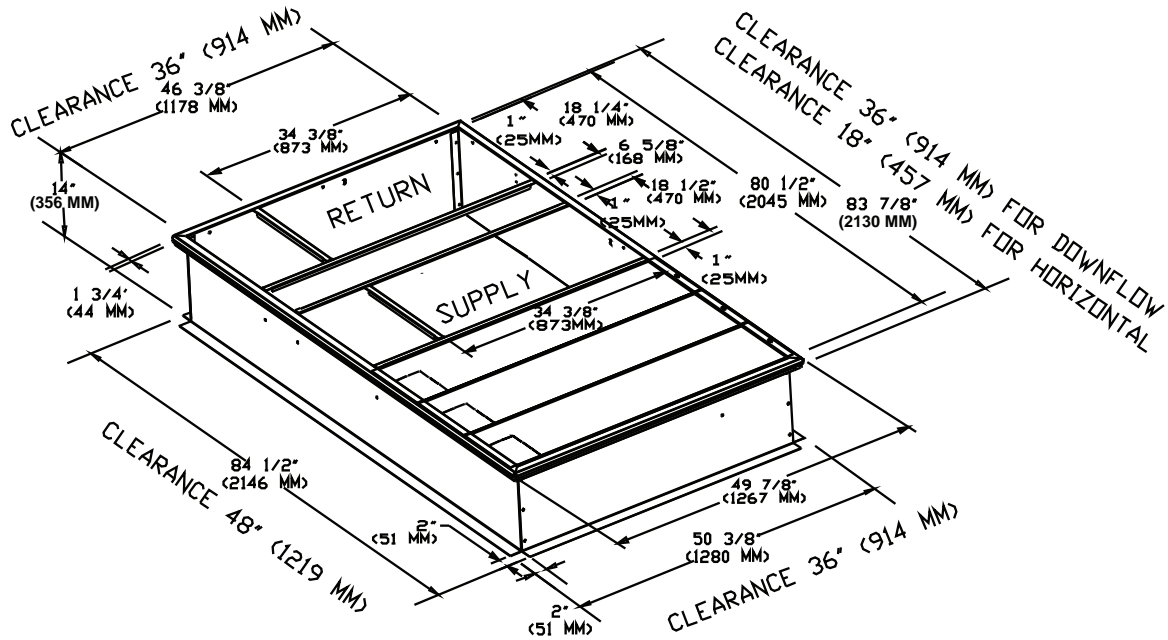

**Figure 25. Cooling and gas/electric—8½, 10 tons standard efficiency; Heat pump—10 ton downflow—duct connections field fabricated**

**Note:** All dimensions are in inches/millimeters.

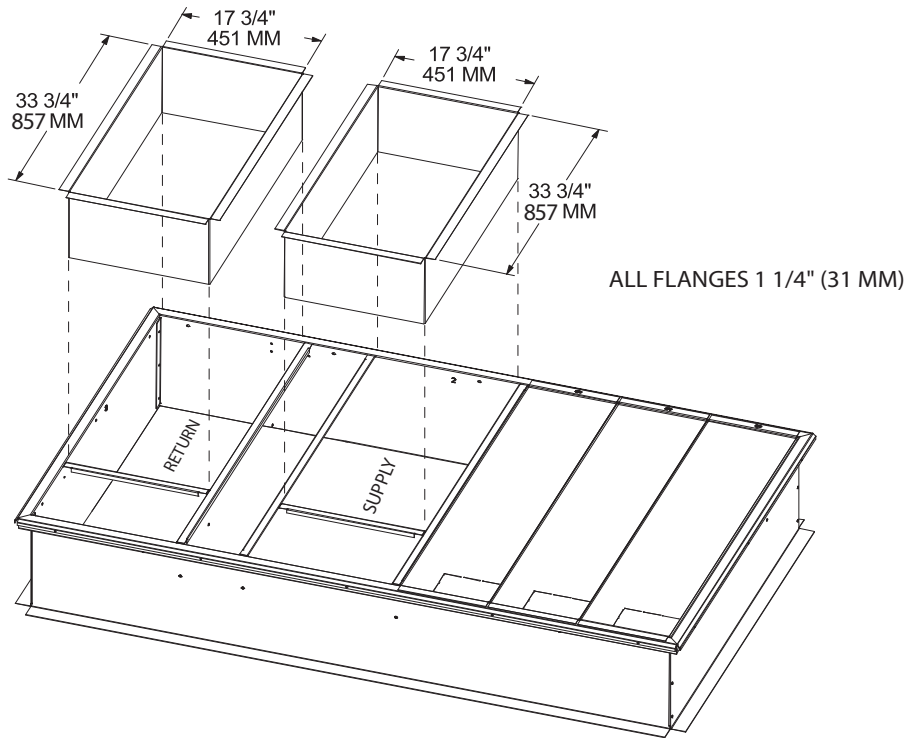

**Figure 26. Cooling and gas/electric—8½, 10 tons standard efficiency; Heat pump—10 ton—swing diameter for hinged door(s) option**

**Note:** All dimensions are in inches/millimeters.

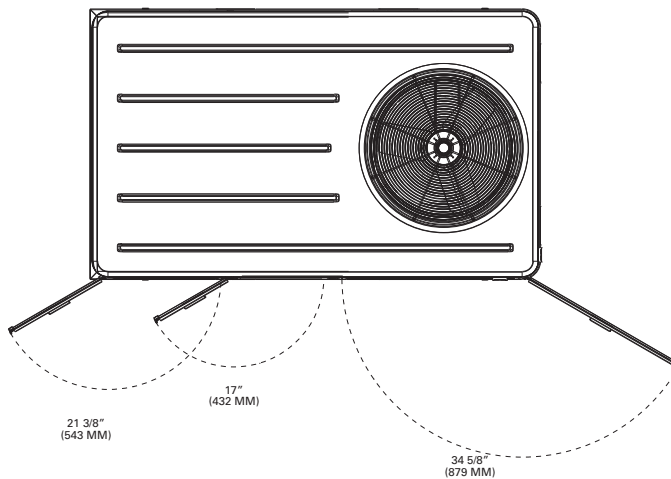

**Figure 27. Cooling and gas/electric—8½, 10 tons standard efficiency; Heat pump—10 ton economizer, manual or motorized fresh air damper**

**Note:** All dimensions are in inches/millimeters.

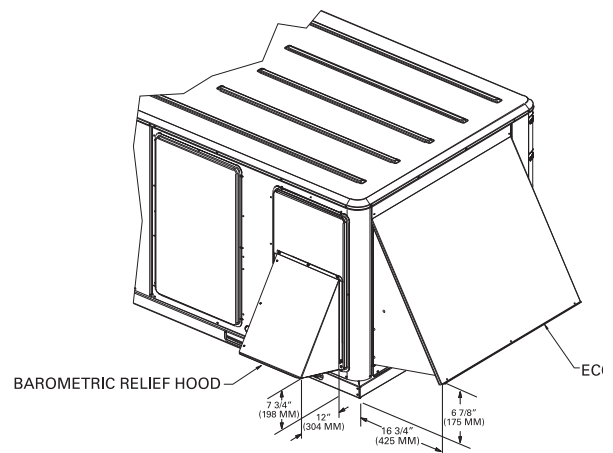

# Weights

**Table 1. Maximum unit & corner weights (kg) and center of gravity dimensions (mm)—cooling models (SI)**

Tons	Unit Model No.	Maximum Model Weights <sup>(a)</sup> (kg)		Corner Weights <sup>(b)</sup> (kg)				Center of Gravity (mm)	
		Shipping	Net	A	B	C	D	Length	Width
5	TSC060ED	288	240	76	58	49	57	1006	597
6	TSC072ED	415	355	127	87	65	76	963	535
7½	TSC090ED	434	374	150	82	65	76	889	512
8½	TSC102ED	478	415	139	117	71	89	1015	520
10	TSC120ED	489	426	148	111	79	88	1003	532

(a) Weights are approximate.

(b) Corner weights are given for information only. All models must be supported continuously by a curb or equivalent frame support.

**Table 2. Maximum unit & corner weights (lbs) and center of gravity dimensions (in)—cooling models (IP)**

Tons	Unit Model No.	Maximum Model Weights <sup>(a)</sup> (lbs)		Corner Weights <sup>(b)</sup> (lbs)				Center of Gravity (in)	
		Shipping	Net	A	B	C	D	Length	Width
5	TSC060ED	633	528	167	128	108	125	40	23
6	TSC072ED	915	783	281	192	143	167	38	21
7½	TSC090ED	956	824	331	181	144	168	35	20
8½	TSC102ED	1054	916	307	257	156	196	40	20
10	TSC120ED	1078	940	326	244	175	195	40	21

(a) Weights are approximate.

(b) Corner weights are given for information only. All models must be supported continuously by a curb or equivalent frame support.

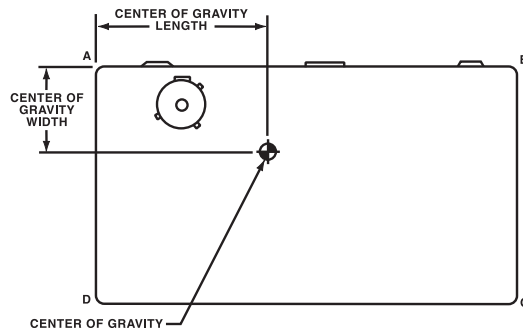

**Table 3. Maximum unit & corner weights (kg) and center of gravity dimensions (mm)—gas/electric models (SI)**

Tons	Unit Model No.	Maximum Model Weights <sup>(a)</sup> (kg)		Corner Weights <sup>(b)</sup> (kg)				Center of Gravity (mm)	
		Shipping	Net	A	B	C	D	Length	Width
5	YSC060ED	312	264	82	65	55	62	1025	600
6	YSC072ED	443	383	134	95	72	82	980	542
7½	YSC090ED	461	401	157	90	72	82	909	519
8½	YSC102ED	510	447	147	126	79	95	1031	526
10	YSC120ED	522	459	156	120	88	95	1020	538

(a) Weights are approximate.

(b) Corner weights are given for information only. All models must be supported continuously by a curb or equivalent frame support.



**Table 4. Maximum unit & corner weights (lbs) and center of gravity dimensions (in) – gas/electric models (IP)**

Tons	Unit Model No.	Maximum Model Weights <sup>(a)</sup> (lbs)		Corner Weights <sup>(b)</sup> (lbs)				Center of Gravity (in)	
		Shipping	Net	A	B	C	D	Length	Width
5	YSC060ED	689	584	181	144	122	137	40	24
6	YSC072ED	975	843	296	209	158	180	39	21
7½	YSC090ED	1016	884	346	198	159	181	36	20
8½	YSC102ED	1125	987	325	278	174	210	41	21
10	YSC120ED	1149	1011	344	265	193	209	40	21

(a) Weights are approximate.

(b) Corner weights are given for information only. All models must be supported continuously by a curb or equivalent frame support.

**Table 5. Maximum unit & corner weights (kg) and center of gravity dimensions (mm) – gas/electric models (SI)**

Tons	Unit Model No.	Maximum Model Weights <sup>(a)</sup> (kg)		Corner Weights <sup>(b)</sup> (kg)				Center of Gravity (mm)	
		Shipping	Net	A	B	C	D	Length	Width
5	WSC060ED	304	256	77	64	44	71	945	609
6	WSC072ED	397	337	114	84	66	73	1003	557
7½	WSC090ED	439	379	128	89	68	94	933	578
10	WSC120ED	511	448	151	116	78	103	977	547

(a) Weights are approximate.

(b) Corner weights are given for information only. All models must be supported continuously by a curb or equivalent frame support.

**Table 6. Maximum unit & corner weights (lbs) and center of gravity dimensions (in) – gas/electric models (IP)**

Tons	Unit Model No.	Maximum Model Weights <sup>(a)</sup> (lbs)		Corner Weights <sup>(b)</sup> (lbs)				Center of Gravity (in)	
		Shipping	Net	A	B	C	D	Length	Width
5	WSC060ED	667	562	169	140	96	157	37	24
6	WSC072ED	873	741	251	185	145	160	39	22
7½	WSC090ED	968	836	282	196	150	207	37	23
10	WSC120ED	1124	986	332	255	173	226	38	22

(a) Weights are approximate.

(b) Corner weights are given for information only. All models must be supported continuously by a curb or equivalent frame support.

**Table 7. Accessory net weights (kg) <sup>(a)</sup> (SI)**

Accessory <sup>(c)</sup>	Net Weights <sup>(b)</sup>	
	T/YSC060ED	T/YSC072-120ED
Economizer	12	16
Barometric Relief	3	5
Motorized Outside Air Damper	9	14
Manual Outside Air Damper	7	12
Roof Curb	28	35
Oversized Motor	—	4
Coil Guards	5	9
Hinged Doors	5	5

(a) Weights for options not listed are <3 kg.

(b) Net weight should be added to unit weight when ordering factory-installed accessories.

(c) Some accessories not available on all units.

## Weights

**Table 8. Accessory net weights<sup>(a)</sup> (IP)**

Accessory <sup>(c)</sup>	Net Weights (lbs) <sup>(b)</sup>	
	T/YSC060ED	T/YSC072-120ED
Economizer	26	36
Barometric Relief	7	10
Motorized Outside Air Damper	20	30
Manual Outside Air Damper	16	26
Roof Curb	61	78
Oversized Motor	—	8
Coil Guards	12	20
Hinged Doors	10	12

(a) Weights for options not listed are <5 lbs.

(b) Net weight should be added to unit weight when ordering factory-installed accessories.

(c) Some accessories not available on all units.

**Table 9. Accessory net weights (kg) <sup>(a)</sup> (SI)**

Accessory <sup>(c)</sup>	Net Weights <sup>(b)</sup>	
	WSC060ED	WSC072-120ED
Economizer	12	16
Barometric Relief	3	5
Motorized Outside Air Damper	9	14
Manual Outside Air Damper	7	12
Roof Curb	28	35
Oversized Motor	—	4
Coil Guards	5	9
Hinged Doors	5	5

(a) Weights for options not listed are <3 kg.

(b) Net weight should be added to unit weight when ordering factory-installed accessories.

(c) Some accessories not available on all units.

**Table 10. Accessory net weights<sup>(a)</sup> (IP)**

Accessory <sup>(c)</sup>	Net Weights (lbs) <sup>(b)</sup>	
	WSC060ED	WSC072-120ED
Economizer	26	36
Barometric Relief	7	10
Motorized Outside Air Damper	20	30
Manual Outside Air Damper	16	26
Roof Curb	61	78
Oversized Motor	—	8
Coil Guards	12	20
Hinged Doors	10	12

(a) Weights for options not listed are <5 lbs.

(b) Net weight should be added to unit weight when ordering factory-installed accessories.

(c) Some accessories not available on all units.



# Mechanical Specifications

## General

The units shall be convertible airflow. The operating range shall be between 52°C and -18°C (125°F and 0°F) in cooling as standard from the factory. All units shall be factory assembled, internally wired, fully charged with R-410A, and 100 percent run tested to check cooling operation, fan and blower rotation, and control sequence before leaving the factory. Wiring internal to the unit shall be colored and numbered for simplified identification.

## Casing

Unit casing shall be constructed of zinc coated, heavy gauge, galvanized steel. Exterior surfaces shall be cleaned, phosphatized, and finished with a weather-resistant baked enamel finish. Unit's surface shall be tested 500 hours in a salt spray test in compliance with ASTM B117. Cabinet construction shall allow for all maintenance on one side of the unit. Service panels shall have lifting handles and be removed and reinstalled by removing two fasteners while providing a water and air tight seal. All exposed vertical panels and top covers in the indoor air section shall be insulated with a cleanable foil-faced, fire-retardant permanent, odorless glass fiber material. The base of the unit shall be insulated with 3.2 mm (1/8 inch), foil-faced, closed-cell insulation. All insulation edges shall be either captured or sealed. The unit's base pan shall have no penetrations within the perimeter of the curb other than the raised 29 mm (1 1/8 inch) high downflow supply/return openings to provide an added water integrity precaution, if the condensate drain backs up. The base of the unit shall have provisions for forklift and crane lifting, with forklift capabilities on three sides of the unit.

## Compressors

All units shall have direct-drive, hermetic, scroll type compressors with centrifugal type oil pumps. Motor shall be suction gas-cooled and shall have a voltage utilization range of plus or minus 10 percent of unit nameplate voltage. Internal overloads shall be provided with the scroll compressors.

Crankcase heaters shall be included on all units.

Dual compressors are outstanding for humidity control, light load cooling conditions and system back-up applications. Dual compressors are available on 8½ to 10 ton models.

## Controls

Unit shall be completely factory-wired with necessary controls and contactor pressure lugs or terminal block for power wiring. Unit shall provide an external location for mounting a fused disconnect device.

ReliaTel™ controls are standard.

Microprocessor controls provide for all 24V control functions. The resident control algorithms shall make all heating, cooling, and/or ventilating decisions in response to electronic signals from sensors measuring indoor and outdoor temperatures. The control algorithm maintains accurate temperature control, minimizes drift from set point, and provides better building comfort. A centralized microprocessor shall provide anti-short cycle timing and time delay between compressors to provide a higher level of machine protection.

Units shall have single point entry as standard.

## Evaporator and Condenser Coils

Internally finned, 8 mm (5/16 inch) copper tubes mechanically bonded to a configured aluminum plate fin shall be standard. Coils shall be leak tested at the factory to ensure the pressure integrity. The evaporator coil and condenser coil shall be leak tested to 3206 kPa (465 psig). The assembled unit is leak tested to 4137 kPa (600 psig). The condenser coil shall have a patent pending 1+1+1 hybrid coil designed with slight gaps for ease of cleaning. A removable, reversible, double-sloped, non-corrosive, condensate drain pan with through the base condensate drain is standard.

## Mechanical Specifications

---

### Filters

Throwaway filters shall be standard on all units. Optional 2-inch MERV 8 and MERV 13 filters shall also be available.

### Gas Heating Section

The heating section shall have a progressive tubular heat exchanger design using stainless steel burners and corrosion resistant steel throughout. An induced draft combustion blower shall be used to pull the combustion products through the firing tubes. The heater shall use a direct spark ignition (DSI) system. On initial call for heat, the combustion blower shall purge the heat exchanger for 20 seconds before ignition. After three unsuccessful ignition attempts, the entire heating system shall be locked out until manually reset at the thermostat/zone sensor. Units shall be suitable for use with natural gas or propane (field-installed kit).

### High Pressure Control

All units include High Pressure Cutout as standard.

### Indoor Fan

All units shall have belt drive motors with an adjustable idler-arm assembly for quick-adjustment to fan belts and motor sheaves. All motors shall be thermally protected. Oversized motors shall be available for high static operations. All indoor fan motors meet the U.S. Energy Policy Act of 1992 (EPACT).

### Outdoor Fans

The outdoor fan shall be direct-drive, statically balanced, draw-through in the vertical discharge position. The fan motor shall be permanently lubricated and shall have built-in thermal overload protection.

### Phase Monitoring Protection

Precedent™ units with 3-phase power are equipped with phase monitoring protection as standard. These devices protect motors and compressors against problems caused by phase loss, phase imbalance and phase reversal indication.

### Refrigerant Circuits

Each refrigerant circuit offer thermal expansion valve as standard. Service pressure ports, and refrigerant line filter driers are factory-installed as standard. An area shall be provided for replacement suction line driers.

### Unit Top

The top cover shall be one piece construction or where seams exist, it shall be outside the indoor air-conditioned section. The ribbed top adds extra strength and prevents water from pooling on unit top.

## Factory-Installed Options

### Black Epoxy Pre-Coated Coils

The black epoxy coils have a thermoset vinyl coating that is bonded to the aluminum fin stock prior to the fin-stamping process. The pre-coated coils are an economical option for protection in mildly corrosive environments.

### CompleteCoat™ Coils

The cathodic epoxy type electrodisposition coating is formulated for high edge build to plate fin and tube heat exchangers. The coating is selected to provide excellent resistance and durability to corrosive effects of alkalies, acids, alcohols, petroleum, seawater, salt air and corrosive

environments. This option is available for the plate fin-tube condenser coil and the microchannel type condenser coil.

### **Condensate Overflow Switch**

This option shall shut the unit down in the event that a clogged condensate drain line prevents proper condensate removal from the unit.

### **Frostat™**

In low ambient temperature and/or low airflow operating conditions, the evaporator coils may accumulate ice during cooling mode operation. ReliaTel™ monitors operating conditions and modifies operation to prevent ice formation. The Frostat may be utilized as an additional safety device to prevent frost accumulation and/or damage to the evaporator coils. The Frostat shuts off compressors when evaporator coil temperature falls below 10°F and will allow compressor operation when coil temperature rises above 50°F.

### **Heat Exchanger**

The compact cabinet features a tubular heat exchanger in low and high heat capacities.

The heat exchanger is fabricated using stainless steel burners and corrosion-resistant aluminized steel tubes as standard on all models. It has an induced draft blower to pull the gas mixture through the burner tubes. The heater has a direct spark ignition system which doubles as a safety device to prove the flame.

### **Hinged Access Doors**

Sheet metal hinges are available on the Filter/Evaporator, Supply Fan/Heat, and the Compressor/Control Access Doors.

### **Stainless Steel Drain Pan**

This option provides excellent corrosion and oxidation resistance. Drain pan shall be reversible and constructed of 304 stainless steel.

### **Thermal Expansion Valve**

Thermal Expansion Valve is standard for all models.

### **Two-Inch Filters**

Two-inch MERV 8 and MERV 13 media filters shall be available on all models.

## **Factory-Installed or Field-Installed Options**

### **Clogged Filter/Fan Failure Switch**

A dedicated differential pressure switch is available to achieve active fan failure indication and/or clogged filter indication. These indications will be registered with either a zone sensor with status indication lights or an Integrated Comfort™ System. This option is available for microprocessor controlled units.

### **Differential Pressure Switches**

These sensors allow individual fan failure and dirty filter indication for microprocessor controlled units. The fan failure switch will disable all unit functions and “flash” the Service LED on the zone sensor. The dirty filter switch will light the Service LED on the zone sensor and will allow continued unit operation.

### **Discharge Air Sensing**

This option provides true discharge air sensing in heating models. This sensor is a status indicator readable through Tracer™ or Tracker™. This option is available for microprocessor controlled units.

## Mechanical Specifications

---

### **Economizer**

This accessory shall be available with or without barometric relief. The assembly includes fully modulating 0-100 percent motor and dampers, minimum position setting, preset linkage, wiring harness with plug, spring return actuator and fixed dry bulb control. The barometric relief shall provide a pressure operated damper that shall be gravity closing and shall prohibit entrance of outside air during the equipment "off" cycle. Optional solid state or differential enthalpy control shall be available for either factory installation or field installation. The economizer arrives in the shipping position and shall be moved to the operating position by the installing contractor.

### **LonTalk® Communication Interface**

This option shall be provided to allow the unit to communicate as a Tracer™ LCI-R device or directly with generic LonTalk Network Building Automation System Controls.

### **Oversized Motors**

Factor- installed or field-installed oversized motors available for high static applications.

### **Reference or Comparative Enthalpy**

Reference Enthalpy is used to measure and communicate outdoor humidity. The unit receives and uses this information to provide improved comfort cooling while using the economizer.

Comparative Enthalpy measures and communicates humidity for both outdoor and return air conditions, and return air temperature. The unit receives and uses this information to maximize use of economizer cooling, and to provide maximum occupant comfort control. Reference or Comparative Enthalpy option shall be available when a factory-installed or field-installed downflow economizer is ordered. This option is available on all downflow models.

### **Tool-less Hail Guards**

Tool-less, hail protection guards are available for condenser coil protection.

### **Trane Communication Interface**

This option shall be provided to interface ReliaTel™ controlled units with the Trane Integrated Comfort™ systems.

## **Field-Installed Options**

### **CO<sub>2</sub> Sensor**

The CO<sub>2</sub> sensor shall have the ability to monitor the concentration (parts per million, ppm) of CO<sub>2</sub> (Carbon Dioxide) in the air. As the CO<sub>2</sub> concentration changes, the outside air damper modulates to meet the current ventilation needs of the zone.

### **High Static Drive**

The high static drive option shall allow the standard motor to operate with improved external static capabilities.

### **Manual Outside Air Damper**

This rain hood and screen shall provide up to 50 percent outside air.

### **Motorized Outside Air Damper**

Manually set outdoor air dampers shall provide up to 50 percent outside air. Once set, outdoor air dampers shall open to set position when indoor fan starts. The damper shall close to the full closed position when indoor fan shuts down.

### **Programmable Night Setback**

Auto or manual changeover with seven-day programming. Keyboard selection of Heat, Cool, Fan, Auto, or On. All programmable sensors have System On, Heat, Cool, Service LED/indicators as

standard. Night Setback Sensors have one (1) Occupied, one (1) Un-occupied, and one (1) Override program per day.

### **Remote Potentiometer**

The minimum position setting of the economizer shall be adjusted with this accessory.

### **Roof Curb**

The roof curb shall be designed to mate with the unit's downflow supply and return and provide support and a water tight installation when installed properly. The roof curb design shall allow field-fabricated rectangular supply/return ductwork to be connected directly to the curb. Curb shall be shipped knocked down for field assembly and shall include wood nailer strips.

### **Thermostat**

Two stage heating and cooling operation or one stage heating and cooling shall be available in either manual or automatic changeover. Automatic programmable electronic with night set back shall also be available.

### **Ventilation Override Accessory**

With the Ventilation Override Accessory installed, the unit can be set to transition up to 3 different pre-programmed sequences for Smoke Purge, Pressurization, and Exhaust. The transition occurs when a binary input on the RTOM is closed (shorted). This would typically be a hard wired relay output from a smoke detector or fire control panel. The ventilation override accessory shall be available as field installed.

### **Wireless Zone Sensor**

LCD display that provides heat, cool, auto or off. Includes two temperature setpoints and a lockable setting with °F or °C indicators.

### **Zone Sensor**

This control shall be provided to interface with the ReliaTel™ equipped units and shall be available in either manual, automatic programmable with night setback, with system malfunction lights, or remote sensor options.



Trane optimizes the performance of homes and buildings around the world. A business of Ingersoll Rand, the leader in creating and sustaining safe, comfortable and energy efficient environments, Trane offers a broad portfolio of advanced controls and HVAC systems, comprehensive building services, and parts. For more information, visit [www.Trane.com](http://www.Trane.com).

Trane has a policy of continuous product and product data improvement and reserves the right to change design and specifications without notice.

© 2015 Trane All rights reserved  
RT-PRC039C-EN 15 March 2015  
Supersedes RT-PRC039B-EN (10 August 2012)

We are committed to using environmentally  
conscious print practices that reduce waste.

